

Uniclass	EPIC
L3811:P43	C421:X421
CI/SfB	
(21-4)	Xh4



comar
ARCHITECTURAL ALUMINIUM SYSTEMS

comar5P.i

Window Cladding Interfaces

Aluminium window interfaces that allow a Comar window to be installed as a cladding panel.

The Parkside Group Ltd

Unit 5, The Willow Centre
17 Willow Lane, Mitcham
Surrey CR4 4NX

Tel: +44(0) 20 8685 9685

Fax: +44(0) 20 8646 5096

Email: sales@parksidegrp.co.uk

Web: www.comar-alu.co.uk

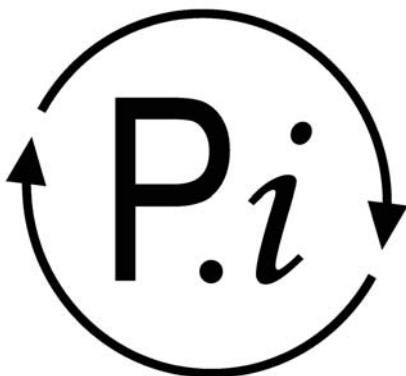

complementing architecture

design

Comar 5P.i Cladding Interfaces

Cladding the building envelope can provide a striking solution to a design brief. However installing opening vents into claddings can create issues with joint integrity. Traditionally, opening vents were installed with flashings and joint integrity relied on site applied sealant. The main disadvantage of this is long-term sealant degradation and lack of weather tightness of the façade.

Longevity of solution are the key words for Comar 5P.i Cladding Interfaces. The adaptor allows the specifier the design opportunity to incorporate windows into a façade without the need for additional flashings. The external frame of the windows incorporates the

cladding interface, which mimics the edge profile of the cladding system. This allows the window to be installed in exactly the same way as the panels.

Comar 5P.i Cladding Interfaces provide cost effectiveness: site labour is reduced, due to the seamless integration of the window system into the cladding.

As the adaptor utilises Comar P.i technology, low U-values and dual colour options are available. The adaptor fits all window combinations, so a variety of tilt and turn, horizontal and vertical pivot, top-swing, casement windows can be specified.

Integration

Kingspan

Kingspan's 70mm and 80mm Optimo cladding has slim sight lines which create a visually striking appearance. Available in cover widths of 900 or 1000mm, the system has a hidden joint detail which conceals fasteners from view.

Comar's Kingspan Panel Interfaces, allow window units to be prefabricated and "dropped" into the panel system facilitating the simple and quick construction that has become the standard with Kingspans systems. The advanced Optimo system also includes a broad range of project specific accessories for designers with simple integration for doors and windows.

Europanel

Europanel wall cladding is a flat composite wall panel specially designed for panel integrity, joint performance and ease of construction with the widest range of modules available. Europanel Premier system is a higher specification truly flat panel with a suite of integrated aluminum extruded trims and accessories including window integration, snap-on details, gasket joints and integrated louvres.

Other Options

Comar's Technical Department can produce profiles for other types of panels upon request. Please contact Comar's Marketing Department for further details.



perform



Comar 5P.i Window System

The Comar 5P.i is a 60mm polyamide system that provides exceptional thermal efficiency for applications where accurate U-value trade-offs are required. Comar 5P.i answers the demands of the latest building regulations by providing enhanced thermal performance, reducing heat loss and maintaining internal temperatures for longer. This directly impacts on the clients long term use of the building, reducing energy bills.

Comar 5P.i also provides a wealth of design possibilities with its dual colour option: the internal face and external faces of the profiles can be polyester powder coated or anodised in a multitude of colours and finishes. Comar 5P.i can incorporate through-frame or glazed-in ventilators from the Comar-Duco range. Comar 5P.i offers outstanding weather performance, exceeding the requirements of the very latest weather tightness tests: BS EN's 1026, 1027 & 12211.

Window Configurations

Comar 5P.i range includes window configurations, such as: casement, horizontal and vertical pivot, tilt and turn, top-swing reversible and sliding windows. Comar 5P.i integrates with all Comar systems to provide opening vents to window walling, curtain walling and ground floor treatment, as well as the ability to be coupled together to form ribbon windows.

Installation

These adaptor profiles have been designed to match the top and bottom of 'Kingspan' and 'Europanel' interlocking panel joints, enabling a window when fitted with these profiles, to be 'dropped' into the cladding system in the same way as a panel, eliminating the need for any separate parts or flashings, thus maintaining the continuity of cladding construction. Comar 5P.i Cladding Interfaces maintain the flush external appearance of the cladding.

Available Profiles

Profile	Kingspan Optimo		Europanel			
	70mm	80mm	5mm Panel Joints		12mm Panel Joints	
			85mm	126mm	85mm	126mm
Sill	•	•	•	•	•	•
Jamb	•	•	•	•	•	•
Head	•	•	•	•	•	•

europanel

Europanel Cladding Interfaces 126mm and 85mm Panels Typical Jamb Details

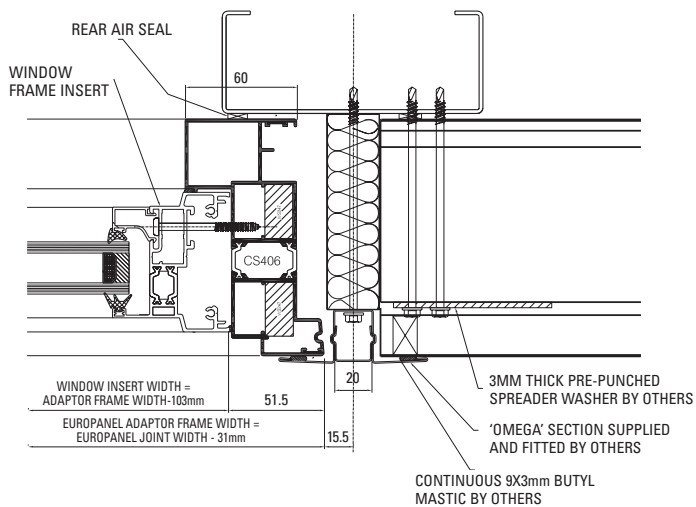

126mm thick Europanel jamb detail using Omega sections EPH-02A, 2B and 2C

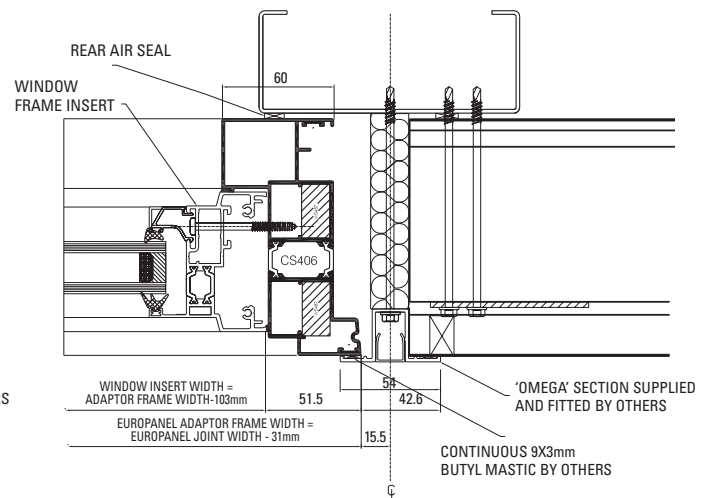

126mm thick Europanel jamb detail using Omega sections PSH-02A and PSH-02B

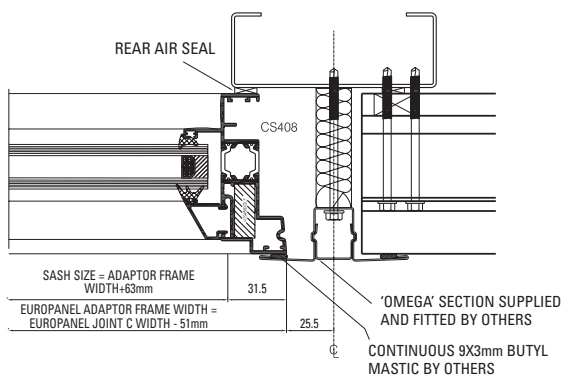

85mm thick Europanel jamb detail using Omega sections EPH-02A, 2B and 2C

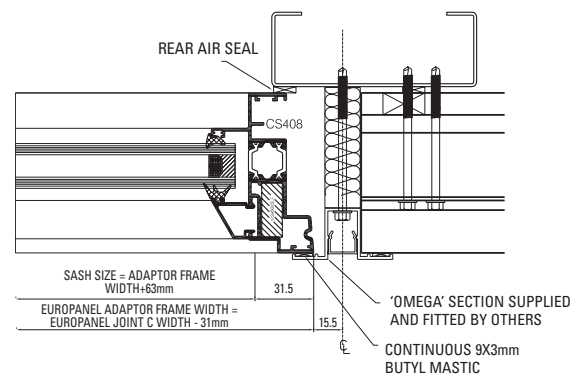

85mm thick Europanel jamb detail using Omega sections EPH-02A, 2B and 2C

europanel

Europanel Cladding Interfaces 126mm and 85mm Panels Typical Head Details

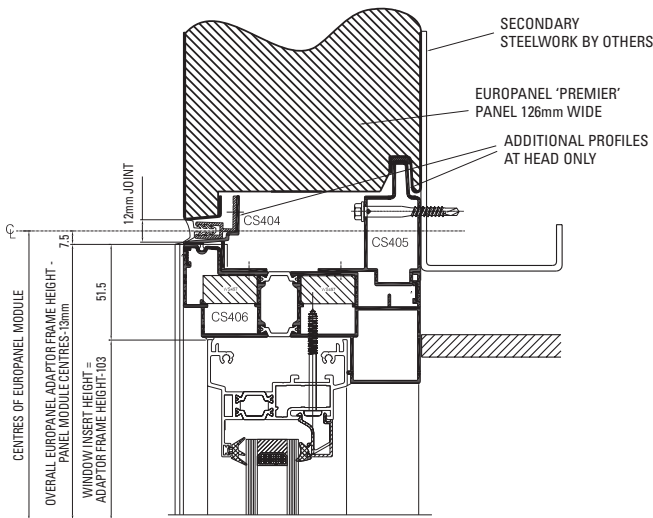

126mm Europanel head detail for 12mm jointing system

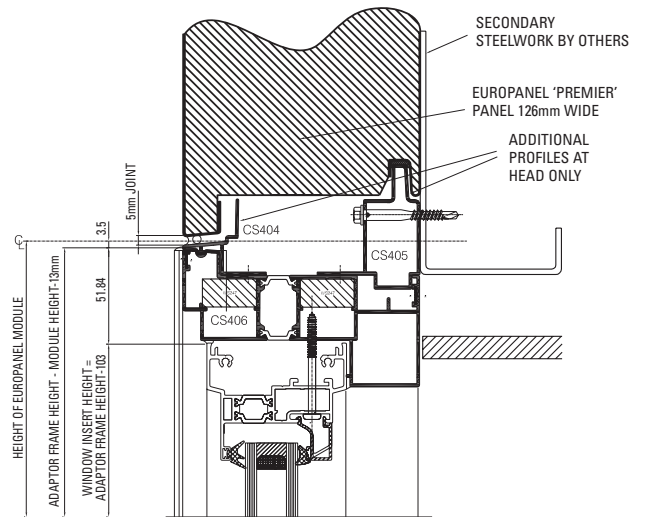

126mm Europanel head detail for 5mm jointing system

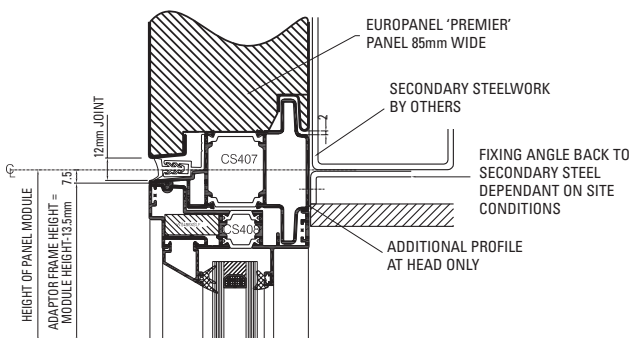

85mm Europanel head detail for 12mm jointing system

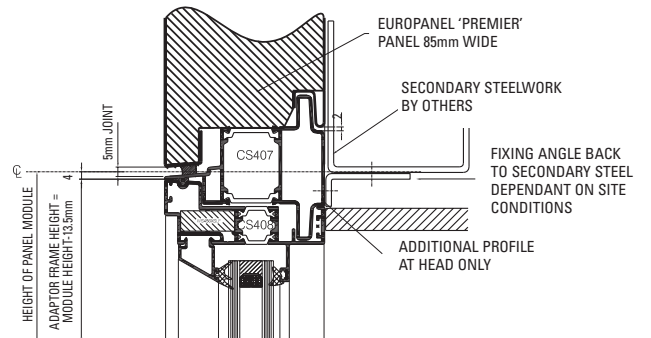

85mm Europanel head detail for 5mm jointing system

europanel

Europanel Cladding Interfaces 126mm and 85mm Panels Typical Sill Details

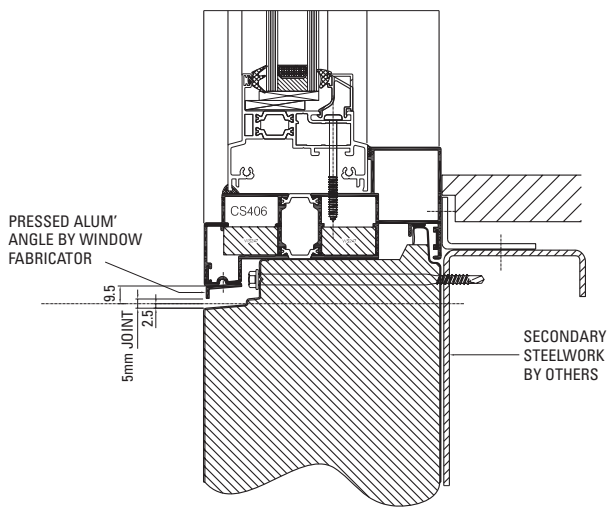

126mm Europanel sill detail for 5mm jointing system

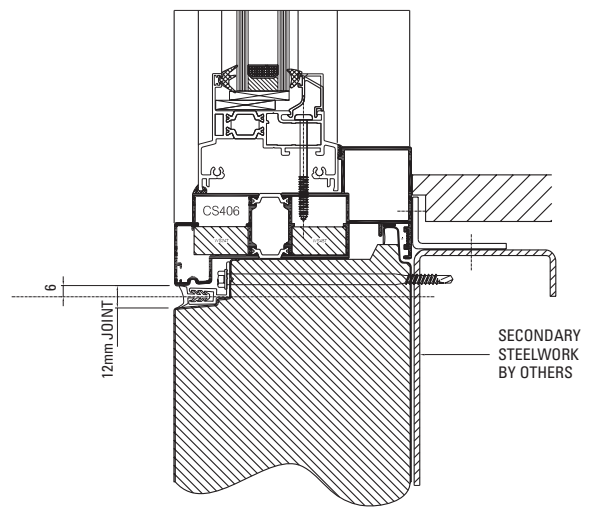

126mm Europanel sill detail for 12mm jointing system

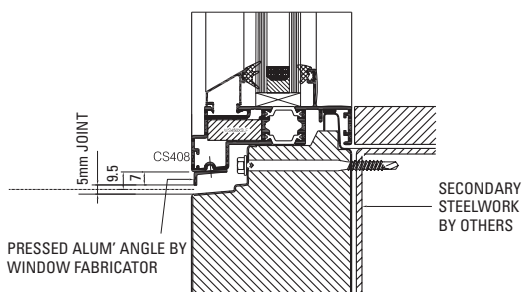

85mm Europanel sill detail for 5mm jointing system

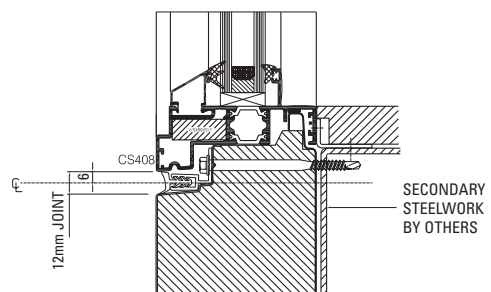

85mm Europanel sill detail for 12mm jointing system

kingspan

Kingspan Interfaces 80mm Panels Typical Details

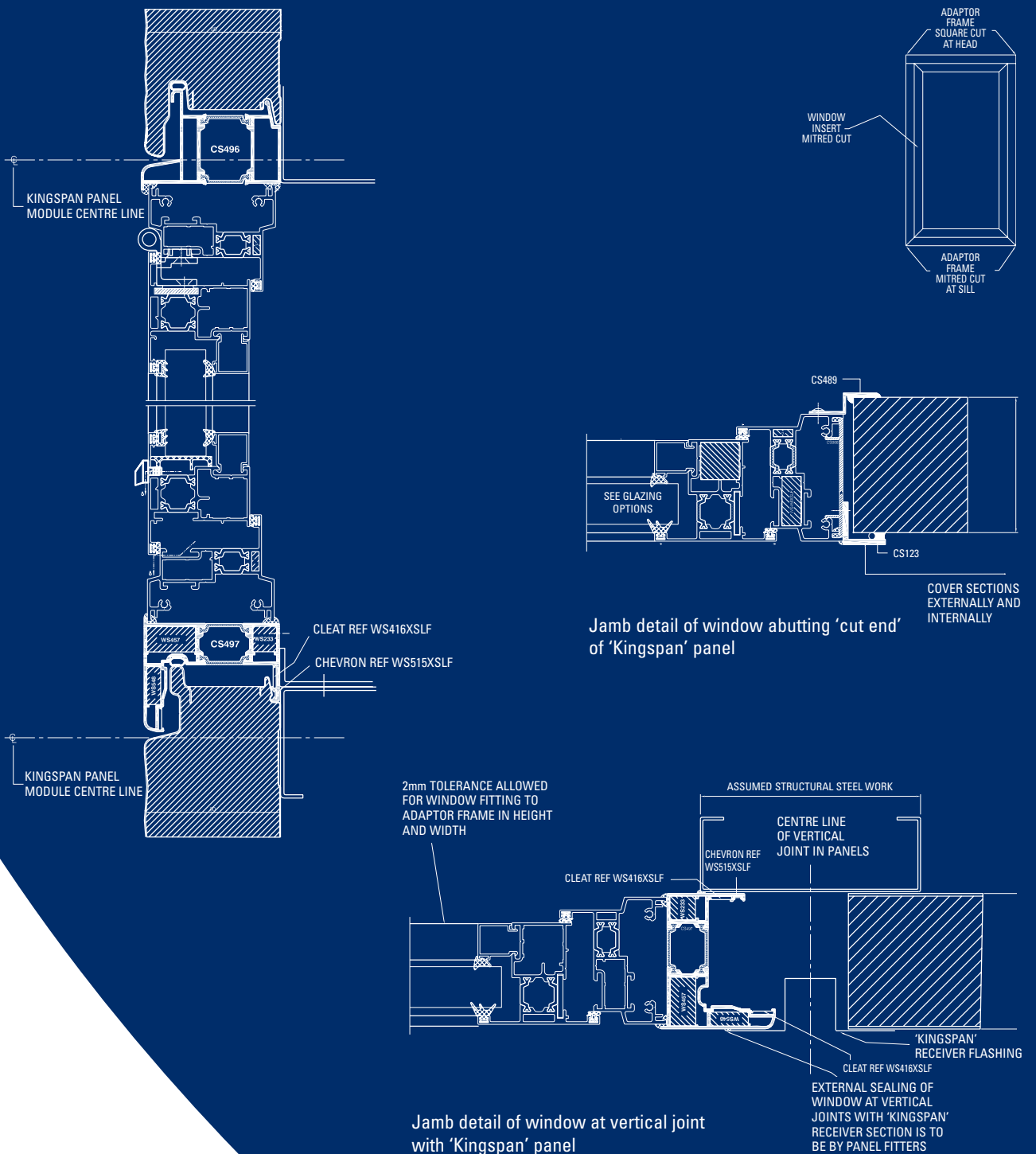

kingspan

Kingspan Cladding Interfaces 70mm Panels Typical Details

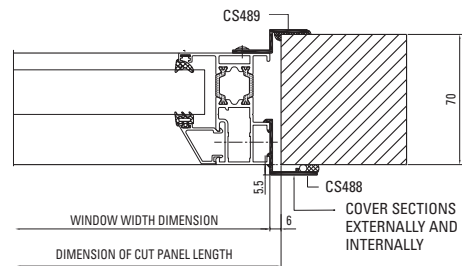
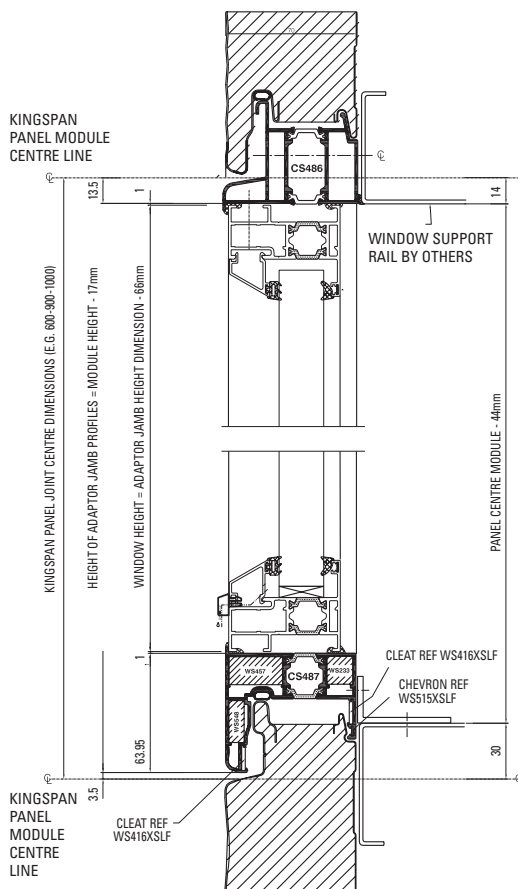

Jamb detail of window at vertical joint with 'Kingspan' panel

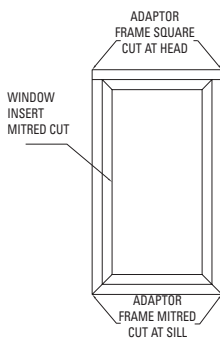
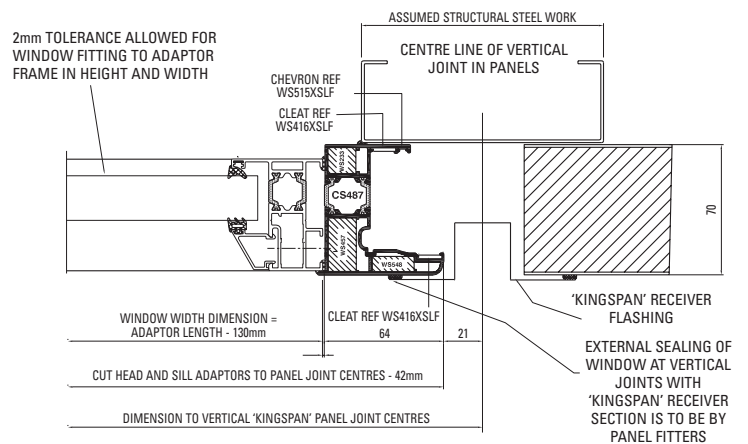

Technical Back-Up

An experienced Sales Team covers the UK while the Technical Department offers an unsurpassed design and installation advice service to designers, specifiers and fabricators; simply call: +44(0) 20 8685 9685

For More Information

To find out more about this or any other Comar Architectural Aluminium System, or to obtain your personal copies of the COMAR TECHNICAL MANUALS call: +44(0) 20 8685 9685 or fax on: +44(0) 20 8646 5096

