

Main Index

ETC Index	Index Page A01 Updates Page A02
A ETC	Profiles Specification Pages Page A03-A08 Technical Information Page A09-A17 Scale Profile Drawings Page A18-A46
B ETC	Accessories Photos & Drawings Page B03-B40
C ETC	Sections Scale Elevations Page C03-C66
D ETC	Statics Page D01-D02
E ETC	Construction Drawings Corner Jointing Page E03-E07 Drainage..... Page E08-E09 Variable Angle Cill detail..... Page E10 Transom/Mullion Fixings..... Page E11-E21 UN3000 Horizontal Coupler..... Page E22 Hinges - System Parameters Page E23-E27 Locking Hardware - System Parameters Page E28-E31 French Casement Detail Page E32-E33 Bead & Glazing Page E34-E38 Bay Pole Details..... Page E39-E42 Internally Glazed Example..... Page E43 Fixing Strap Guide..... Page E44
F ETC	Sawing Tables Cutting Information Page F03-F06

Updates

DATE	PAGE	DESCRIPTION
28-02-17	B.03 - B.28	Updated accessories photos and drawings
05-06-17	B.15	ACET628 mechanical cleat for ETC628 Added
29-09-17	A.16 & A35	Added ETC553 20mm Frame Coupler and ETC557 20mm Frame Extension
	B17 & E07	Added ACET692 Vari-Angle Drilling Jig for ACET618
	A09, A16, A19 & A35	Added ETC618 Square Outer Frame, ETC853 Coupler & UN3000 Coupler
22-02-18	A34 & A35	Removed ETC628 from compatible sections list.
	E30	Added ETC6101, ETC6301 and ETC628 to Internally Beaded Sections Glazing Chart.
	A40	ETC652 supersedes ETC656N.
27-02-18	E10	Added Variable Angle Cill detail
	E20	Added UN3000 Horizontal Coupler detail
01-05-18	Section B	Added ACSM010SS Casement Window Handles Added ACET174 Hinge
22-10-21	All Sections	<p>Sections;</p> <p>ETC367 - Glazing Bead Superseded by ETC369. ETC479 Superseded by ETC479N. ETC6105 - Flush Casement Outer Frame Added. ETC629 - Flat Internally Tap In Glazed Vent Added. ETC6305 - Screwport Flush Casement Transom/Mullion Added. ETC6306 - Mechanically Joined Flush Casement Transom/Mullion Added. ETC640 - Glazing Tap in Bead for ETC629 Added. ETC640G - Glazing Tap in Bead with Gasket for ETC629 Added. ETC649 - French Casement Mullion Added.</p> <p>Accessories;</p> <p>ACDV916 - Bead Punch Tool Added. ACET174 - Door Hinge Removed. ACET179 Superseded by ACET179N. ACET311 - Chevron Added. ACET390 - 25mm Polyamide Screw Added. ACET4036 - Anti-Twist Clip Added. ACET421N - Crimping Cleat Added. ACET479 Superseded by ACET479N. ACET6305 - Cruciform Fixing Plate Added. ACET6306 - Mechanical Transom Cleat Added. ACET642 - Location Block Removed. ACET649 - French Casement End Cap Added. ACET650 - French Casement Keep Added. ACET651 - French Casement Shootbolt Guide Added. ACET653 - 25mm Plastic Infill for ETC648 & ETC649. ACET695 - Glass Adjuster Added. ACET961 - Drill Jig for Glass Adjuster Added. ACET964 - Drill Jig for ETC6305 Added. ACSIL014 Image Updated. ACUN3050 - French Casement Locking Kit Added.</p>

Specification

GENERAL DESCRIPTION

The "Alitherm 600" window system described in this manual is suitable for domestic or commercial applications as replacement windows for existing buildings, and for installation into new buildings.

The system incorporates internally & externally beaded vent frames suitable for cockspur and shootbolt locking.

The low line gaskets and extended polyamide thermal breaks help to provide excellent U Values and Window Energy Rating capable of achieving an 'A' Rating when used in conjunction with the correct double glazed unit. Please refer to the WER calculator for guidance.

Alitherm 600 provides the option of mechanical joints using punch tooling on the majority of sections & crimping corners on all sections.

Kitemark™ Certificate

No. KM 81580

Size Limitations and Performance Characteristics

Alitherm 600 Aluminium Alloy Window System

Window Type	Width (mm) Maximum	Height (mm) Maximum	Weight (kg) Maximum	Area (M ²) Maximum	Friction Stays (up to and including)	Transom/Mullion Length (mm) inc frame - Maximum	Air Permeability classification	Water tightness classification	Resistance to Wind classification	Exposure category as given in Table 1 of BS 6375-1:2009
Sash dimensions for windows with approved sash profiles:										
Projecting top hung Internally beaded	1400	1500	50	-	24"	-	4	9A	AE2400	2000+
Projecting top hung Externally beaded	1400	1500	50	-	24"	-	4	E1200	AE2400	2000+
Projecting side hung Internally beaded	1000	1400	40	-	16"	-	4	9A	AE2400	2000+
Projecting side hung Externally beaded	1000	1400	40	-	16"	-	4	E1200	AE2400	2000+
Overall dimensions for windows with approved outer frame profiles:										
Fixed Internally Beaded	2100	2100	-	4.2	-	-	4	9A	AE2400	2000+
Fixed Externally Beaded	2100	2100	-	4.2	-	-	4	E1200	AE2400	2000+
Overall dimensions for approved outer frames & transom/mullion profiles:										
Multilights* Internally Beaded	2100	2100	-	2.5	-	1200	4	9A	AE2400	2000+
Multilights* Externally Beaded	2100	2100	-	2.5	-	1200	4	E1200	AE2400	2000+

*Transom/mullion subject to lxx/lyy requirements

⚠ Important! ⚠

The size parameters shown against the Kitemark are the maximum allowed without the need for further testing.

Please note these are not necessarily the system parameters which may be smaller or larger.

Please refer to fabrication parameters in this manual.

Please see pages B33, 34 & 35 or more guidance on vent sizes & limitations.

Specification

PROFILE SPECIFICATION

The window frame are constructed of aluminium alloy extrusion to BS EN 755-9 and BS EN 12020, extruded from 6063 T6 alloy. The internal and external extrusions are separated with a polyamide thermal break.

The external aluminium alloy extrusion is pre-treated and finished either:-

- a) Anodised to BS 3987: 1987, grade AA25 to a natural self colour.
- b) Polyester powder organic coating to BS 6496. Dual colour is available.

GENERAL MANUFACTURING

Outer and vent frames are made by cutting the frame profiles with accurate 45° mitred ends using Tungsten Carbide Tipped Saw Blades, operating at approximately 3000 rpm.

The corner joints can be made using mechanically fixed corner cleats by punching the corners using the relevant punch tooling shown in section E of this manual. Alternatively, the corners can be joined using the Alitherm 600 crimping tools to form a cold forged corner joint (made by deforming small slugs of metal into the groove of the corner cleat). All joints should be sealed using an adequate sealant.

The ends of transoms and mullions are profiled to fit the frame and fixed using self-tapping screws with a silicone seal.

On polyester powder coated finishes, great care should be taken to avoid getting gap sealer on visible surfaces and should be removed as soon as possible with a clean cloth.

Care should be exercised when using products not supplied by Smart Systems Ltd as no responsibility can be accepted.

Specification

WINDOW DRAINAGE

As with all dry glazed systems, it is recommended that the window system is adequately drained and ventilated. Refer to drainage details in manual, if in doubt ask The Technical Department.

In order to get maximum performance and weather resistance it is recommended that drips are used over all vents.

OUTER FRAME MANUFACTURING INFORMATION

The outer frame members are cut with 45° mitred ends to the overall size required, measured to the longest point of the metal.

Prior to corner crimping the centre line position of any transoms or mullions should be marked on the outer frame members. Where the transom/mullion runs right through, it should be marked out on both jambs or head and cill members in pairs to ensure accurate alignment of the sections.

Using the marked centre line, Drill the transom/mullion fixing holes using a 5mm dia. drill bit.

Corners are formed by coating the cut faces to be joined with a suitable small gap sealer and by applying a cleat glue into the cleat chamber. Into the mitred corner insert the required corner cleats and, where required, the aluminium corner chevrons. The two mitred ends are then brought together and crimped or mechanically joined. The small gap sealer ensures a permanent joint and guards against the ingress of moisture and joint movement. After joining the corners, special care should be taken to ensure any excess sealer is removed from painted surfaces.

Transoms or mullions are cut with square ends to the sizes calculated on the cutting formula sheets. The ends are then profiled to allow them to fit into the outer frame. Special tooling is available on request to profile the end of transom/mullion.

Prior to fixing of transoms and mullions smear the cut ends with a suitable gap sealer. After fixing, special care should be taken to ensure any excess is cleared from painted surfaces.

Specification

INTERNALLY BEADED VENT

Corners are formed by coating the cut faces to be joined with a suitable gap sealer and by applying a cleat glue into the cleat chamber. In the mitred corner insert the required corner cleats and chevrons. The mitred ends are then brought together and crimped or mechanically joined. The small gap sealer ensures a permanent joint and guards against the ingress of moisture and joint movement. Care should be taken to ensure any excess sealer is removed from the surfaces.

The cutting sizes produce vent frames with a cavity of 14mm or 17mm.

When fixing, the friction stays into both the outer and vent frame, care should be taken to ensure that holes are located on 'V' grooves in the aluminium extrusions.

INTERNALLY BEADED ADAPTOR FRAME

The internally beaded adaptor frame members are cut with 45° mitred ends to the overall size required, measured to the longest point of metal. Care should be taken when measuring and cutting the frame members as only nominal clearance is required when the assembled frame is fixed in the outer frame.

Corners are formed by coating the cut faces to be joined with a suitable small gap sealer and by applying a cleat glue into the cleat chamber. Into the mitred corner insert a corner cleat and the required corner chevrons. The small gap sealer ensures a permanent joint and guards against the ingress of moisture and joint movements. Care should be taken to ensure any excess sealer is removed from painted surfaces.

Specification

MULTI-POINT LOCKING

The vent should be prepped for the locking mechanism prior to fabrication and fitted into vent before hanging. Stainless steel fixing should be used for securing the locking mechanism and keeps in position.

TOP HUNG VENTILATORS WHEN USING COCKSPUR HANDLES

If the width of the ventilator frame is less than 750mm, fit one handle.

If the width of the ventilator is greater than 750mm, fit two handles.

SIDE HUNG VENTILATORS WHEN USING COCKSPUR HANDLES

If the height of the ventilator frame is less than 750mm, fit one handle.

If the height of the ventilator is greater than 750mm, fit two handles.

GLAZING

All beads are cut to suit the glazing aperture on the fully assembled window for glazing either at factory or on site as required. It is advisable to use a gasket roller when using low-line gaskets to ensure a neat finish.

INTERNALLY BEADED GLAZING

Glazing beads are fitted to openings by cutting the horizontal beads square to head and cill of each vent and fixed light area. Vertical beads are cut square at both ends. Insert bottom beads and two setting blocks to ensure glass will be centralised in vertical dimension of opening (glazing blocks must be full width of cavity to fully support glass or sealed unit), then insert top bead followed by side beads. Finish glazing by insertion of internal gaskets all round. Note that a small notch is required to the beads ETC367 & ETC273 when used with ETC621 vent as shown in section E. **Please be aware that the co-extruded tap in bead is only available in black, white and KL005.**

For maximum weather performance, apply silicone to the full width of the bottom bead and 100mm up from the bottom of the vertical beads.

Specification

The below is a summary of the window testing under Kitemark Licence Number: KM81580. The full details may be downloaded from www.smartsystems.co.uk

Alitherm 600 Window Weather Performance (BS6375-1:2009)

BS EN 1026: 2000 Air Permeability:	Class 4 600Pa
BS EN 1027: 2000 Watertightness:	Class E 1200Pa
BS EN 12211: 2000 Resistance to Wind Load:	Class E 2400Pa

Alitherm 600 Operational Performance (BS6375-2:2009)

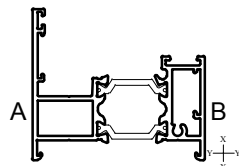
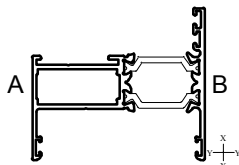
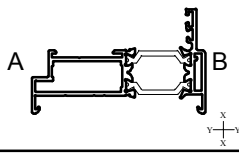
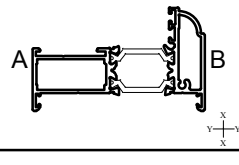
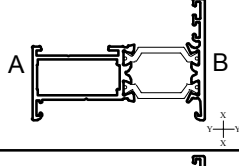
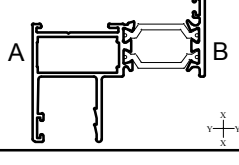
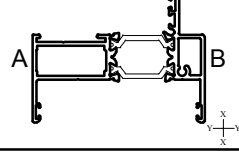
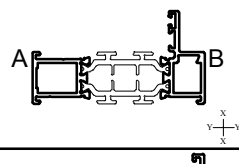
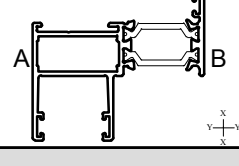
Alitherm 600 has passed the operational & strength requirements of of BS6375-2

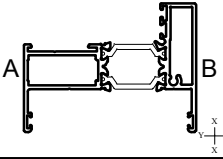
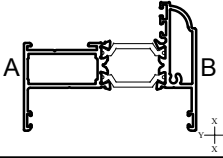
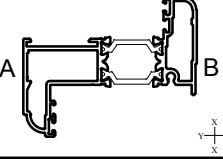
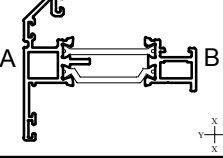
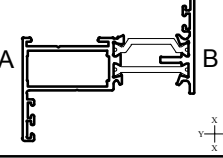
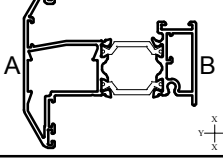
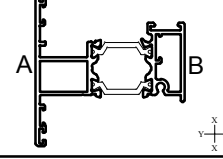
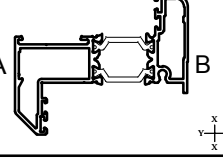
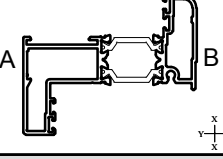
Alitherm 600 Window Security (PAS24:2016)

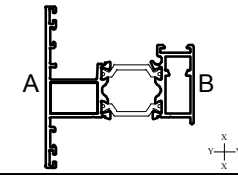
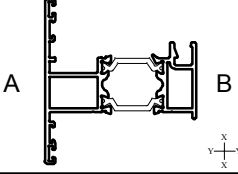
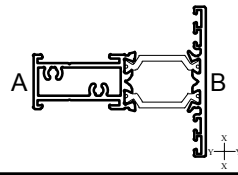
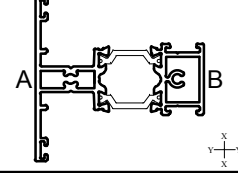
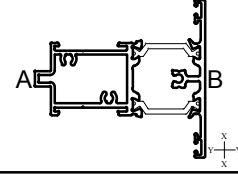
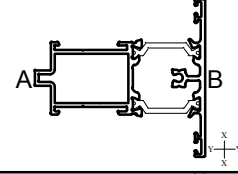
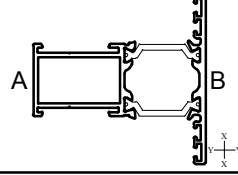
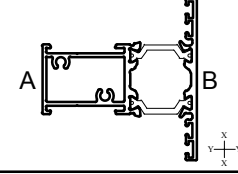
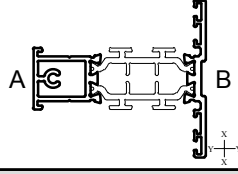
Internally beaded top hung & side hung sashes have successfully tested to BS7950. Please contact our Technical Department (T:01934 876100) for further information.

Alitherm 600 Window U Values

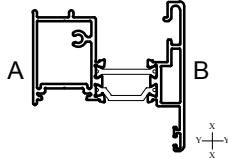
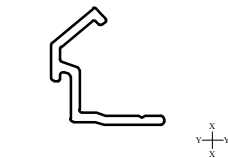
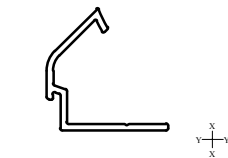
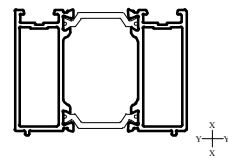
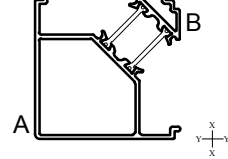
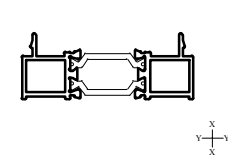
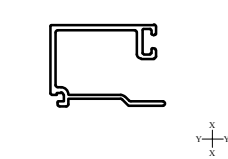
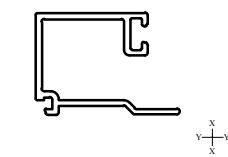
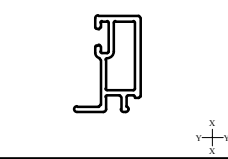
Please refer to the Smart Systems' Document L White Paper or contact the Technical Department.

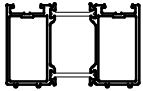
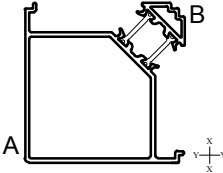
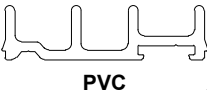
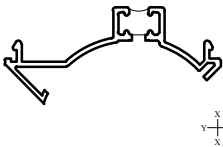
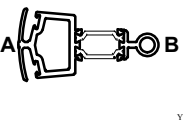

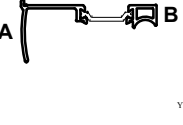
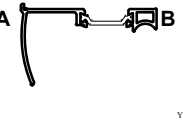
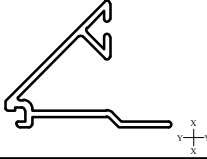
Number	Picture	Page	Perim. mm	Mec. mm	lx(cm4) wx(cm3)	ly(cm4) wy(cm3)	Length	Pack pr.	MF	SA	KL	HP	M	
ETC6101		A18	363	93	20.80 ----- 6.71	5.94 ----- 2.91	6.5	1	✓	✓	✓	✓	✓	
ETC610		A18	358	94	17.66 ----- 5.45	4.72 ----- 1.77	6.5	1	✓	✓	✓	✓	✓	
ETC6105		A21	293	85	20.67 ----- 5.26	2.85 ----- 1.70	6.5	1	✓	✓	✓	✓	✓	
ETC611		A18	327	79	22.60 ----- 5.69	3.80 ----- 2.12	6.5	1	✓	✓	✓	✓	✓	
ETC612		A19	309	74	14.81 ----- 4.53	2.72 ----- 1.58	6.5	1	✓	✓	✓	✓	✓	
ETC613		A19	364	84	16.14 ----- 5.00	6.01 ----- 2.11	6.5	1	✓	✓	✓	✓	✓	
ETC614		A19	377	113	25.44 ----- 6.62	4.75 ----- 1.88	6.5	1	✓	✓	✓	✓	✓	
ETC615		A20	269	81	19.74 ----- 5.16	2.35 ----- 1.74	6.5	1	✓	✓	✓	✓	✓	
ETC616		A20	376	84	16.06 ----- 5.05	6.18 ----- 2.19	6.5	1	✓	✓	✓	✓	✓	
									A = Outside B = Inside		MF = Mill Finish SA = Silver Anodised KL = Basic Colour HP = Special Colour M = Dual Colour			

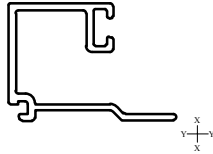
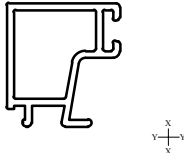
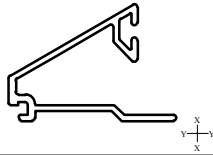
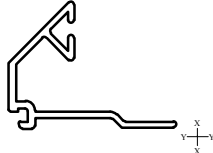
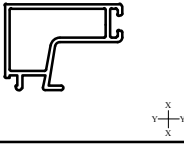
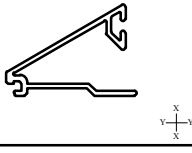
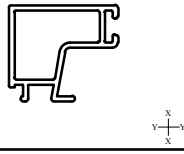
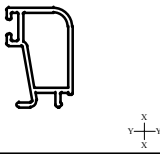
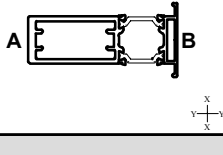
Number	Picture	Page	Perim. mm	Mec. mm	lx(cm4) wx(cm3)	ly(cm4) wy(cm3)	Length	Pack pr.	MF	SA	KL	HP	M	
ETC618		A20	343	111	27.62 ----- 6.89	6.38 ----- 2.5	6.5	1	✓	✓	✓	✓	✓	
ETC619		A21	374	86	26.66 ----- 6.76	5.68 ----- 2.17	6.5	1	✓	✓	✓	✓	✓	
ETC620		A22	354	104	25.82 ----- 7.39	7.07 ----- 2.65	6.5	1	✓	✓	✓	✓	✓	
ETC621		A22	338	84	14.61 ----- 3.86	3.8 ----- 1.57	6.5	1	✓	✓	✓	✓	✓	
ETC622		A23	336	83	16.45 ----- 5.49	3.61 ----- 1.41	6.5	1	✓	✓	✓	✓	✓	
ETC623		A23	410	111	28.50 ----- 7.49	10.17 ----- 3.17	6.5	1	✓	✓	✓	✓	✓	
ETC624		A24	405	107	22.15 ----- 6.47	7.96 ----- 2.46	6.5	1	✓	✓	✓	✓	✓	
ETC625		A24	352	103	26.92 ----- 7.33	7.60 ----- 2.87	6.5	1	✓	✓	✓	✓	✓	
ETC627		A25	357	103	26.67 ----- 7.75	7.75 ----- 2.84	6.5	1	✓	✓	✓	✓	✓	
									A = Outside B = Inside		MF = Mill Finish SA = Silver Anodised KL = Basic Colour HP = Special Colour M = Dual Colour			

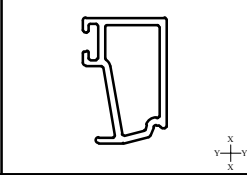
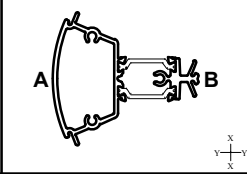
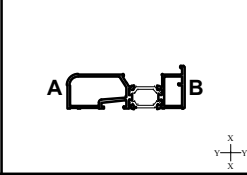
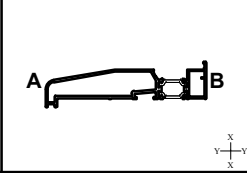
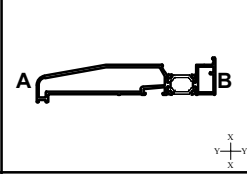
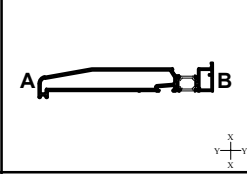
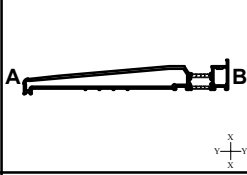
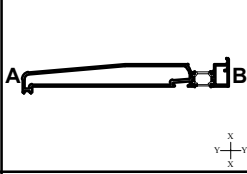
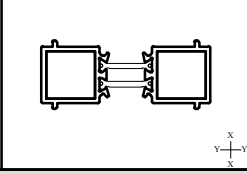
Number	Picture	Page	Perim. mm	Mec. mm	lx(cm4) wx(cm3)	ly(cm4) wy(cm3)	Length	Pack pr.	MF	SA	KL	HP	M	
ETC628		A25	397	107	21.67 ----- 6.24	7.93 ----- 2.44	6.5	1	✓	✓	✓	✓	✓	
ETC629		A26	401	107	21.37 ----- 6.10	7.55 ----- 2.36	6.5	1	✓	✓	✓	✓	✓	
ETC630		A27	342	84	16.25 ----- 4.73	3.57 ----- 1.38	6.5	1	✓	✓	✓	✓	✓	
ETC6301		A27	380	92	19.87 ----- 5.81	5.28 ----- 1.82	6.5	1	✓	✓	✓	✓	✓	
ETC6305		A29	333	115	22.18 ----- 5.60	6.82 ----- 2.24	6.5	1	✓	✓	✓	✓	✓	
ETC6306		A29	323	115	20.96 ----- 5.13	6.65 ----- 2.18	6.5	1	✓	✓	✓	✓	✓	
ETC631		A28	366	95	16.68 ----- 4.70	5.59 ----- 1.92	6.5	1	✓	✓	✓	✓	✓	
ETC632		A28	366	93	18.04 ----- 5.31	5.68 ----- 1.96	6.5	1	✓	✓	✓	✓	✓	
ETC634		A30	302	116	18.15 ----- 5.35	3.81 ----- 1.40	6.5	1	✓	✓	✓	✓	✓	
									A = Outside B = Inside		MF = Mill Finish SA = Silver Anodised KL = Basic Colour HP = Special Colour M = Dual Colour			

Number	Picture	Page	Perim. mm	Mec. mm	lx(cm4) wx(cm3)	ly(cm4) wy(cm3)	Length	Pack pr.	MF	SA	KL	HP	M	
ETC635		A30	395	137	36.62 ----- 7.34	6.13 ----- 2.12	6.5	1	✓	✓	✓	✓	✓	
ETC636		A31	349	204	84.97 ----- 13.57	9.99 ----- 3.45	6.5	1	✓	✓	✓	✓	✓	
ETC638		A31	368	110	23.47 ----- 5.63	6.12 ----- 2.11	6.5	1	✓	✓	✓	✓	✓	
ETC639		A32	588	194	34.49 ----- 10.71	57.72 ----- 10.59	6.5	1	✓	✓	✓	✓	✓	
ETC640		A26	120	39	- ----- -	- ----- -	6.5	1	✓	✓	✓	✓		
ETC640G		A26	120	39	- ----- -	- ----- -	6.5	1	AVAILABLE IN: BL, WP & KL005					
ETC645		A35	293	56	11.88 ----- 3.30	2.45 ----- 1.21	6.5	1	✓	✓	✓	✓	✓	
ETC647		A35	284	44	10.15 ----- 4.59	1.74 ----- 1.04	6.5	1	✓	✓	✓	✓		
ETC648		A35	333	97	19.64 ----- 5.84	6.87 ----- 3.17	6.5	1	✓	✓	✓	✓	✓	
									A = Outside B = Inside		MF = Mill Finish SA = Silver Anodised KL = Basic Colour HP = Special Colour M = Dual Colour			

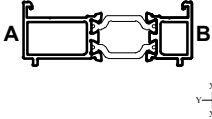
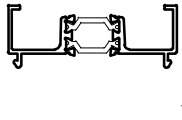
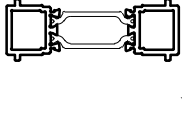
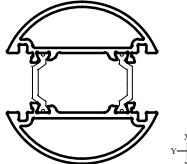


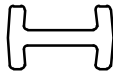
Number	Picture	Page	Perim. mm	Mec. mm	lx(cm4) wx(cm3)	ly(cm4) wy(cm3)	Length	Pack pr.	MF	SA	KL	HP	M	
ETC649		A35	357	118	21.8 ----- 6.69	8.62 ----- 3.42	6.5	1	✓	✓	✓	✓	✓	
ETC650		A44	84	19	- ----- -	- ----- -	6.5	1	✓	✓	✓	✓		
ETC651		A44	128	32	- ----- -	- ----- -	6.5	1	✓	✓	✓	✓		
ETC652		A43	244	89	19.01 ----- 6.38	8.94 ----- 4.2	6.5	1	✓	✓	✓	✓	✓	
ETC655		A43	370	111	23.17 ----- 7.29	23.17 ----- 7.65	6.5	1	✓	✓	✓	✓	✓	
ETC660		A43	220	34	10.78 ----- 3.62	0.93 ----- 1.02	6.5	1	✓	✓	✓	✓	✓	
ETC664		A36	166	77	- ----- -	- ----- -	6.5	1	✓	✓	✓	✓		
ETC665		A36	158	38	- ----- -	- ----- -	6.5	1	✓	✓	✓	✓		
ETC667		A38	78	24	- ----- -	- ----- -	6.5	1	✓	✓	✓	✓		
									A = Outside B = Inside		MF = Mill Finish SA = Silver Anodised KL = Basic Colour HP = Special Colour M = Dual Colour			

Number	Picture	Page	Perim. mm	Mec. mm	Ix(cm4) wx(cm3)	Iy(cm4) wy(cm3)	Length	Pack pr.	MF	SA	KL	HP	M	
DV515		A34	356	85	27.16 ----- 7.76	14.38 ----- 6.75	6.5	1	✓	✓	✓	✓	✓	
ETC048		A33	414	152	42.64 ----- 11.72	42.64 ----- 11.81	6.5	1	✓	✓	✓	✓	✓	
ETC052		A33	242	-	- ----- -	- ----- -	4	1	✓					
ETC150		A33	282	36	11.28 ----- 3.22	1.12 ----- 0.74	6.5	1	✓	✓	✓	✓		
ETC080		A45	334	61	25.58 ----- 5.47	4.88 ----- 2.57	6.5	1	✓	✓	✓	✓		
ETC081		A45	197	35	13.85 ----- 3.8	0.36 ----- 0.52	6.5	1	✓	✓	✓	✓	✓	
ETC082		A45	221	47	16.21 ----- 4.19	1.15 ----- 1.29	6.5	1	✓	✓	✓	✓	✓	
ETC083		A45	243	58	17.66 ----- 4.32	2.64 ----- 2.36	6.5	1	✓	✓	✓	✓	✓	
ETC262		A37	131	25	- ----- -	- ----- -	6.5	1	✓	✓	✓	✓		
									A = Outside B = Inside		MF = Mill Finish SA = Silver Anodised KL = Basic Colour HP = Special Colour M = Dual Colour			

Number	Picture	Page	Perim. mm	Mec. mm	lx(cm4) wx(cm3)	ly(cm4) wy(cm3)	Length	Pack pr.	MF	SA	KL	HP	M	
ETC265		A37	152	35	- ----	- ----	6.5	1	✓	✓	✓	✓		
ETC267		A38	90	32	- ----	- ----	6.5	1	✓	✓	✓	✓		
ETC268		A36	142	31	- ----	- ----	6.5	1	✓	✓	✓	✓		
ETC269		A37	127	24	- ----	- ----	6.5	1	✓	✓	✓	✓		
ETC270		A38	106	40	- ----	- ----	6.5	1	✓	✓	✓	✓		
ETC271		A36	146	32	- ----	- ----	6.5	1	✓	✓	✓	✓		
ETC272		A38	98	36	- ----	- ----	6.5	1	✓	✓	✓	✓		
ETC273		A39	88	30	- ----	- ----	6.5	1	✓	✓	✓	✓		
ETC357		A34	298	73	41.51 ----	5.20 ----	6.5	1	✓	✓	✓	✓	✓	
									A = Outside B = Inside		MF = Mill Finish SA = Silver Anodised KL = Basic Colour HP = Special Colour M = Dual Colour			

Number	Picture	Page	Perim. mm	Mec. mm	lx(cm4) wx(cm3)	ly(cm4) wy(cm3)	Length	Pack pr.	MF	SA	KL	HP	M	
ETC369		A39	82	19	- ----- -	- ----- -	6.5	1	✓	✓	✓	✓		
ETC385		A44	357	65	26.65 ----- 6.53	12.38 ----- 3.83	6.5	1	✓	✓	✓	✓	✓	
ETC451		A40	304	109	32.44 ----- 7.29	3.46 ----- 2.79	6.5	1	✓	✓	✓	✓	✓	
ETC452		A40	414	197	122.46 ----- 18.03	6.01 ----- 3.34	6.5	1	✓	✓	✓	✓	✓	
ETC457		A40	444	212	163.27 ----- 21.60	6.79 ----- 3.73	6.5	1	✓	✓	✓	✓	✓	
ETC458		A41	524	252	313.62 ----- 32.63	8.87 ----- 4.79	6.5	1	✓	✓	✓	✓	✓	
ETC477		A42	752	408	1591.6 ----- 105.33	26.84 ----- 12.84	5	1	✓	✓	✓	✓	✓	
ETC479N		A41	594	287	501.64 ----- 44.04	9.72 ----- 5.34	6.5	1	✓	✓	✓	✓	✓	
ETC553		A39	202	75	12.06 ----- 4.05	1.67 ----- 1.39	6.5	1	✓	✓	✓	✓	✓	
									A = Outside B = Inside		MF = Mill Finish SA = Silver Anodised KL = Basic Colour HP = Special Colour M = Dual Colour			

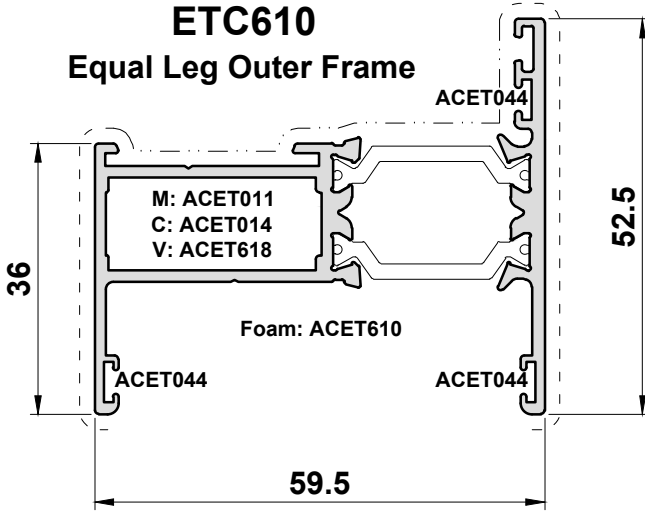
PROFILES : SPECIFICATION

Number	Picture	Page	Perim. mm	Mec. mm	lx(cm4) wx(cm3)	ly(cm4) wy(cm3)	Length	Pack pr.	MF	SA	KL	HP	M	
ETC557		A39	197	79	17.47 ----- 4.31	1.5 ----- 1.45	6.5	1	✓	✓	✓	✓	✓	
ETC559		A34	318	41	15.75 ----- 4.5	1.17 ----- 0.98	6.5	1	✓	✓	✓	✓	✓	
ETC853		A39	230	41	23.28 ----- 6.65	1.94 ----- 1.4	6.5	1	✓	✓	✓	✓	✓	
ETC869		A44	332	157	19.10 ----- 6.37	14.78 ----- 5.34	6.5	1	✓	✓	✓	✓	✓	
UN3000		A39	200	52	15.8 ----- 4.51	0.79 ----- 0.84	6.5	1	✓	✓	✓	✓	✓	
VL72		A44	101	32	- ----- -	- ----- -	6.5	5	✓	✓	✓	✓		
VL75		A44	54	54	- ----- -	- ----- -	6.5	1	✓					
									A = Outside B = Inside		MF = Mill Finish SA = Silver Anodised KL = Basic Colour HP = Special Colour M = Dual Colour			

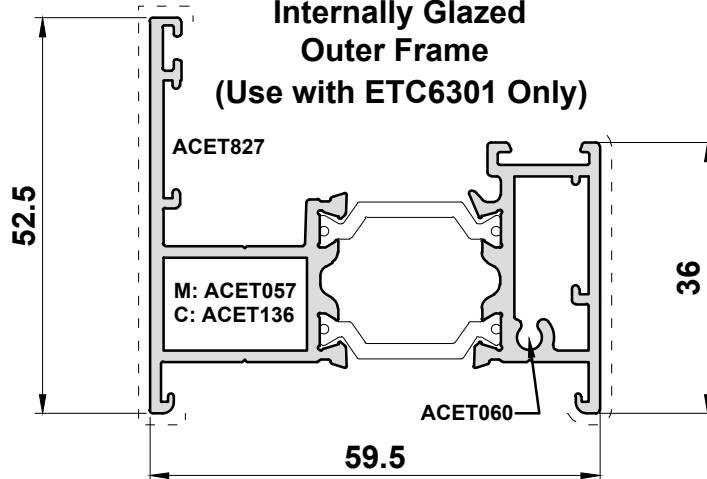
Primary Visible Side

Secondary Visible Side

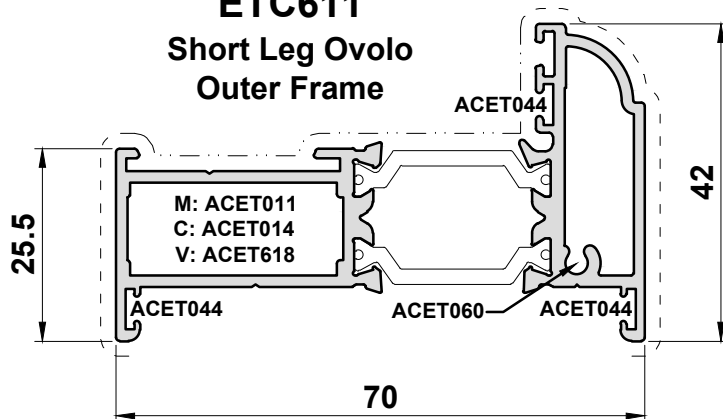
ETC610
Equal Leg Outer Frame



ETC6101
Internally Glazed
Outer Frame
(Use with ETC6301 Only)



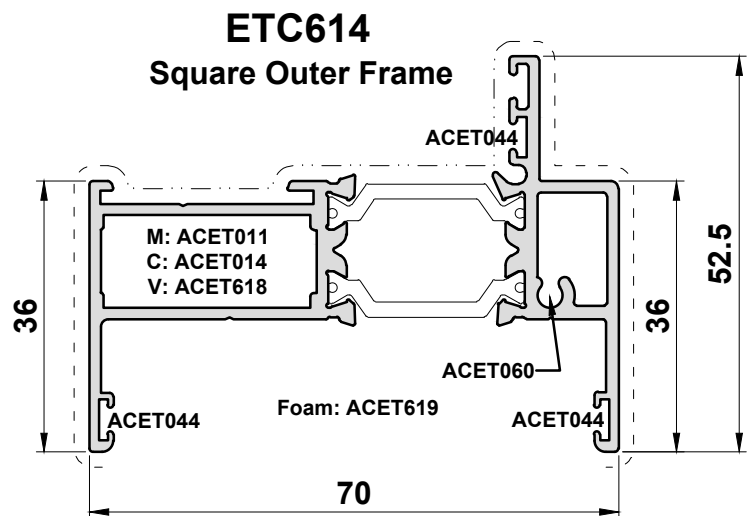
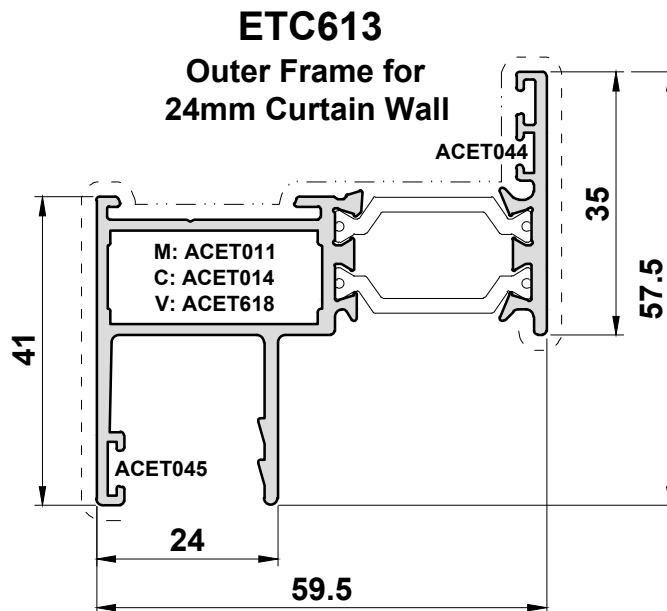
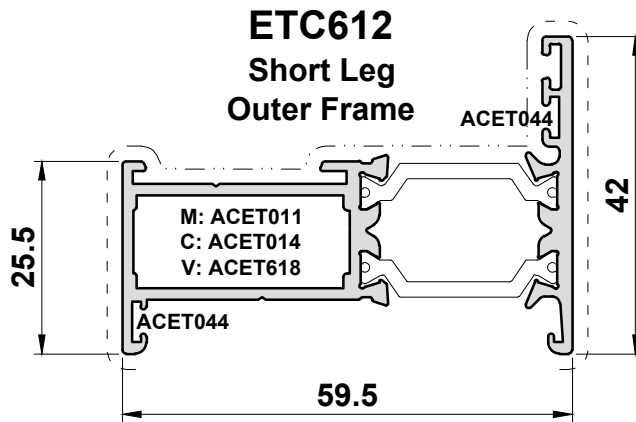
ETC611
Short Leg Ovolo
Outer Frame



SCALE : 1:1

Primary Visible Side

Secondary Visible Side

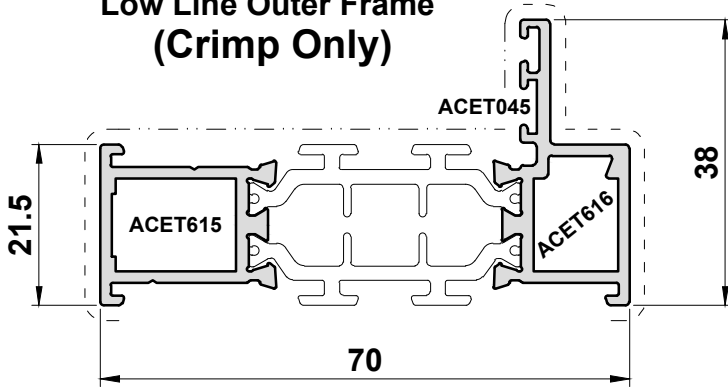


SCALE : 1:1

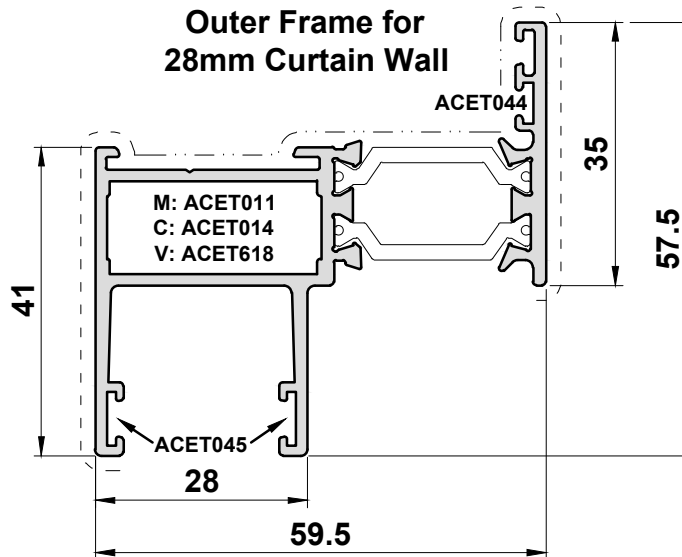
Primary Visible Side

Secondary Visible Side

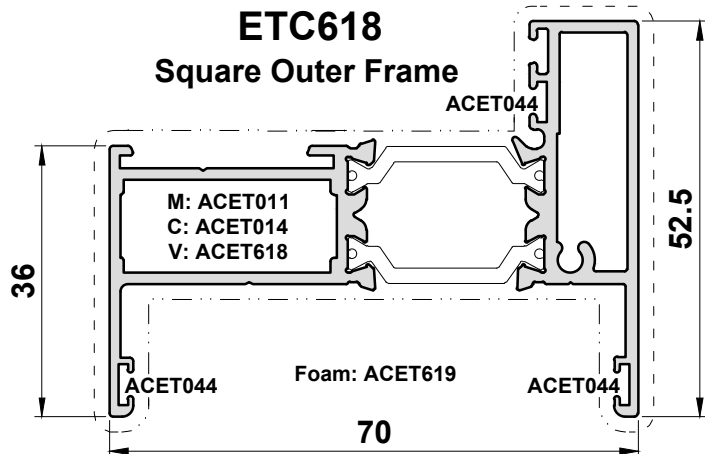
ETC615
Low Line Outer Frame
(Crimp Only)



ETC616
Outer Frame for
28mm Curtain Wall



ETC618
Square Outer Frame

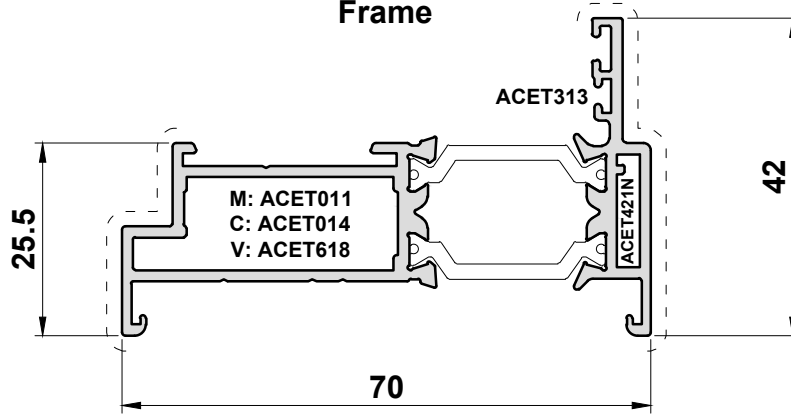


SCALE : 1:1

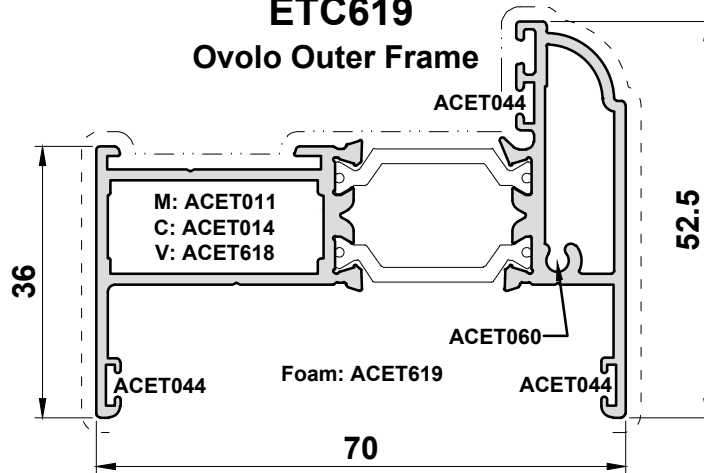
Primary Visible Side

Secondary Visible Side

ETC6105
Flush Casement Outer
Frame



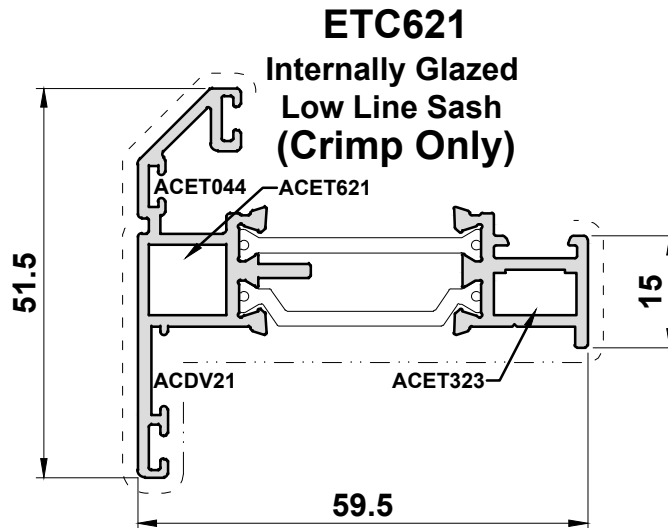
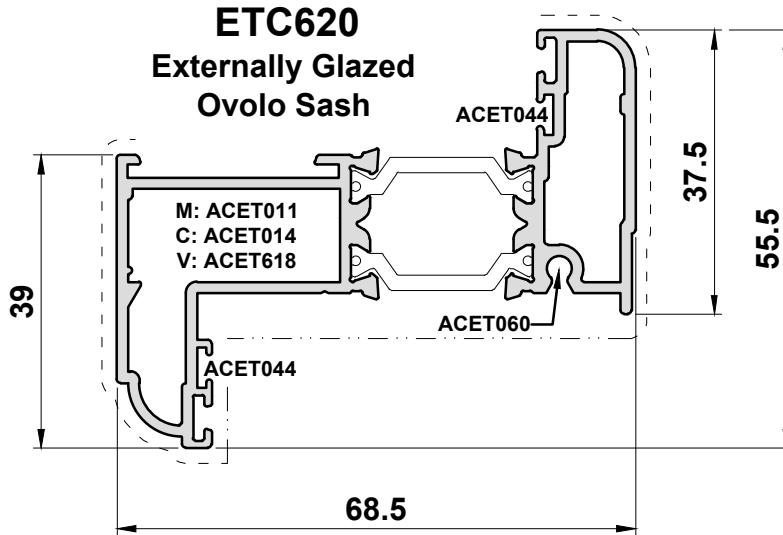
ETC619
Ovolo Outer Frame



SCALE : 1:1

Primary Visible Side

Secondary Visible Side

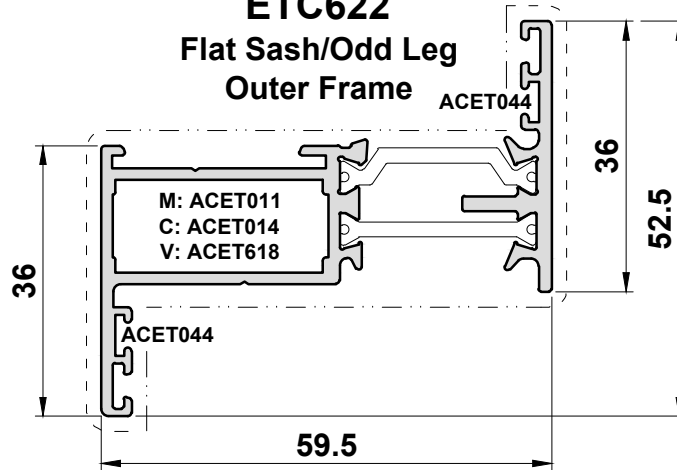


SCALE : 1:1

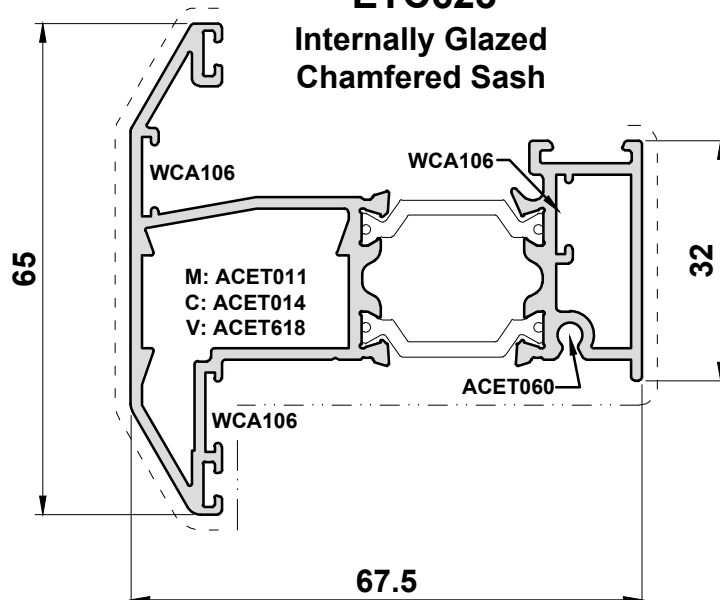
Primary Visible Side

Secondary Visible Side

ETC622
Flat Sash/Odd Leg
Outer Frame



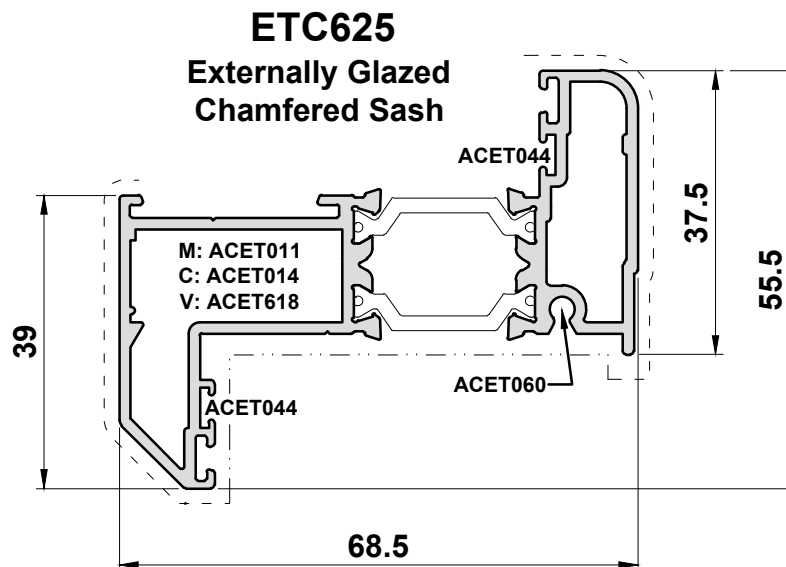
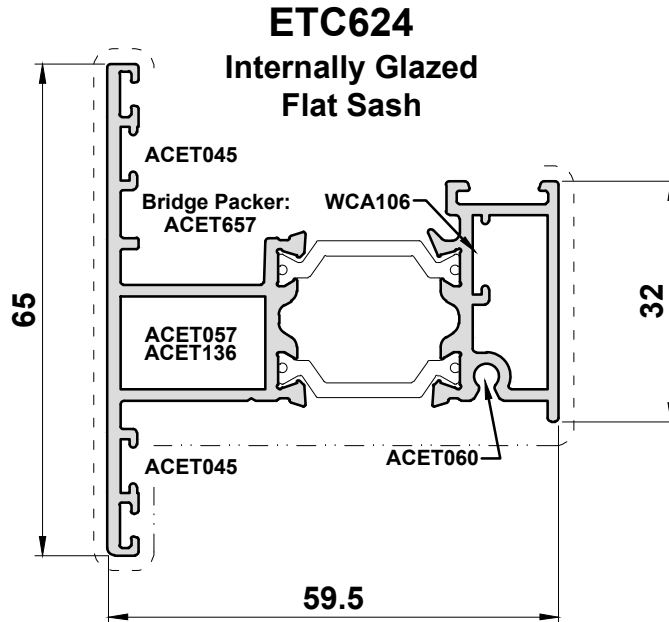
ETC623
Internally Glazed
Chamfered Sash



SCALE : 1:1

Primary Visible Side

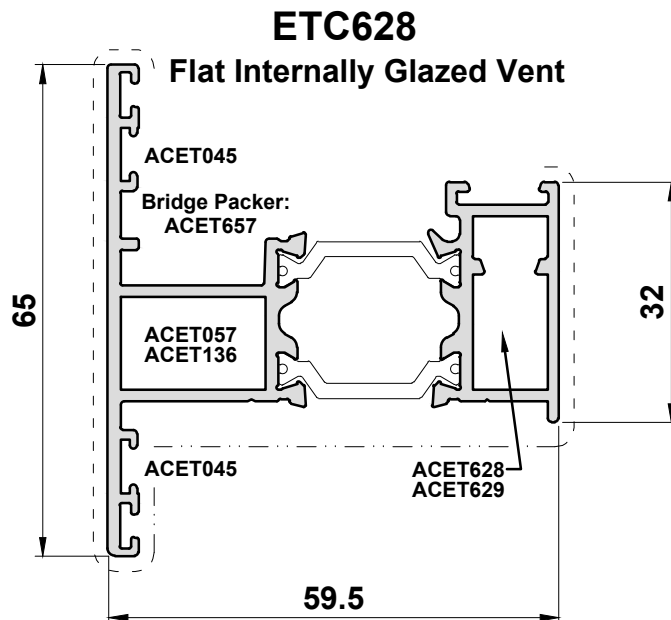
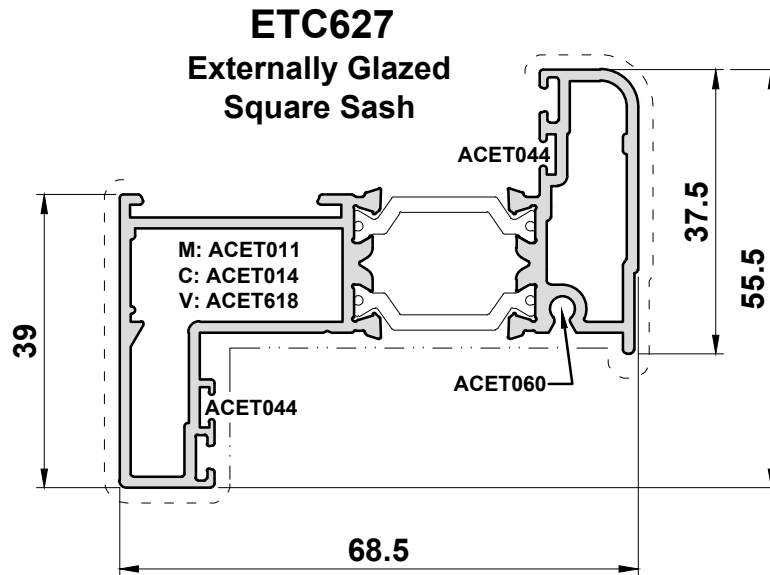
Secondary Visible Side



SCALE : 1:1

Primary Visible Side

Secondary Visible Side



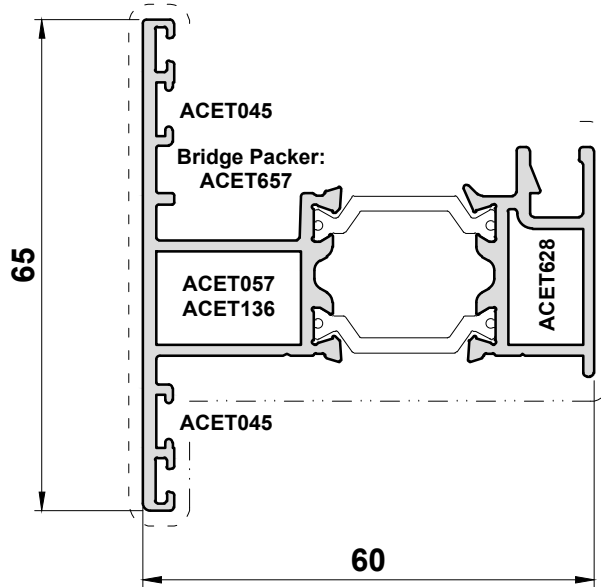
SCALE : 1:1

Primary Visible Side

Secondary Visible Side

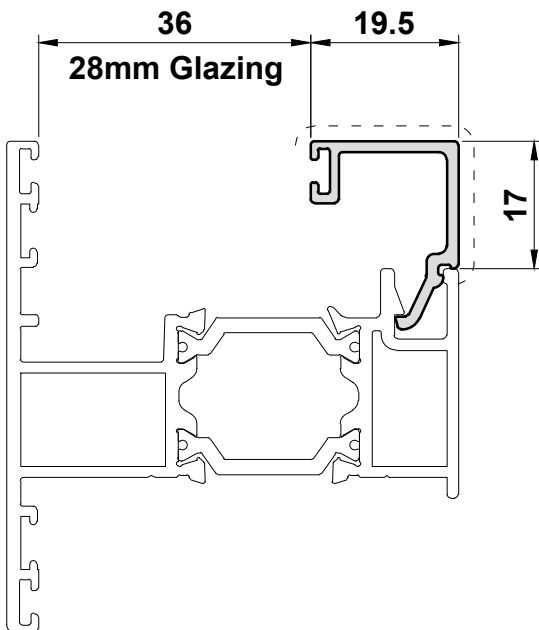
ETC629

Flat Internally Glazed Vent



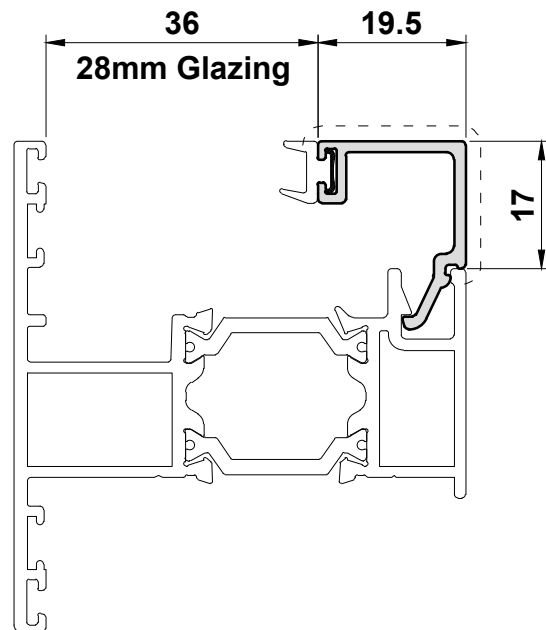
ETC640

28mm Square Bead



ETC640G

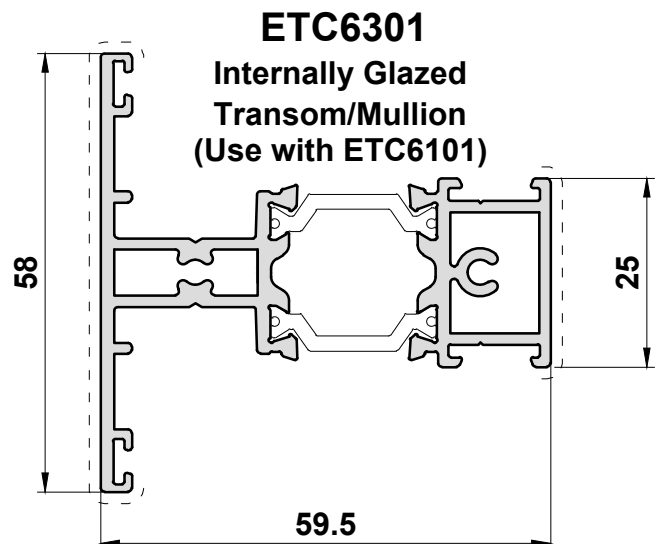
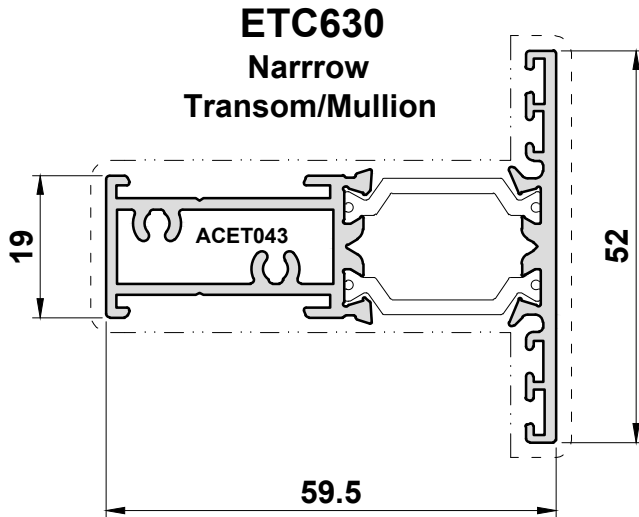
28mm Square Bead



SCALE : 1:1

Primary Visible Side

Secondary Visible Side

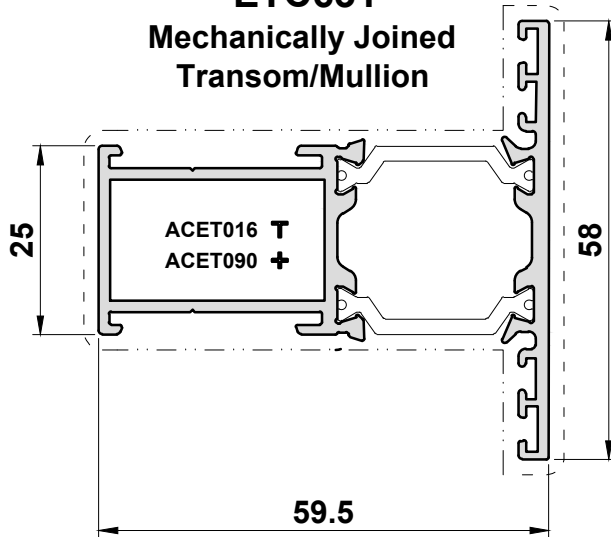


SCALE : 1:1

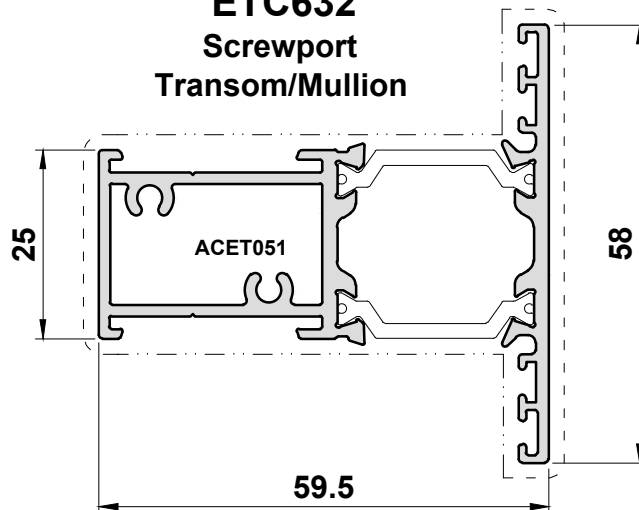
Primary Visible Side

Secondary Visible Side

ETC631
Mechanically Joined
Transom/Mullion



ETC632
Screwport
Transom/Mullion

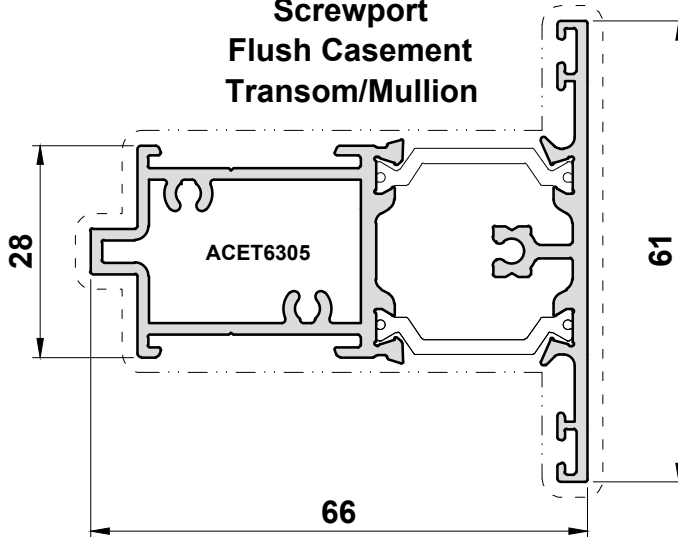


SCALE : 1:1

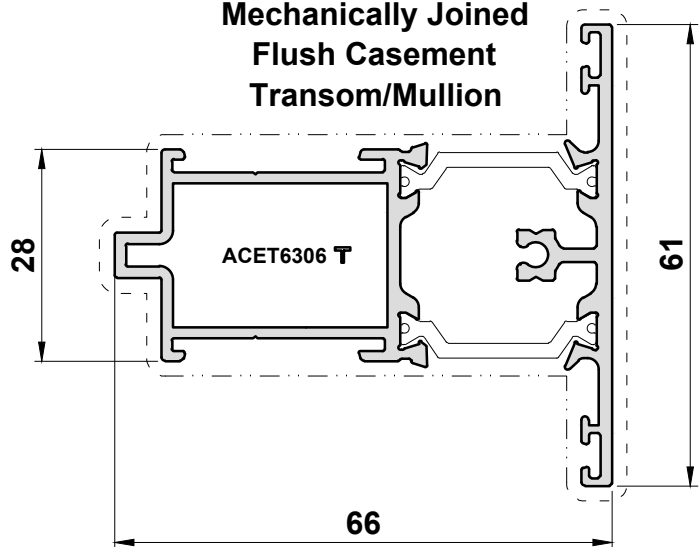
Primary Visible Side

Secondary Visible Side

ETC6305
Screwport
Flush Casement
Transom/Mullion



ETC6306
Mechanically Joined
Flush Casement
Transom/Mullion

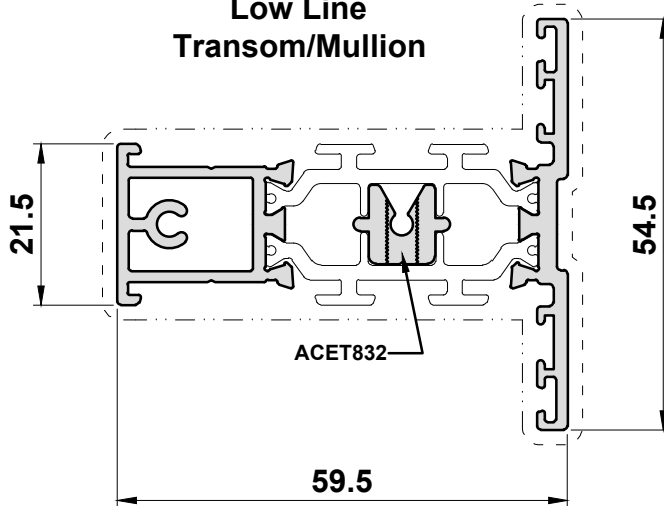


SCALE : 1:1

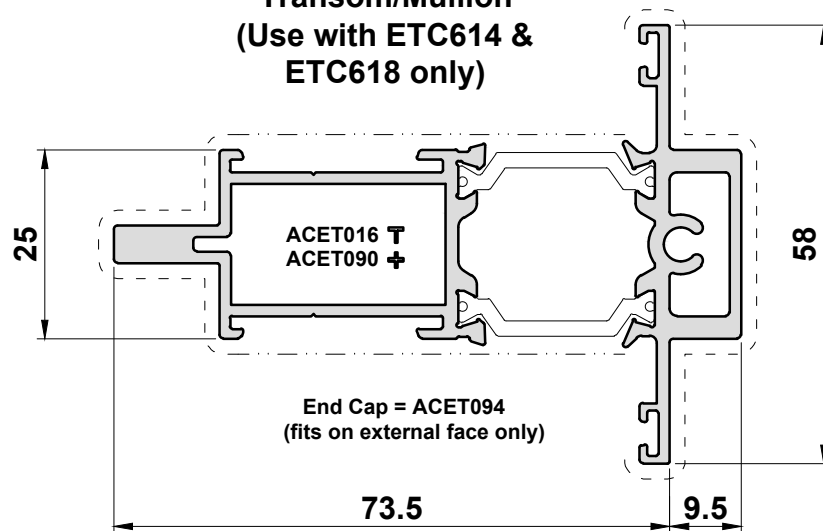
Primary Visible Side

Secondary Visible Side

ETC634
Low Line
Transom/Mullion



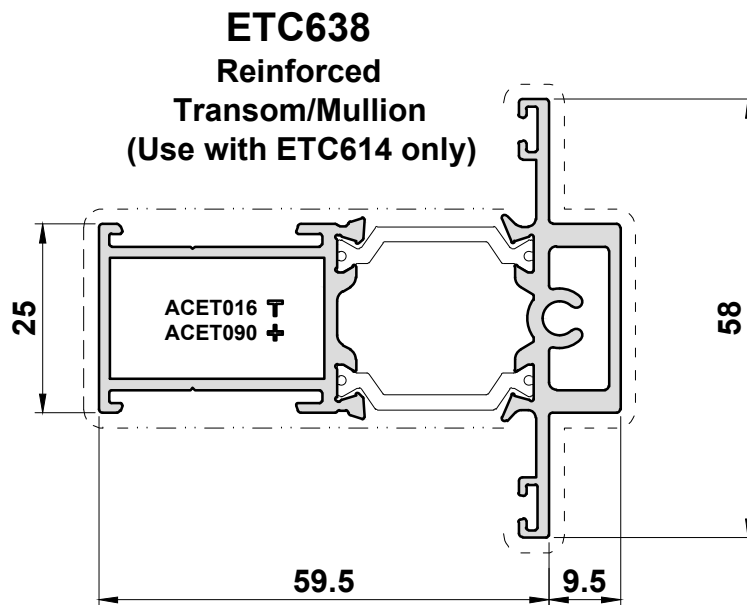
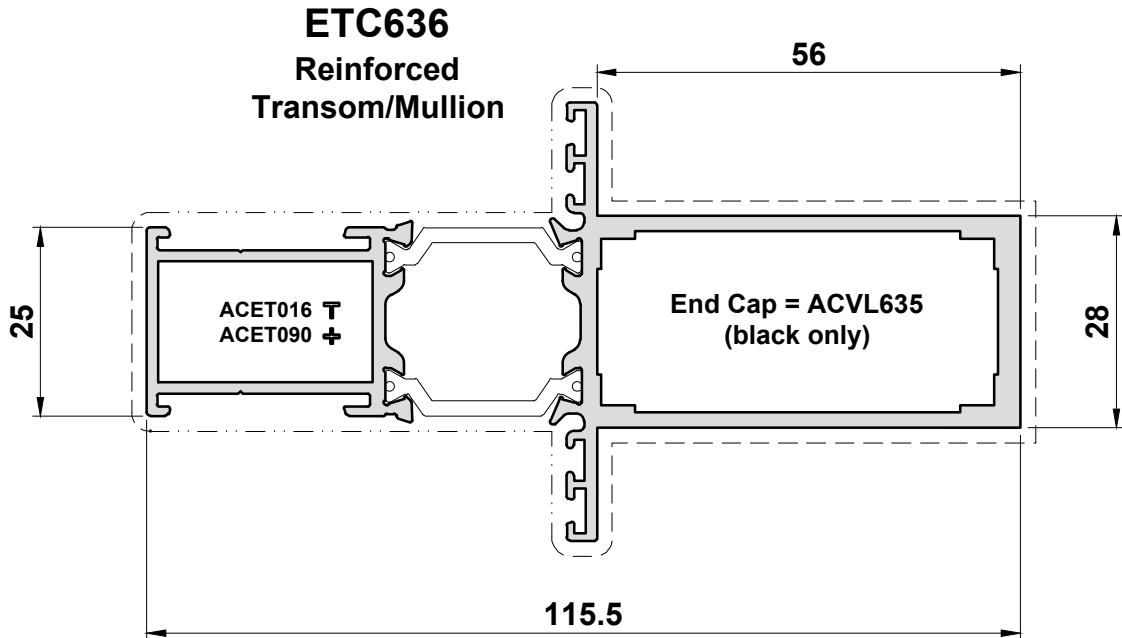
ETC635
Reinforced
Transom/Mullion
(Use with ETC614 &
ETC618 only)



SCALE : 1:1

Primary Visible Side

Secondary Visible Side

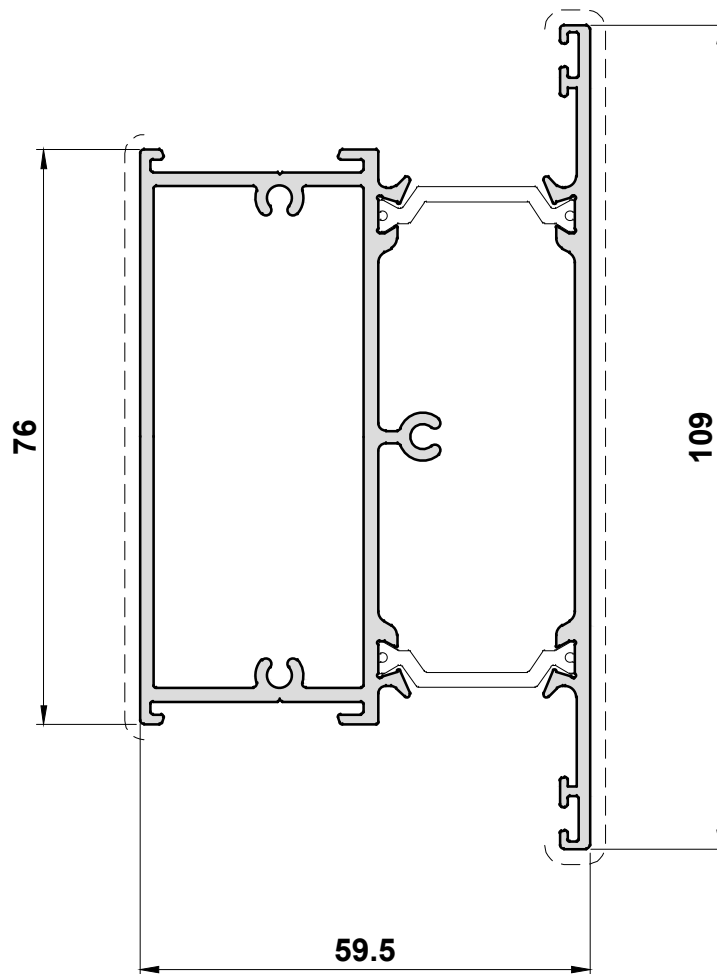


SCALE : 1:1

Primary Visible Side

Secondary Visible Side

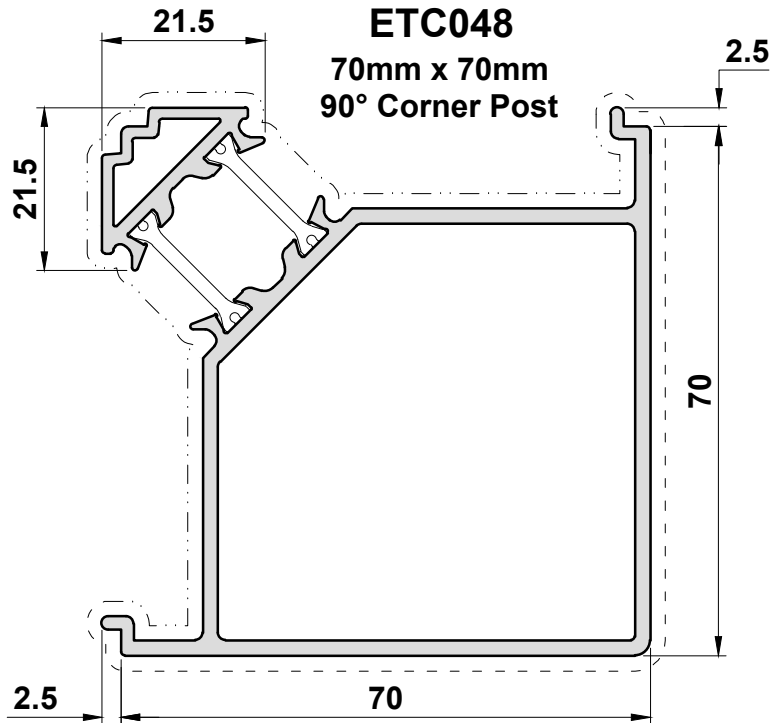
ETC639
109mm Transom To Match
Alitherm Doors



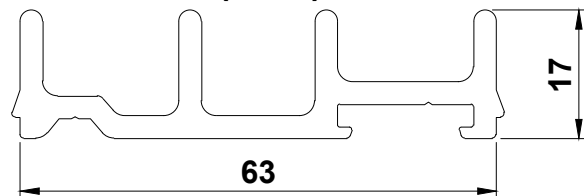
SCALE : 1:1

Primary Visible Side

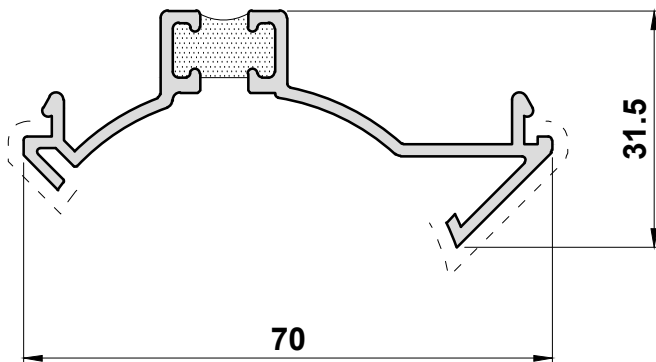
Secondary Visible Side



ETC052
ETC614 & ETC619 Closer
(PVC)



ETC150
Bay Pole Adaptor
(Dual Colour Not Available)

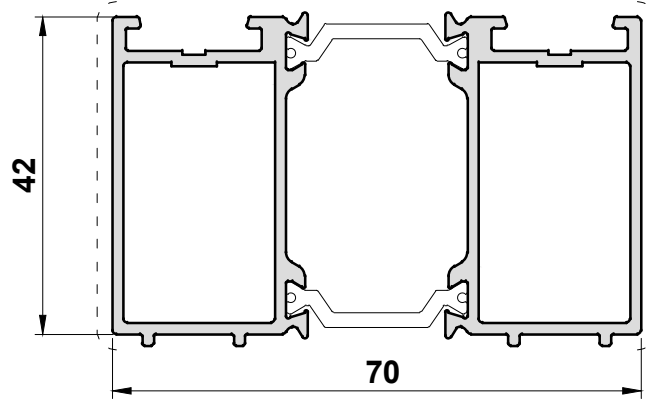


SCALE : 1:1

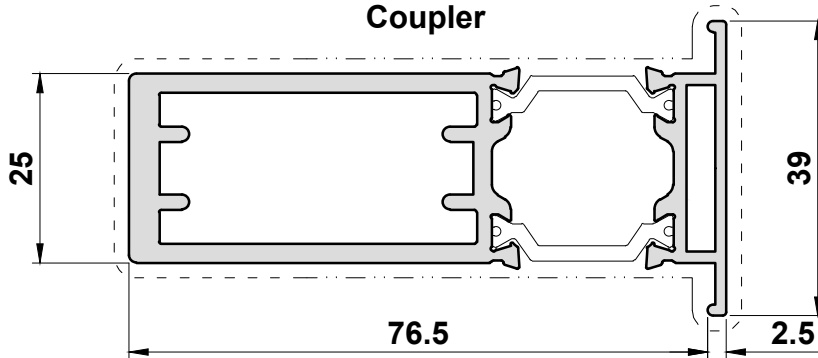
Primary Visible Side

Secondary Visible Side

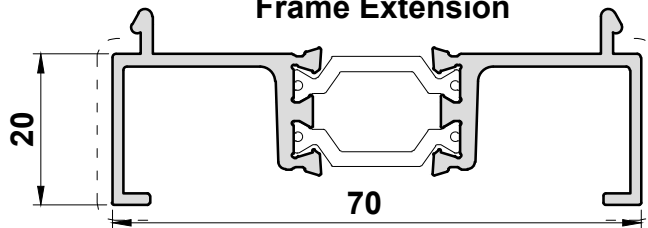
DV515
70mm Head Extension



ETC357
Coupler



ETC559
Frame Extension

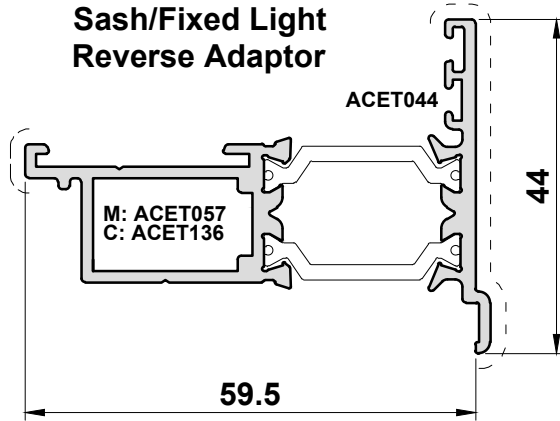


SCALE : 1:1

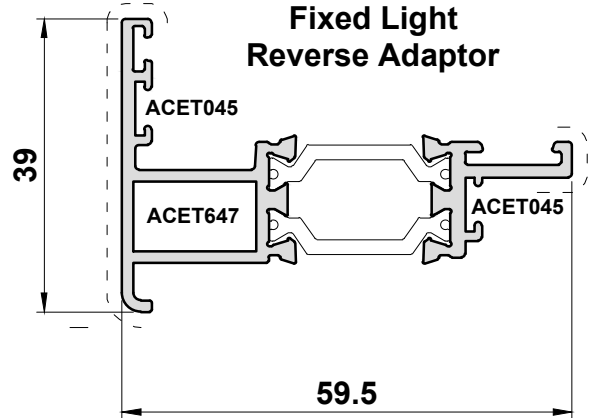
Primary Visible Side

Secondary Visible Side

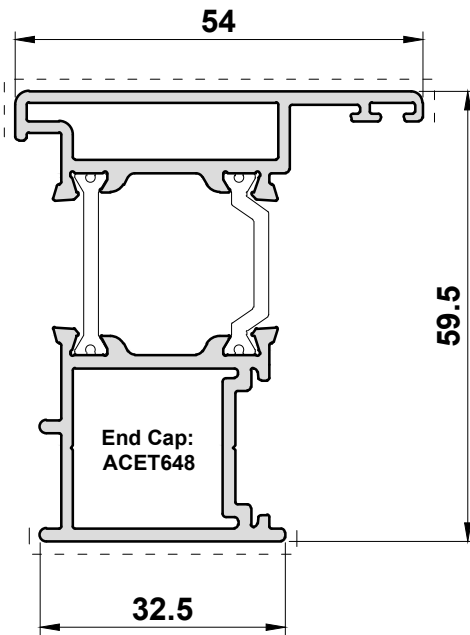
ETC645
Sash/Fixed Light
Reverse Adaptor



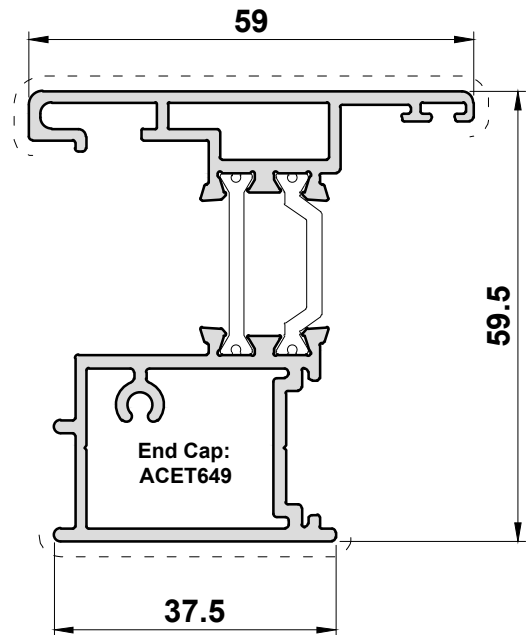
ETC647
Fixed Light
Reverse Adaptor



ETC648
Meeting Stile For French
Casement



ETC649
Meeting Stile For French
Casement



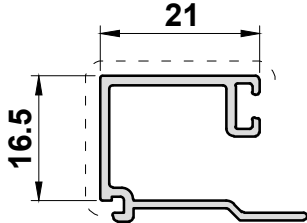
SCALE : 1:1

Primary Visible Side

Secondary Visible Side

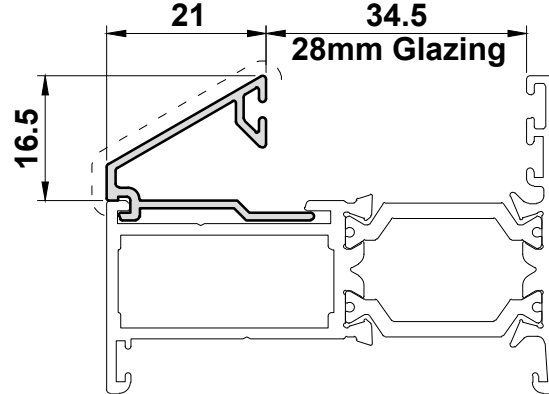
ETC665

28mm Square Bead



ETC268

28mm Sloped Bead

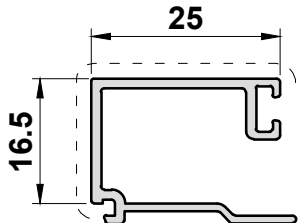


The Bead Shown here
is compatible with:

- | | | |
|--------|--------|--------|
| ETC610 | ETC620 | ETC630 |
| ETC611 | ETC622 | ETC631 |
| ETC612 | ETC625 | ETC632 |
| ETC613 | ETC627 | ETC634 |
| ETC614 | | ETC635 |
| ETC615 | | ETC636 |
| ETC616 | | ETC638 |
| ETC619 | | ETC645 |

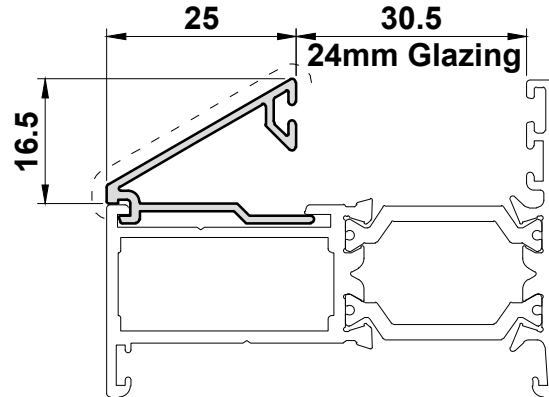
ETC664

24mm Square Bead



ETC271

24mm Sloped Bead



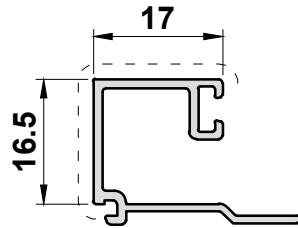
SCALE : 1:1

Primary Visible Side

Secondary Visible Side

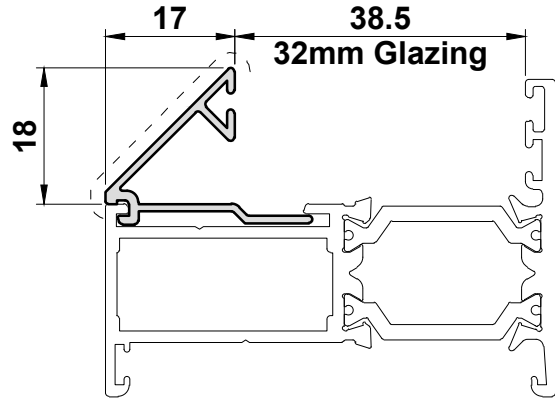
ETC265

32mm Square Bead



ETC262

32mm Sloped Bead

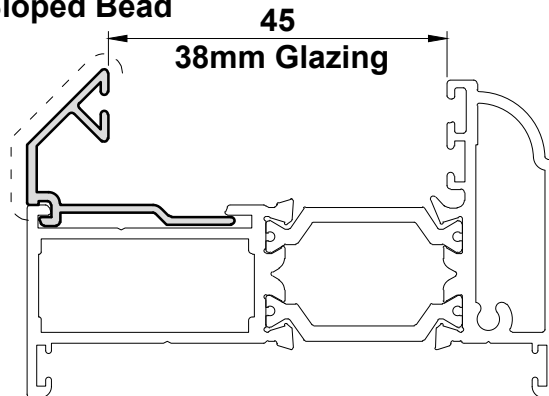


The beads shown here
is compatible with:

- | | | |
|--------|--------|--------|
| ETC610 | ETC620 | ETC630 |
| ETC611 | ETC622 | ETC631 |
| ETC612 | ETC625 | ETC632 |
| ETC613 | ETC627 | ETC634 |
| ETC614 | | ETC635 |
| ETC615 | | ETC636 |
| ETC616 | | ETC638 |
| ETC619 | | ETC645 |

ETC269

38mm Sloped Bead



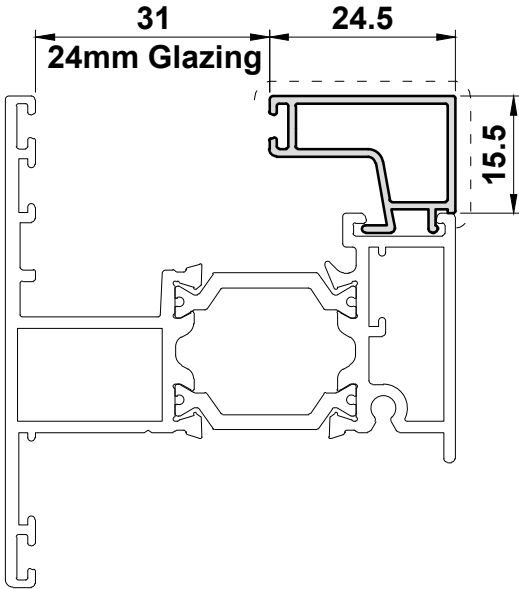
SCALE : 1:1

Primary Visible Side

Secondary Visible Side

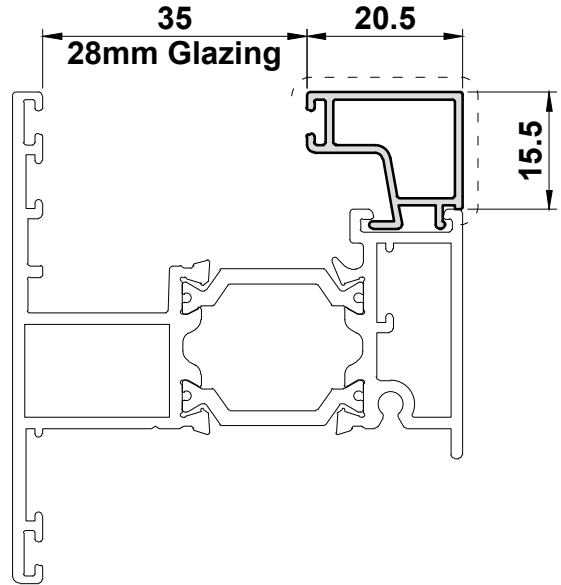
ETC270

24mm Square Bead



ETC272

28mm Square Bead

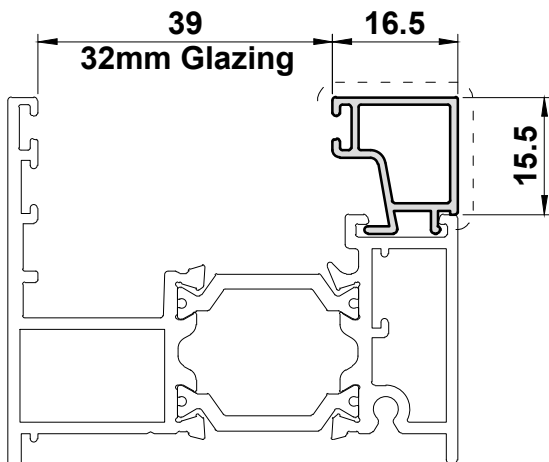


The Beads Shown here
are compatible with:

- ETC6101
- ETC623
- ETC624
- ETC628
- ETC6301
- ETC647

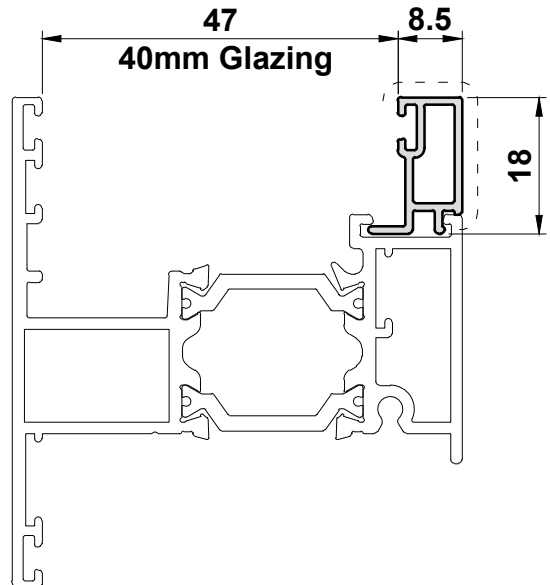
ETC267

32mm Square Bead



ETC667

40mm Square Bead



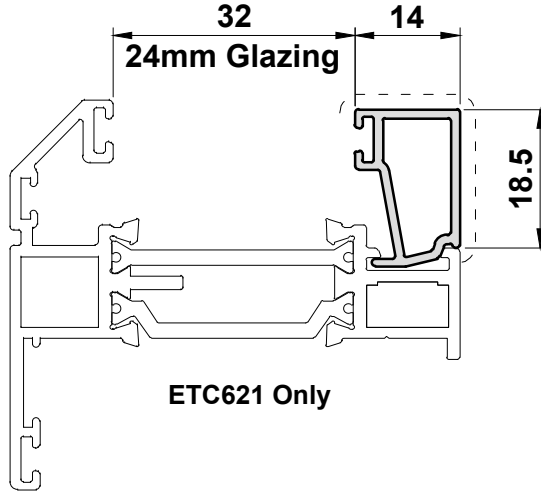
SCALE : 1:1

Primary Visible Side

Secondary Visible Side

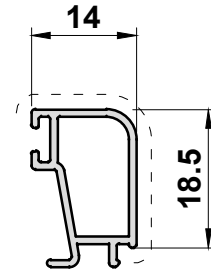
ETC369

24mm Square Bead



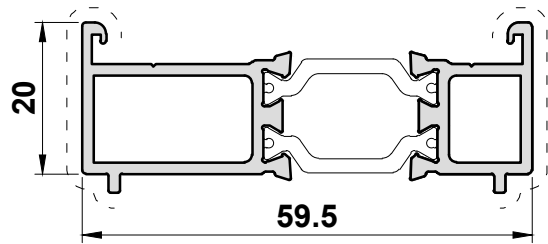
ETC273

24mm Curved Bead



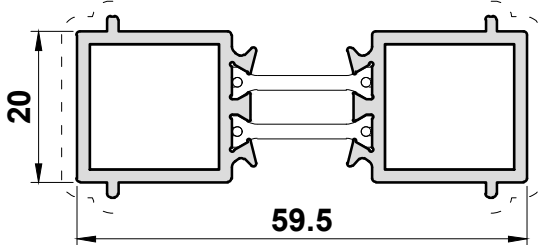
ETC557

20mm Frame Extension



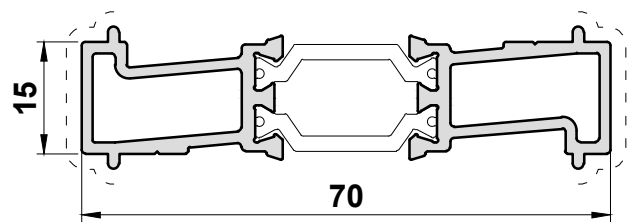
ETC553

20mm Frame Coupler



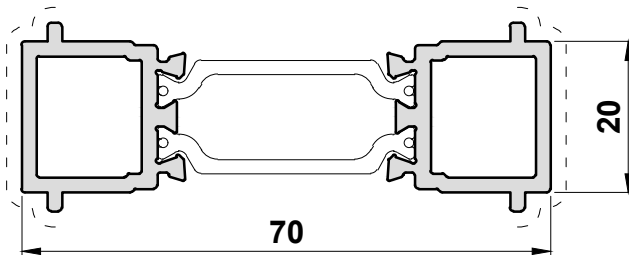
UN3000

Horizontal Coupler



ETC853

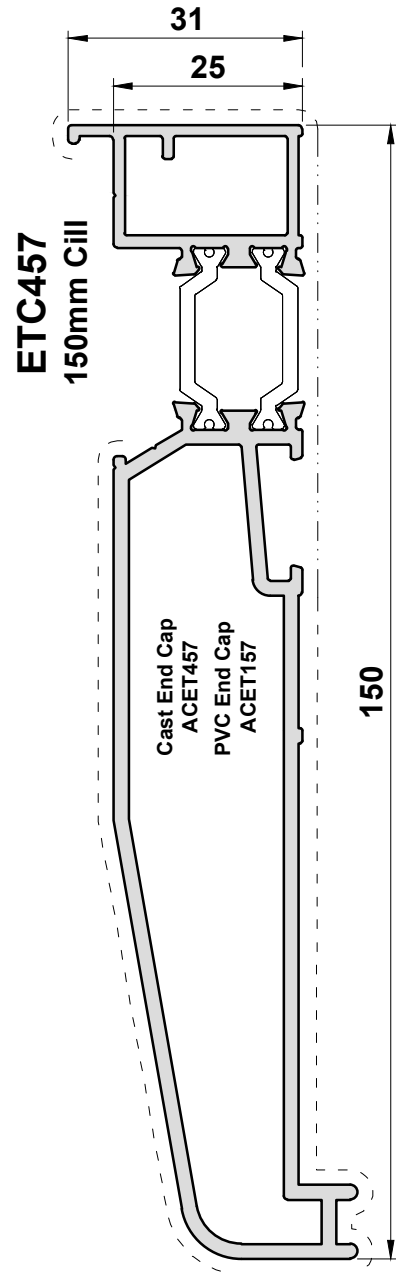
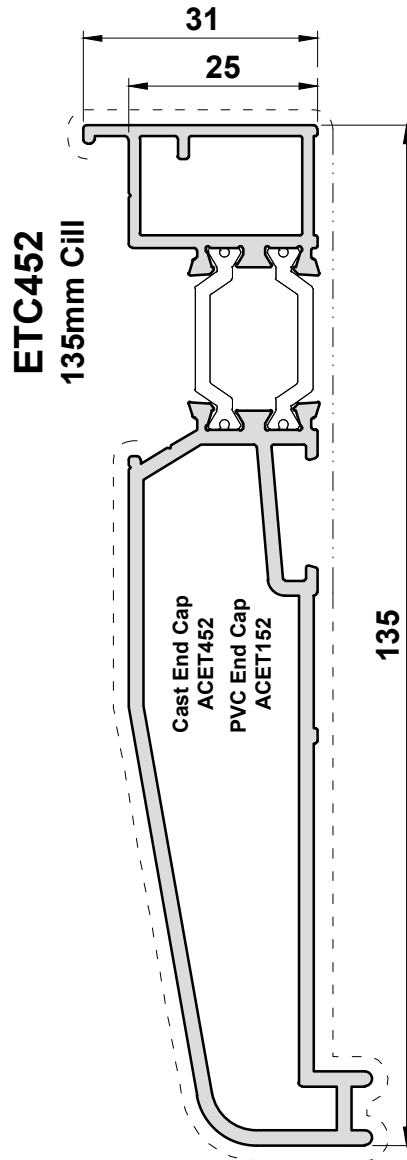
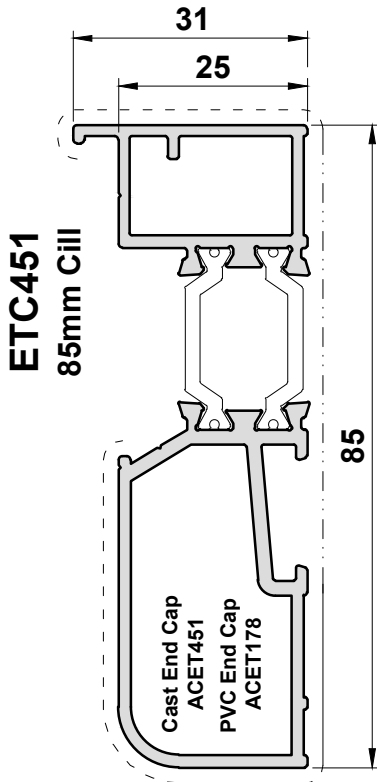
20mm Frame Coupler



SCALE : 1:1

Primary Visible Side

Secondary Visible Side

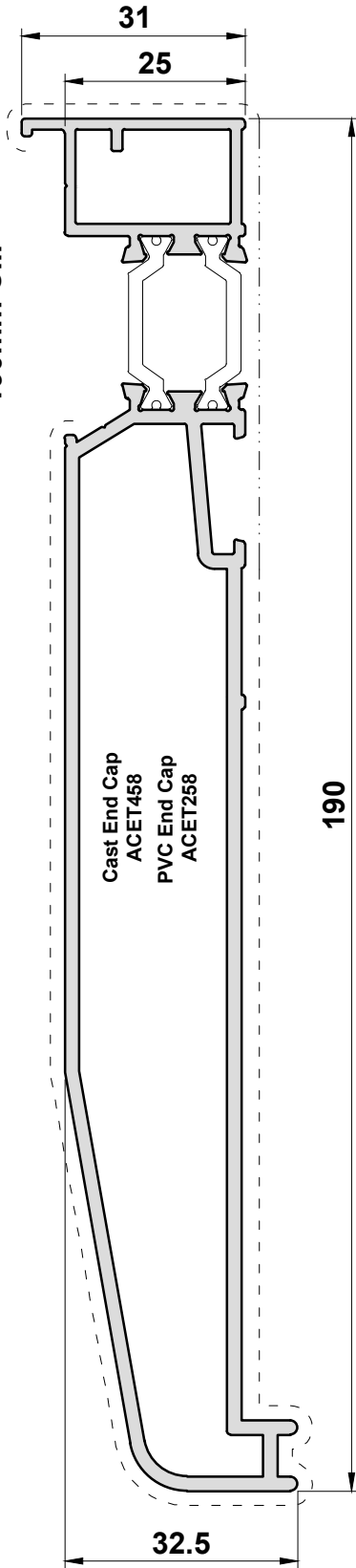


SCALE : 1:1

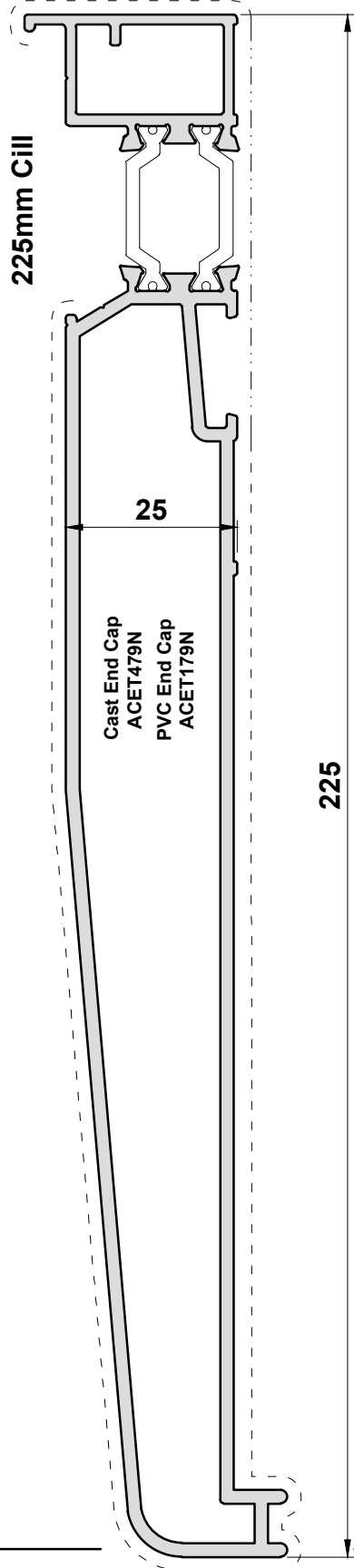
Primary Visible Side

Secondary Visible Side

ETC458
190mm Cill



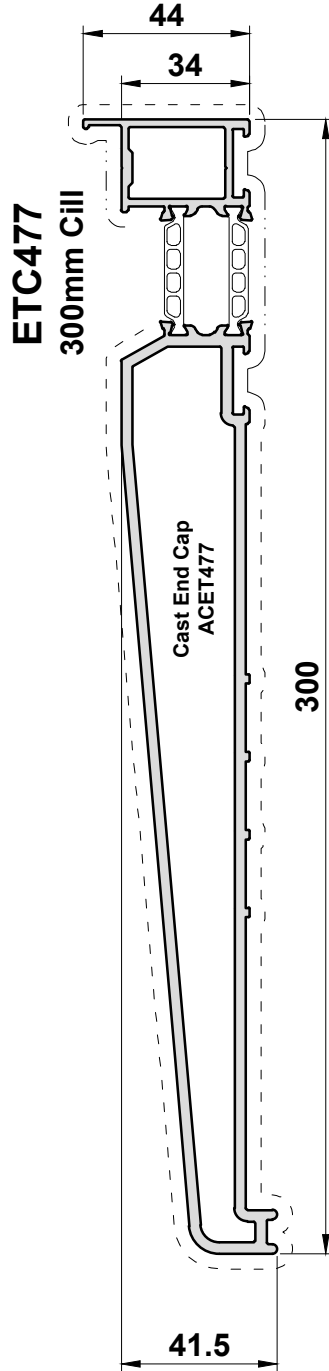
ETC479N
225mm Cill



SCALE : 1:1

Primary Visible Side

Secondary Visible Side

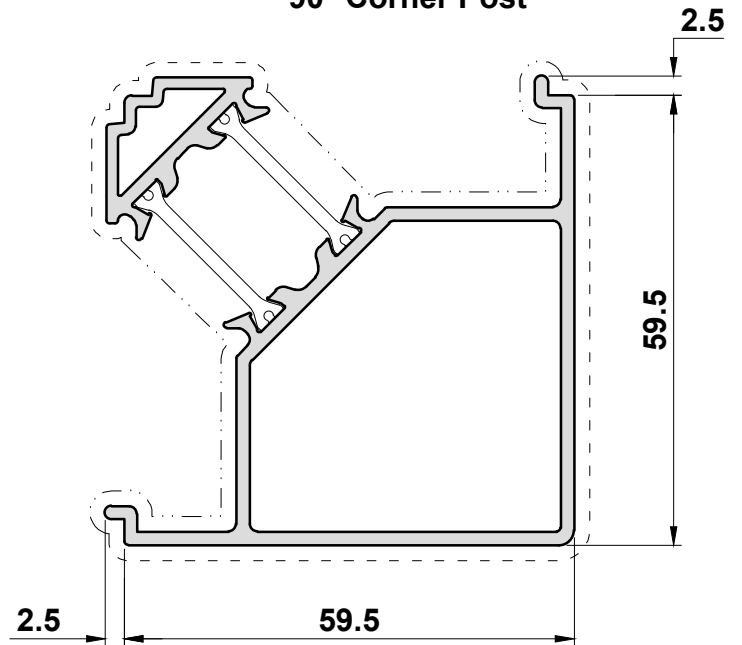


SCALE : 1:1

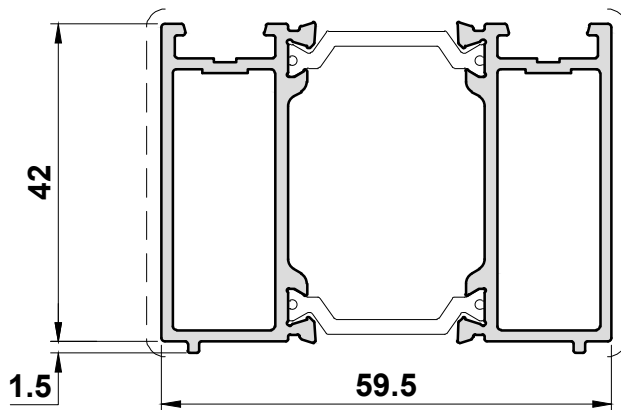
Primary Visible Side

Secondary Visible Side

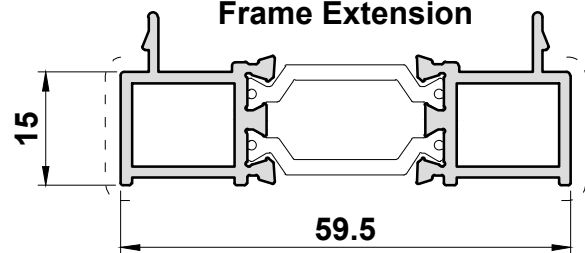
ETC655
90° Corner Post



ETC652
42mm Frame Extension



ETC660
Frame Extension



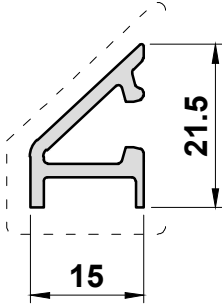
SCALE : 1:1

Primary Visible Side

Secondary Visible Side

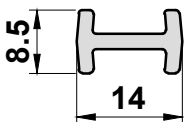
VL72

Weather Drip



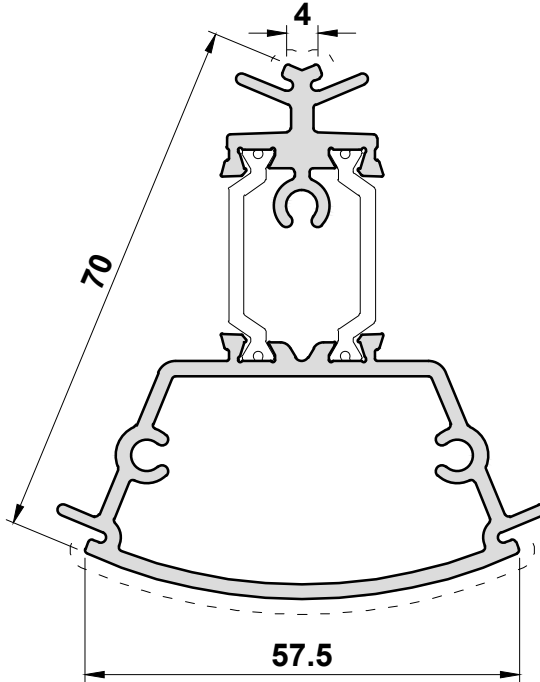
VL75

Coupling Clip



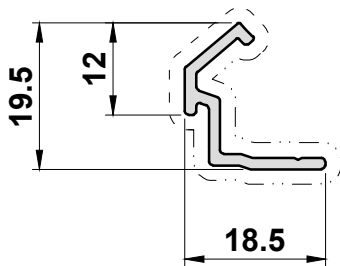
ETC385

135° Fixed Bay Pole



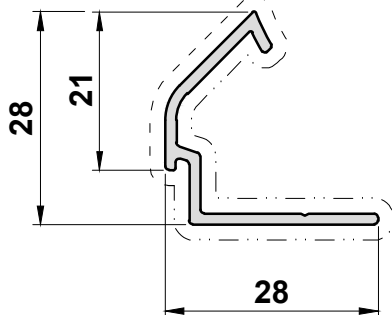
ETC650

Bay Pole Adaptor



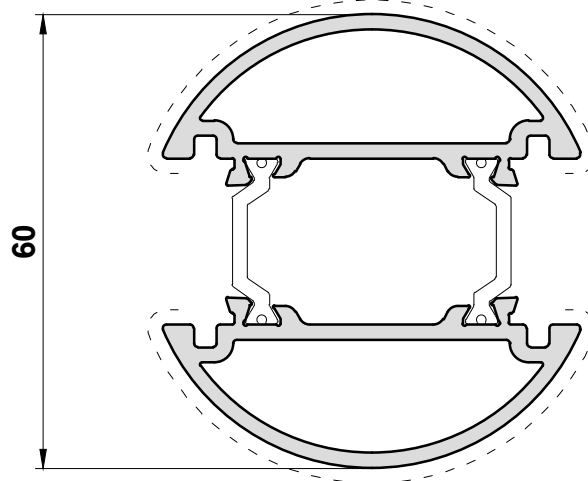
ETC651

Bay Pole Adaptor



ETC869

60mm Dia Bay Pole

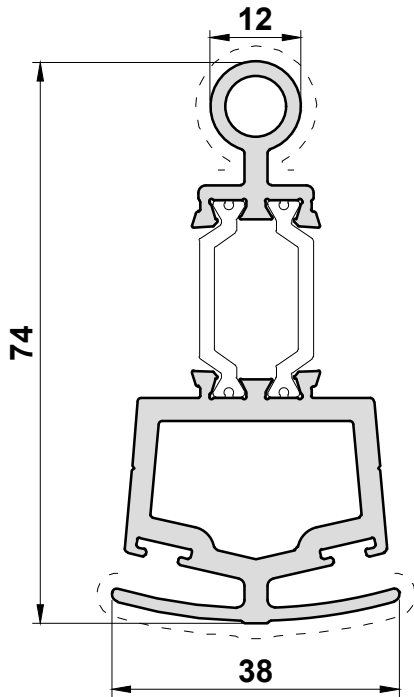


SCALE : 1:1

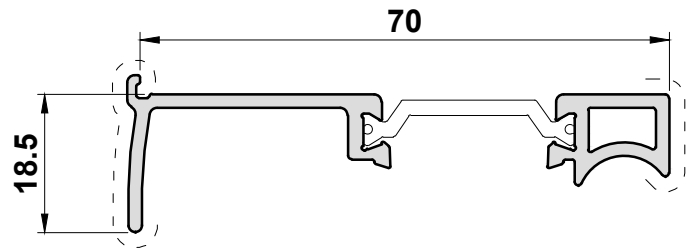
Primary Visible Side

Secondary Visible Side

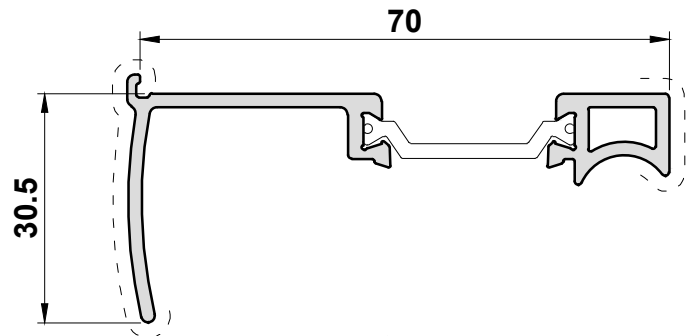
ETC080
Bay Pole



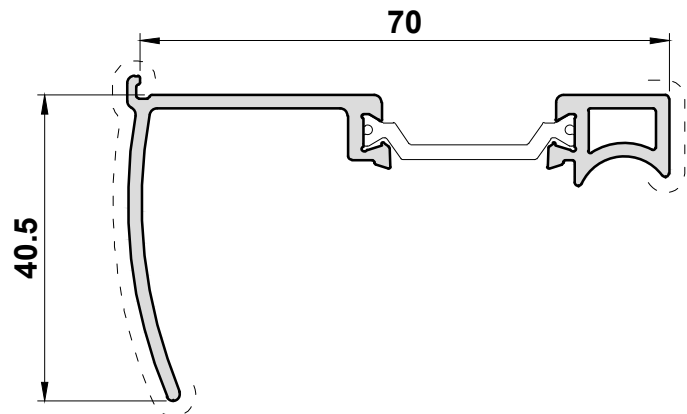
ETC081
169° - 150°
Bay Pole Adaptor



ETC082
149° - 130°
Bay Pole Adaptor



ETC083
129° - 115°
Bay Pole Adaptor



SCALE : 1:1

Primary Visible Side

Secondary Visible Side

SCALE : 1:1

Section B

Accessories

Photos & Drawings

Section B

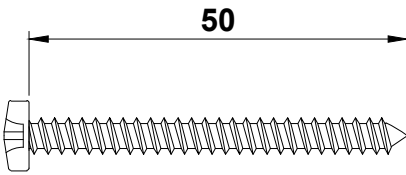
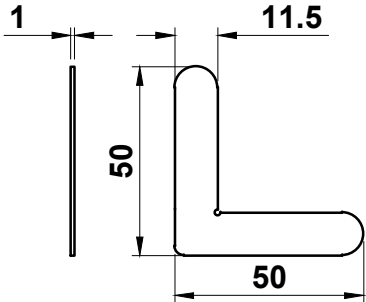
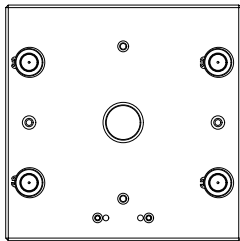
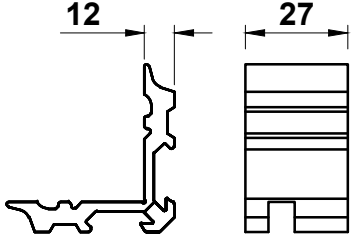
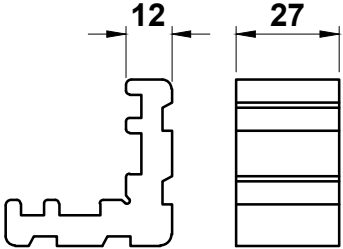
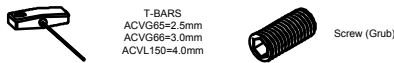

Image	Part Code	Pack	Unit	Application	Colour
	ACDR052 No. 10 x 50 S/S Self Tapping Pan Head Screw	200	pack	ETC048 ETC655	MF SA KL HP SSC SMC W Z PC
	ACDV21 Stainless Steel Chevron	100	pack	ETC621	MF SA KL HP SSC SMC W Z PC
	ACDV916 Bead Punch Tool	1	each	ETC640 ETC640G	MF SA KL HP SSC SMC W Z PC
	ACET011 Mechanical Corner Cleat	24	pack	ETC610 ETC6105 ETC611 ETC612 ETC613 ETC614 ETC616 ETC618 ETC619 ETC620 ETC622 ETC623 ETC625 ETC627	MF SA KL HP SSC SMC W Z PC
	ACET014 Crimping Corner Cleat	24	pack	ETC610 ETC6105 ETC611 ETC612 ETC613 ETC614 ETC616 ETC618 ETC619 ETC620 ETC622 ETC623 ETC625 ETC627	MF SA KL HP SSC SMC W Z PC
 <p>T-BARS ACVG65=2.5mm ACVG66=3.0mm ACVL150=4.0mm</p> <p>Screw (Grub)</p>	MF = Mill Finish SA = Silver Anodised KL = Basic Colour HP = Special Colour SSC = Smooth Satin Chrome SMC = Smokey Chrome PC = Polished Chrome	W = White Z = Black			

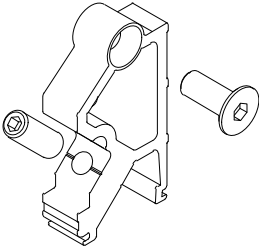
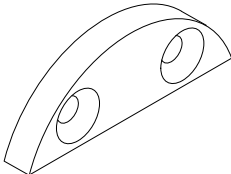
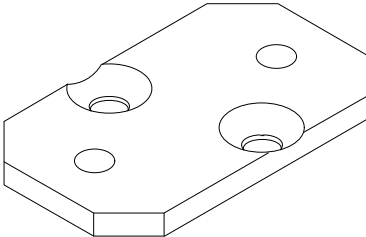
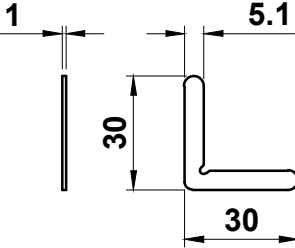
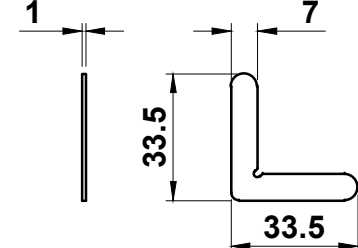

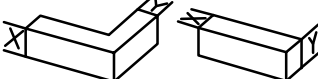
Image	Part Code	Pack	Unit	Application	Colour
	ACET016 Mechanical Transom Cleat	24	pack	ETC631 ETC635 ETC633 ETC636 ETC638	MF SA KL HP SSC SMC W Z PC
	ACET041 Cill Nose Bracket Screws = ACET067	1	each	ETC451 ETC452 ETC457 ETC458 ETC479N	MF SA KL HP SSC SMC W Z PC
	ACET043 Cruciform Fixing Plate	5	pack	ETC630	MF SA KL HP SSC SMC W Z PC
	ACET044 Stainless Steel Chevron	100	pack	ETC610 ETC611 ETC612 ETC613 ETC614 ETC616 ETC618 ETC619 ETC620 ETC621 ETC622 ETC625 ETC627 ETC645	MF SA KL HP SSC SMC W Z PC
	ACET045 Stainless Steel Chevron	100	pack	ETC613 ETC615 ETC616 ETC624 ETC628 ETC629 ETC647	MF SA KL HP SSC SMC W Z PC
	<p>T-BARS ACVG685=2.5mm ACVG666=3.0mm ACVL150=4.0mm</p> <p>Screw (Grub)</p>				
	<p>MF = Mill Finish SA = Silver Anodised KL = Basic Colour HP = Special Colour SSC = Smooth Satin Chrome SMC = Smokey Chrome PC = Polished Chrome</p>				
					<p>W = White Z = Black</p> 

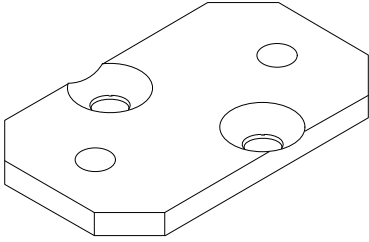
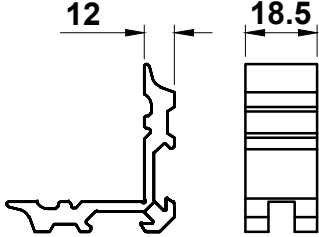
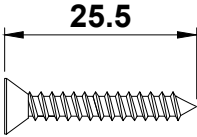
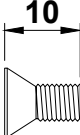
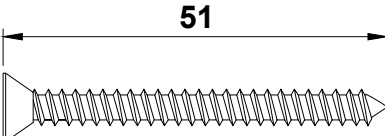


Image	Part Code	Pack	Unit	Application	Colour
	ACET051 Cruciform Fixing Plate	1	each	ETC632	MF
					SA
					KL
					HP
					SSC
					SMC
					W
					Z
					PC
					
SA					
KL					
HP					
SSC					
SMC					
W					
Z					
PC					
	ACET060 7 x 1" S/S Self Tapping CSK Screw	100	pack		
					SA
					KL
					HP
					SSC
					SMC
					W
					Z
					PC
					
SA					
KL					
HP					
SSC					
SMC					
W					
Z					
PC					
	ACET062 No. 10 x 50 S/S Self Tapping CSK Screw	100	pack		
					SA
					KL
					HP
					SSC
					SMC
					W
					Z
					PC
					 <p>T-BARS ACVG65=2.5mm ACVG66=3.0mm ACVL150=4.0mm</p>  <p>Screw (Grub)</p>

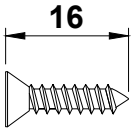
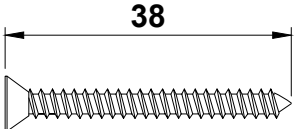
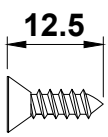

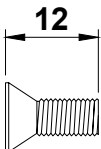


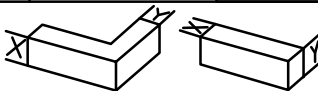
Image	Part Code	Pack	Unit	Application	Colour
	ACET064 No. 8 x 16 S/S Self Tapping Flange Screw	100	pack	Friction Hinges	MF
					SA
					KL
					HP
					SSC
					SMC
					W
					Z
					PC
	ACET066 No. 7 x 38 S/S Self Tapping CSK Screw	100	pack		MF
					SA
					KL
					HP
					SSC
					SMC
					W
					Z
					PC
	ACET067 No. 7 x 13 S/S Self Tapping CSK Screw	100	pack		MF
					SA
					KL
					HP
					SSC
					SMC
					W
					Z
					PC
	ACET068 No. 8 x 10 S/S Self Tapping Flange Screw	100	pack	Friction Hinges	MF
					SA
					KL
					HP
					SSC
					SMC
					W
					Z
					PC
	ACET069 M5 x 12 S/S CSK Machine Screw	100	pack		MF
					SA
					KL
					HP
					SSC
					SMC
					W
					Z
					PC
 T-BARS ACVG65=2.5mm ACVG66=3.0mm ACVL150=4.0mm	 Screw (Grub)	MF = Mill Finish SA = Silver Anodised KL = Basic Colour HP = Special Colour SSC = Smooth Satin Chrome SMC = Smokey Chrome PC = Polished Chrome	W = White Z = Black		

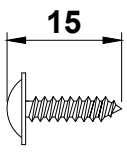

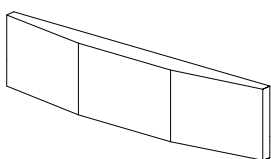
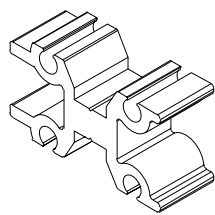
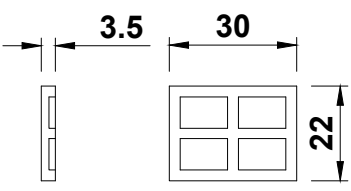

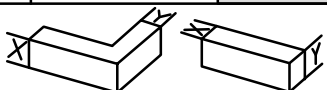
Image	Part Code	Pack	Unit	Application	Colour	
	ACET070 No. 8 x 13 S/S Self Tapping Flange Screw	100	pack	Friction Hinges	MF	
					SA	
					KL	
					HP	
					SSC	
					SMC	
					W	
					Z	
					PC	
	ACET080 Cockspur Handle	1	each	ACET083	MF	
					SA	✓
					KL	
					HP	
					SSC	
					SMC	✓
					W	✓
					Z	✓
					PC	
	ACET083 3mm Wedge	100	pack	ACET080	MF	
					SA	
					KL	
					HP	
					SSC	
					SMC	
					W	✓
					Z	✓
					PC	
	ACET090 Fixing Block	24	pack	ETC631 ETC635 ETC636 ETC638	MF	
					SA	
					KL	
					HP	
					SSC	
					SMC	
					W	
					Z	
					PC	
	ACET092 30 x 22.5 x 3.5 Packer	25	pack	ETC647	MF	
					SA	
					KL	
					HP	
					SSC	
					SMC	
					W	✓
					Z	✓
					PC	
 <p>T-BARS ACVG66=2.5mm ACVG66=3.0mm ACVL150=4.0mm</p> <p>Screw (Grub)</p>	MF = Mill Finish SA = Silver Anodised KL = Basic Colour HP = Special Colour SSC = Smooth Satin Chrome SMC = Smokey Chrome PC = Polished Chrome	W = White Z = Black				

Image	Part Code	Pack	Unit	Application	Colour
	ACET094 End Caps	10	pack	ETC635	MF SA KL HP SSC SMC W Z PC
	ACET099 No. 8 x 19 S/S Self Tapping Flange Screw	100	pack	Friction Hinges	MF SA KL HP SSC SMC W Z PC
	ACET122 M4 x 10mm C/S Screw	100	pack		MF SA KL HP SSC SMC W Z PC
	ACET130 Galvanised Steel Fixing Strap 200mm x 25mm x 1.5mm	100	pack	ETC611 ETC612 ETC614 ETC615 ETC619	MF SA KL HP SSC SMC W Z PC
	ACET131 Drainage Cover Cap For colour matched drainage caps see ACET431	100	pack		MF SA KL HP SSC SMC W ✓ Z ✓ PC
<p>T-BARS ACVG65=2.5mm ACVG66=3.0mm ACVL150=4.0mm</p> <p>Screw (Grub)</p>	MF = Mill Finish SA = Silver Anodised KL = Basic Colour HP = Special Colour SSC = Smooth Satin Chrome SMC = Smokey Chrome PC = Polished Chrome	W = White Z = Black			

Image	Part Code	Pack	Unit	Application	Colour	
	ACET136 Crimping Cleat	24	pack	ETC6101 ETC624 ETC628 ETC629	MF	
					SA	
					KL	
					HP	
					SSC	
					SMC	
					W	
					Z	
					PC	
						ACET152 Cill End Caps
SA						
KL						
HP						
SSC						
SMC						
W	✓					
Z	✓					
PC						
	ACET157 Cill End Caps	10	pair	ETC457		
					SA	
					KL	
					HP	
					SSC	
					SMC	
					W	✓
					Z	✓
					PC	
						ACET165 Espagnolette Handle 9mm Spindle
SA	✓					
KL						
HP						
SSC						
SMC						
W	✓					
Z	✓					
PC						
	ACET178 Cill End Caps	10	pair	ETC451		
					SA	
					KL	
					HP	
					SSC	
					SMC	
					W	✓
					Z	✓
					PC	
					 T-BARS ACVG66=2.5mm ACVG66=3.0mm ACVL150=4.0mm Screw (Grub)	MF = Mill Finish SA = Silver Anodised KL = Basic Colour HP = Special Colour SSC = Smooth Satin Chrome SMC = Smokey Chrome PC = Polished Chrome

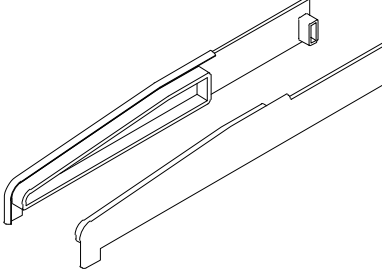
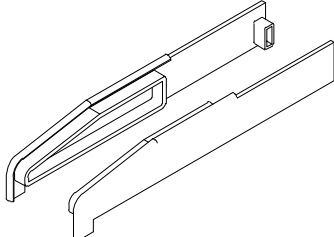
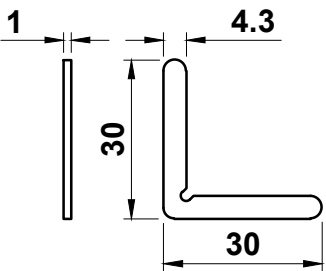
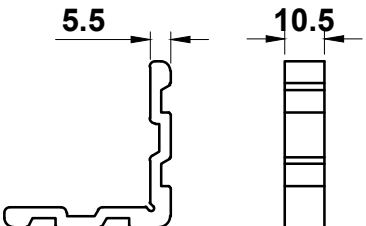
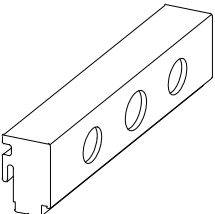

Image	Part Code	Pack	Unit	Application	Colour	
	ACET479N Cill End Caps	10	pair	ETC479N	MF	
					SA	
					KL	
					HP	
					SSC	
					SMC	
					W	✓
					Z	✓
					PC	
						ACET258 Cill End Caps
SA						
KL						
HP						
SSC						
SMC						
W	✓					
Z	✓					
PC						
	ACET311 Stainless Steel Chevron	50	pack	ETC6105		
					SA	
					KL	
					HP	
					SSC	
					SMC	
					W	
					Z	
					PC	
						ACET323 Crimping Cleat (inner chamber)
SA						
KL						
HP						
SSC						
SMC						
W						
Z						
PC						
	ACET365 Espag. Handle Fixing Block (94mm)	1	each	ACET165 ETC621 ETC273 ETC367		
					SA	✓
					KL	✓
					HP	✓
					SSC	
					SMC	
					W	✓
					Z	✓
					PC	
					 <p>T-BARS ACVG65=2.5mm ACVG66=3.0mm ACVL150=4.0mm</p> <p>Screw (Grub)</p>	MF = Mill Finish SA = Silver Anodised KL = Basic Colour HP = Special Colour SSC = Smooth Satin Chrome SMC = Smokey Chrome PC = Polished Chrome

Image	Part Code	Pack	Unit	Application	Colour
	ACET366 Cockspur Handle Fixing Block (94mm)	1	each	ACET165 ETC621 ETC273 ETC367	MF
					SA
					KL
					HP
					SSC
					SMC
					W
					Z
					PC
					PC
	ACET367 Curved Espag. Handle Fixing Block (94mm)	1	each	ACET165 ETC621 ETC273 ETC367	MF
					SA
					KL
					HP
					SSC
					SMC
					W
					Z
					PC
					PC
	ACET368 Curved Cockspur Handle Fixing Block (94mm)	1	each	ACET165 ETC621 ETC273 ETC367	MF
					SA
					KL
					HP
					SSC
					SMC
					W
					Z
					PC
					PC
	ACET390 25mm Polyamide Screw	200	pack		MF
					SA
					KL
					HP
					SSC
					SMC
					W
					Z
					PC
					PC
	ACET4036 Anti-Twist Clip	100	pack	ETC6305 ETC6306	MF
					SA
					KL
					HP
					SSC
					SMC
					W
					Z
					PC
					PC
<p>T-BARS ACVG66=2.5mm ACVG66=3.0mm ACVL150=4.0mm</p> <p>Screw (Grub)</p>	MF = Mill Finish SA = Silver Anodised KL = Basic Colour HP = Special Colour SSC = Smooth Satin Chrome SMC = Smokey Chrome PC = Polished Chrome	W = White Z = Black			

Image	Part Code	Pack	Unit	Application	Colour																		
	ACET421N Crimping Cleat (Inner Chamber)	1	each	ETC6105	<table border="1"> <tr><td>MF</td><td>✓</td></tr> <tr><td>SA</td><td></td></tr> <tr><td>KL</td><td></td></tr> <tr><td>HP</td><td></td></tr> <tr><td>SSC</td><td></td></tr> <tr><td>SMC</td><td></td></tr> <tr><td>W</td><td></td></tr> <tr><td>Z</td><td></td></tr> <tr><td>PC</td><td></td></tr> </table>	MF	✓	SA		KL		HP		SSC		SMC		W		Z		PC	
MF	✓																						
SA																							
KL																							
HP																							
SSC																							
SMC																							
W																							
Z																							
PC																							
	ACET431 Colour Match Drainage Cover Cap	8	pack		<table border="1"> <tr><td>MF</td><td></td></tr> <tr><td>SA</td><td></td></tr> <tr><td>KL</td><td>✓</td></tr> <tr><td>HP</td><td>✓</td></tr> <tr><td>SSC</td><td></td></tr> <tr><td>SMC</td><td></td></tr> <tr><td>W</td><td></td></tr> <tr><td>Z</td><td></td></tr> <tr><td>PC</td><td></td></tr> </table>	MF		SA		KL	✓	HP	✓	SSC		SMC		W		Z		PC	
MF																							
SA																							
KL	✓																						
HP	✓																						
SSC																							
SMC																							
W																							
Z																							
PC																							
	ACET440 Variable Cill Angle Bracket	1	each	ETC451 ETC452 ETC457 ETC458 ETC479N	<table border="1"> <tr><td>MF</td><td>✓</td></tr> <tr><td>SA</td><td></td></tr> <tr><td>KL</td><td></td></tr> <tr><td>HP</td><td></td></tr> <tr><td>SSC</td><td></td></tr> <tr><td>SMC</td><td></td></tr> <tr><td>W</td><td></td></tr> <tr><td>Z</td><td></td></tr> <tr><td>PC</td><td></td></tr> </table>	MF	✓	SA		KL		HP		SSC		SMC		W		Z		PC	
MF	✓																						
SA																							
KL																							
HP																							
SSC																							
SMC																							
W																							
Z																							
PC																							
	ACET451 Cast Cill End Caps	1	pair	ETC451	<table border="1"> <tr><td>MF</td><td>✓</td></tr> <tr><td>SA</td><td></td></tr> <tr><td>KL</td><td>✓</td></tr> <tr><td>HP</td><td>✓</td></tr> <tr><td>SSC</td><td></td></tr> <tr><td>SMC</td><td></td></tr> <tr><td>W</td><td>✓</td></tr> <tr><td>Z</td><td>✓</td></tr> <tr><td>PC</td><td></td></tr> </table>	MF	✓	SA		KL	✓	HP	✓	SSC		SMC		W	✓	Z	✓	PC	
MF	✓																						
SA																							
KL	✓																						
HP	✓																						
SSC																							
SMC																							
W	✓																						
Z	✓																						
PC																							
	ACET452 Cast Cill End Caps	1	pair	ETC452	<table border="1"> <tr><td>MF</td><td>✓</td></tr> <tr><td>SA</td><td></td></tr> <tr><td>KL</td><td>✓</td></tr> <tr><td>HP</td><td>✓</td></tr> <tr><td>SSC</td><td></td></tr> <tr><td>SMC</td><td></td></tr> <tr><td>W</td><td>✓</td></tr> <tr><td>Z</td><td>✓</td></tr> <tr><td>PC</td><td></td></tr> </table>	MF	✓	SA		KL	✓	HP	✓	SSC		SMC		W	✓	Z	✓	PC	
MF	✓																						
SA																							
KL	✓																						
HP	✓																						
SSC																							
SMC																							
W	✓																						
Z	✓																						
PC																							
<p>T-BARS ACVG65=2.5mm ACVG66=3.0mm ACVL150=4.0mm</p> <p>Screw (Grub)</p>	MF = Mill Finish SA = Silver Anodised KL = Basic Colour HP = Special Colour SSC = Smooth Satin Chrome SMC = Smokey Chrome PC = Polished Chrome	W = White Z = Black																					

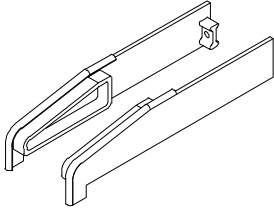
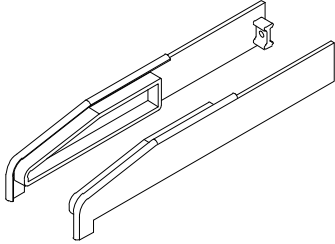


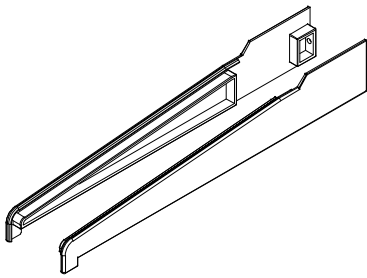



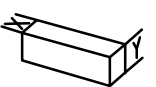
Image	Part Code	Pack	Unit	Application	Colour	
	ACET457 Cast Cill End Caps	1	pair	ETC457	MF	✓
					SA	
					KL	✓
					HP	✓
					SSC	
					SMC	
					W	✓
					Z	✓
					PC	
	ACET458 Cast Cill End Caps	1	pair	ETC458	MF	✓
					SA	
					KL	✓
					HP	✓
					SSC	
					SMC	
					W	✓
					Z	✓
					PC	
	ACET460 Inline Espag Handle with 9mm Spindle	1	each	ACET601 ACET602 ACET603 ACET604 ACET605	MF	
					SA	
					KL	✓
					HP	✓
					SSC	✓
					SMC	✓
					W	✓
					Z	✓
					PC	✓
	ACET465 L/R Cranked Espag Handle with 9mm Spindle	1	each	ACET601 ACET602 ACET603 ACET604 ACET605	MF	
					SA	
					KL	✓
					HP	✓
					SSC	✓
					SMC	✓
					W	✓
					Z	✓
					PC	✓
	ACET477 Cast End Cap	1	pair	ETC477	MF	✓
					SA	
					KL	✓
					HP	✓
					SSC	
					SMC	
					W	✓
					Z	✓
					PC	
 <small>T-BARS ACVG66=2.5mm ACVG66=3.0mm ACVL150=4.0mm</small>	 <small>Screw (Grub)</small>	MF = Mill Finish SA = Silver Anodised KL = Basic Colour HP = Special Colour SSC = Smooth Satin Chrome SMC = Smokey Chrome PC = Polished Chrome	W = White Z = Black	 		

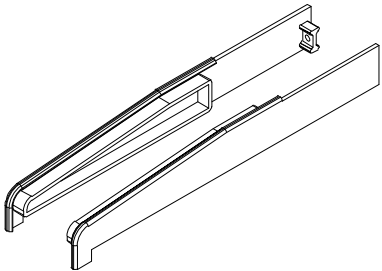
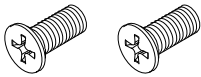
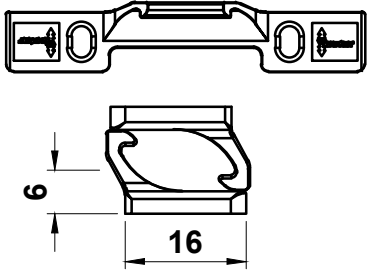
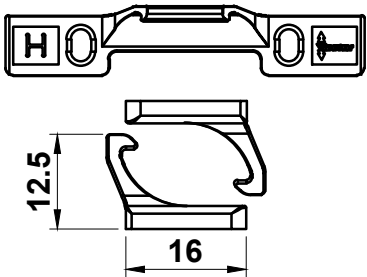
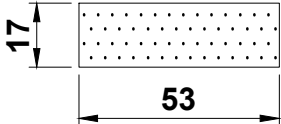



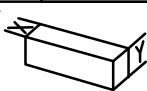
Image	Part Code	Pack	Unit	Application	Colour																		
	ACET479N Cast Cill End Caps	1	pair	ETC479N	<table border="1"> <tr><td>MF</td><td>✓</td></tr> <tr><td>SA</td><td></td></tr> <tr><td>KL</td><td>✓</td></tr> <tr><td>HP</td><td>✓</td></tr> <tr><td>SSC</td><td></td></tr> <tr><td>SMC</td><td></td></tr> <tr><td>W</td><td>✓</td></tr> <tr><td>Z</td><td>✓</td></tr> <tr><td>PC</td><td></td></tr> </table>	MF	✓	SA		KL	✓	HP	✓	SSC		SMC		W	✓	Z	✓	PC	
MF	✓																						
SA																							
KL	✓																						
HP	✓																						
SSC																							
SMC																							
W	✓																						
Z	✓																						
PC																							
	ACET495 Handle Fixing Kit <u>1 pack contains:</u> 2no M5 x 12 S/S CSK Machine Screw	1	pack	ACET460 ACET465	<table border="1"> <tr><td>MF</td><td></td></tr> <tr><td>SA</td><td></td></tr> <tr><td>KL</td><td></td></tr> <tr><td>HP</td><td></td></tr> <tr><td>SSC</td><td></td></tr> <tr><td>SMC</td><td></td></tr> <tr><td>W</td><td></td></tr> <tr><td>Z</td><td></td></tr> <tr><td>PC</td><td></td></tr> </table>	MF		SA		KL		HP		SSC		SMC		W		Z		PC	
MF																							
SA																							
KL																							
HP																							
SSC																							
SMC																							
W																							
Z																							
PC																							
	ACET513 13mm Cavity Hinge Protector 4 Per Set (2 pairs)	50	sets	ETC622	<table border="1"> <tr><td>MF</td><td></td></tr> <tr><td>SA</td><td></td></tr> <tr><td>KL</td><td></td></tr> <tr><td>HP</td><td></td></tr> <tr><td>SSC</td><td></td></tr> <tr><td>SMC</td><td></td></tr> <tr><td>W</td><td></td></tr> <tr><td>Z</td><td></td></tr> <tr><td>PC</td><td></td></tr> </table>	MF		SA		KL		HP		SSC		SMC		W		Z		PC	
MF																							
SA																							
KL																							
HP																							
SSC																							
SMC																							
W																							
Z																							
PC																							
	ACET516 16mm Cavity Hinge Protector 4 Per Set (2 pairs)	50	sets	ETC620 ETC621 ETC623 ETC624 ETC625	<table border="1"> <tr><td>MF</td><td></td></tr> <tr><td>SA</td><td></td></tr> <tr><td>KL</td><td></td></tr> <tr><td>HP</td><td></td></tr> <tr><td>SSC</td><td></td></tr> <tr><td>SMC</td><td></td></tr> <tr><td>W</td><td></td></tr> <tr><td>Z</td><td></td></tr> <tr><td>PC</td><td></td></tr> </table>	MF		SA		KL		HP		SSC		SMC		W		Z		PC	
MF																							
SA																							
KL																							
HP																							
SSC																							
SMC																							
W																							
Z																							
PC																							
	ACET610 Foam Infill 1250mm Lengths	1	each	ETC610	<table border="1"> <tr><td>MF</td><td></td></tr> <tr><td>SA</td><td></td></tr> <tr><td>KL</td><td></td></tr> <tr><td>HP</td><td></td></tr> <tr><td>SSC</td><td></td></tr> <tr><td>SMC</td><td></td></tr> <tr><td>W</td><td></td></tr> <tr><td>Z</td><td></td></tr> <tr><td>PC</td><td></td></tr> </table>	MF		SA		KL		HP		SSC		SMC		W		Z		PC	
MF																							
SA																							
KL																							
HP																							
SSC																							
SMC																							
W																							
Z																							
PC																							
 <p>T-BARS ACVG65=2.5mm ACVG66=3.0mm ACVL150=4.0mm</p>  <p>Screw (Grub)</p>	<p>MF = Mill Finish SA = Silver Anodised KL = Basic Colour HP = Special Colour SSC = Smooth Satin Chrome SMC = Smokey Chrome PC = Polished Chrome</p> <p>W = White Z = Black</p>	 																					

Image	Part Code	Pack	Unit	Application	Colour
	ACET615 Crimping Cleat (outer chamber)	24	pack	ETC615	MF SA KL HP SSC SMC W Z PC
	ACET616 Crimping Cleat (inner chamber)	24	pack	ETC615	MF SA KL HP SSC SMC W Z PC
	ACET618 Vari-angle Cleat	24	pack	ETC610 ETC6105 ETC611 ETC612 ETC613 ETC614 ETC616 ETC618 ETC619 ETC620 ETC622 ETC623 ETC625 ETC627	MF SA KL HP SSC SMC W Z PC
	ACET619 Foam Infill 1250mm Lengths	1	each	ETC614 ETC618 ETC619	MF SA KL HP SSC SMC W Z PC
	ACET621 Crimping Cleat (outer chamber)	24	pack	ETC621	MF SA KL HP SSC SMC W Z PC
<p>T-BARS ACVG65=2.5mm ACVG66=3.0mm ACVL150=4.0mm</p> <p>Screw (Grub)</p>	MF = Mill Finish SA = Silver Anodised KL = Basic Colour HP = Special Colour SSC = Smooth Satin Chrome SMC = Smokey Chrome PC = Polished Chrome	W = White Z = Black			

Image	Part Code	Pack	Unit	Application	Colour
	ACET624 Stainless Steel Chevron	100	pack	ETC624	MF SA KL HP SSC SMC W Z PC
	ACET625 Anti-Twist Clip	100	pack	ETC631 ETC632 ETC636	MF SA KL HP SSC SMC W Z PC
	ACET628 Crimping Cleat	24	pack	ETC628 ETC629	MF SA KL HP SSC SMC W Z PC
	ACET629 Crimping Cleat	24	pack	ETC628 ETC629	MF SA KL HP SSC SMC W Z PC
	ACET6301 Cruciform Bracket	10	pack	ETC6301	MF SA KL HP SSC SMC W Z PC
	MF = Mill Finish SA = Silver Anodised KL = Basic Colour HP = Special Colour SSC = Smooth Satin Chrome SMC = Smokey Chrome PC = Polished Chrome	W = White Z = Black			

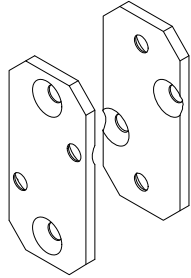
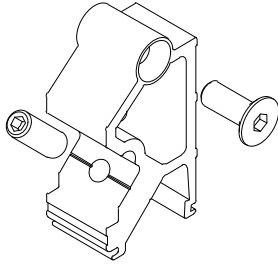
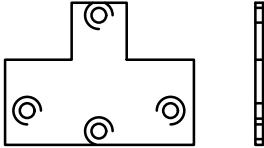
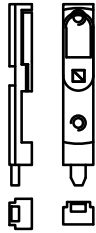
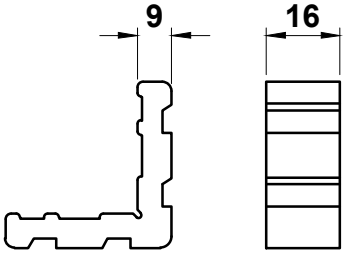


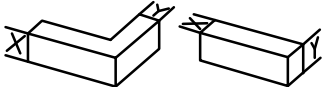
Image	Part Code	Pack	Unit	Application	Colour
	ACET6305 Cruciform Fixing Plate	5	pairs	ETC6305	MF
					SA
					KL
					HP
					SSC
					SMC
					W
					Z
					PC
	ACET6306 Mechanical Cruciform Cleat	10	pack	ETC6306	MF
					SA
					KL
					HP
					SSC
					SMC
					W
					Z
					PC
	ACET634 Cruciform Fixing Plate	10	pack	ETC634	MF
					SA
					KL
					HP
					SSC
					SMC
					W
					Z
					PC
	ACET645 Shoot Bolts	1	pair	ETC648	MF
					SA
					KL
					HP
					SSC
					SMC
					W
					Z
					PC
	ACET647 Crimping Cleat	24	pack	ETC647	MF
					SA
					KL
					HP
					SSC
					SMC
					W
					Z
					PC
 T-BARS ACVG65=2.5mm ACVG66=3.0mm ACVL150=4.0mm	 Screw (Grub)	MF = Mill Finish SA = Silver Anodised KL = Basic Colour HP = Special Colour SSC = Smooth Satin Chrome SMC = Smokey Chrome PC = Polished Chrome	W = White Z = Black		

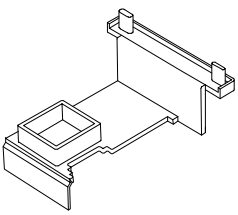
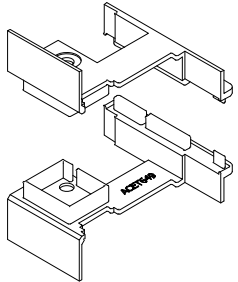
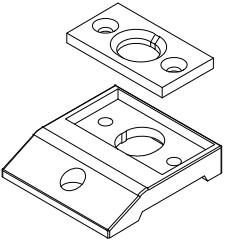
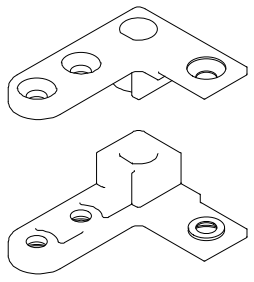
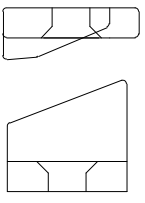


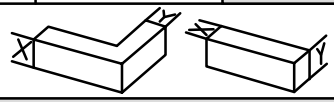
Image	Part Code	Pack	Unit	Application	Colour	
	ACET648 Meeting Stile End Cap	10	pair	ETC648	MF	
					SA	
					KL	
					HP	
					SSC	
					SMC	
					W	✓
					Z	✓
PC						
	ACET649 French Casement End Cap	1	pair	ETC649	MF	
					SA	
					KL	
					HP	
					SSC	
					SMC	
					W	✓
					Z	✓
PC						
	ACET650 French Casement Keep	1	kit	ACET649 ACET651 ETC649	MF	
					SA	
					KL	
					HP	
					SSC	
					SMC	
					W	
					Z	
PC						
	ACET651 Shoot bolt Guide	1	pair	ACET649 ACET651 ACET650 ETC649	MF	
					SA	
					KL	
					HP	
					SSC	
					SMC	
					W	
					Z	✓
PC						
	ACET652 Pull-In Blocks	50	pack	ETC620 ETC621 ETC623 ETC624 ETC625 ETC627 ETC628	MF	
					SA	
					KL	
					HP	
					SSC	
					SMC	
					W	
					Z	
PC						
 <p>T-BARS ACVG65=2.5mm ACVG66=3.0mm ACVL150=4.0mm</p>  <p>Screw (Grub)</p>	MF = Mill Finish SA = Silver Anodised KL = Basic Colour HP = Special Colour SSC = Smooth Satin Chrome SMC = Smokey Chrome PC = Polished Chrome	W = White Z = Black				

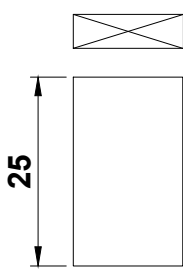
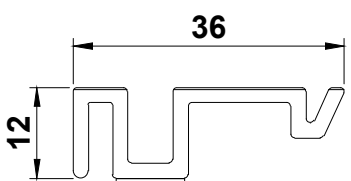
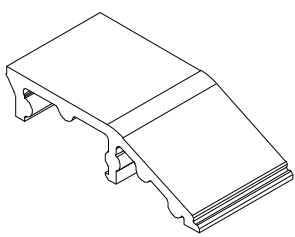
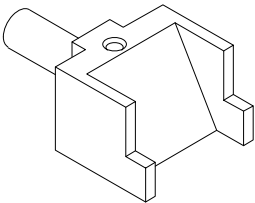

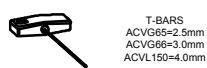

Image	Part Code	Pack	Unit	Application	Colour	
	ACET653 25mm Infill	12	pack	ETC648 ETC649	MF	
					SA	
					KL	
					HP	
					SSC	
					SMC	
					W	
					Z	
					PC	
						ACET657 Bridge Packer
SA						
KL						
HP						
SSC						
SMC						
W						
Z						
PC						
	ACET680 Riser Block	100	pack	ETC611 ETC612 ETC614 ETC615 ETC618 ETC619		
					SA	
					KL	
					HP	
					SSC	
					SMC	
					W	✓
					Z	✓
					PC	
						ACET690 Punch for ETC628
SA						
KL						
HP						
SSC						
SMC						
W						
Z						
PC						
	ACET691 V Block for ETC628	1	each	ETC628 ETC629		
					SA	
					KL	
					HP	
					SSC	
					SMC	
					W	
					Z	
					PC	
					 	MF = Mill Finish SA = Silver Anodised KL = Basic Colour HP = Special Colour SSC = Smooth Satin Chrome SMC = Smokey Chrome PC = Polished Chrome

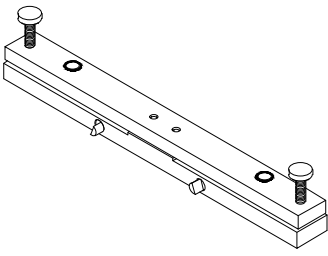
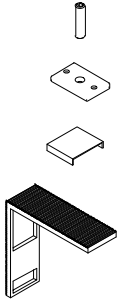
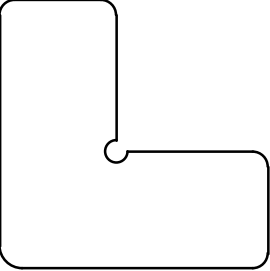
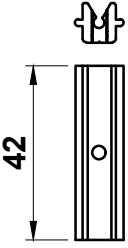
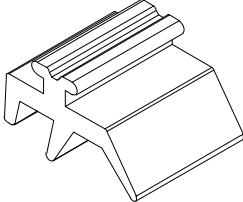
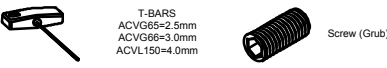
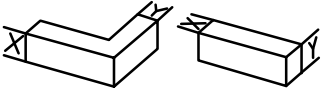
Image	Part Code	Pack	Unit	Application	Colour
	ACET692 Drilling Jig for ACET618 Vari-Angle Cleat	1	each	ACET618	MF <input checked="" type="checkbox"/> SA <input type="checkbox"/> KL <input type="checkbox"/> HP <input type="checkbox"/> SSC <input type="checkbox"/> SMC <input type="checkbox"/> W <input type="checkbox"/> Z <input type="checkbox"/> PC <input type="checkbox"/>
	ACET695 Glass Adjuster Kit	1	kit	ETC624 ETC628 ETC629	MF <input type="checkbox"/> SA <input type="checkbox"/> KL <input type="checkbox"/> HP <input type="checkbox"/> SSC <input type="checkbox"/> SMC <input type="checkbox"/> W <input type="checkbox"/> Z <input type="checkbox"/> PC <input type="checkbox"/>
	ACET827 Chevron	100	pack		MF <input type="checkbox"/> SA <input type="checkbox"/> KL <input type="checkbox"/> HP <input type="checkbox"/> SSC <input type="checkbox"/> SMC <input type="checkbox"/> W <input type="checkbox"/> Z <input type="checkbox"/> PC <input type="checkbox"/>
	ACET832 Transom bracket	10	pack	ETC634	MF <input type="checkbox"/> SA <input type="checkbox"/> KL <input type="checkbox"/> HP <input type="checkbox"/> SSC <input type="checkbox"/> SMC <input type="checkbox"/> W <input type="checkbox"/> Z <input type="checkbox"/> PC <input type="checkbox"/>
	ACET835 4mm External Captive Gasket	200	m		MF <input type="checkbox"/> SA <input type="checkbox"/> KL <input type="checkbox"/> HP <input type="checkbox"/> SSC <input type="checkbox"/> SMC <input type="checkbox"/> W <input type="checkbox"/> Z <input checked="" type="checkbox"/> PC <input type="checkbox"/>
	MF = Mill Finish SA = Silver Anodised KL = Basic Colour HP = Special Colour SSC = Smooth Satin Chrome SMC = Smokey Chrome PC = Polished Chrome	W = White Z = Black			

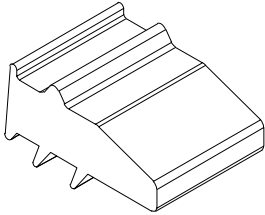
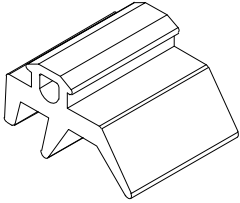
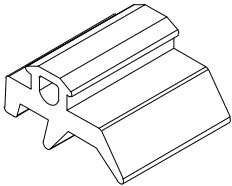
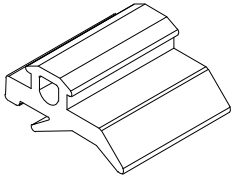



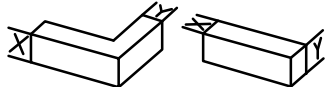
Image	Part Code	Pack	Unit	Application	Colour	
	ACET840 5mm Low Line Wedge	150	m		MF	
					SA	
					KL	
					HP	
					SSC	
					SMC	
					W	✓
					Z	
					PC	
	ACET841 4mm Low Line External Gasket	200	m		MF	
					SA	
					KL	
					HP	
					SSC	
					SMC	
					W	✓
					Z	
					PC	
	ACET842 3mm Low Line External Gasket	200	m		MF	
					SA	
					KL	
					HP	
					SSC	
					SMC	
					W	
					Z	
					PC	
	ACET843 2mm Low Line External Gasket	200	m		MF	
					SA	
					KL	
					HP	
					SSC	
					SMC	
					W	
					Z	
					PC	
	ACET844 2mm Low Line Gasket	200	m		MF	
					SA	
					KL	
					HP	
					SSC	
					SMC	
					W	
					Z	
					PC	
 <small>T-BARS ACVG66=2.5mm ACVG66=3.0mm ACVL150=4.0mm</small>	 <small>Screw (Grub)</small>	MF = Mill Finish SA = Silver Anodised KL = Basic Colour HP = Special Colour SSC = Smooth Satin Chrome SMC = Smokey Chrome PC = Polished Chrome	W = White Z = Black			

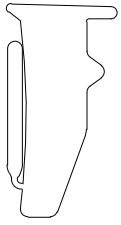
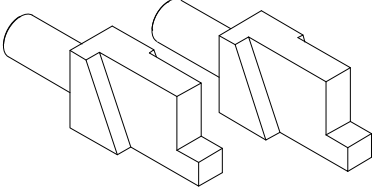

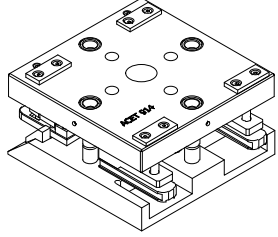
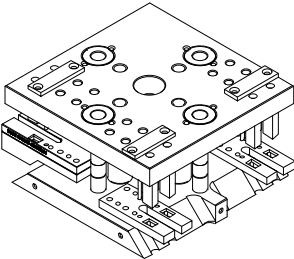


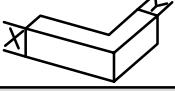
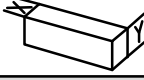
Image	Part Code	Pack	Unit	Application	Colour
	ACET848 5mm to 4mm Low Line Tear-Off Wedge Gasket	200	m		MF SA KL HP SSC SMC W Z PC
	ACET904 Crimping Punch	1	pair	ETC610 ETC6105 ETC612 ETC613 ETC614 ETC618 ETC619 ETC620 ETC622 ETC623 ETC624 ETC625 ETC647	MF SA KL HP SSC SMC W Z PC
	ACET907 Stepped Twist Drill for Corner Joints	1	each	ETC620 ETC623 ETC624 ETC625	MF SA KL HP SSC SMC W Z PC
	ACET914 Punch Tool	1	each	ETC610 ETC6105 ETC611 ETC612 ETC613 ETC614 ETC616 ETC618 ETC619 ETC631 ETC633 ETC635 ETC636 ETC638	MF SA KL HP SSC SMC W Z PC
	ACET939 Punch Tool	1	each	ETC6101 ETC624 ETC628 ETC629 ETC645	MF SA KL HP SSC SMC W Z PC
 <p>T-BARS ACVG65=2.5mm ACVG66=3.0mm ACVL150=4.0mm</p>  <p>Screw (Grub)</p>	MF = Mill Finish SA = Silver Anodised KL = Basic Colour HP = Special Colour SSC = Smooth Satin Chrome SMC = Smokey Chrome PC = Polished Chrome	W = White Z = Black	 		

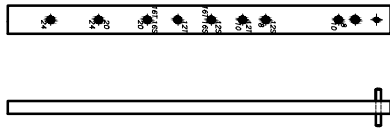
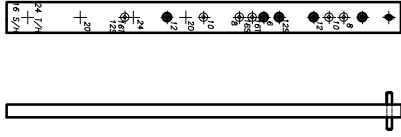
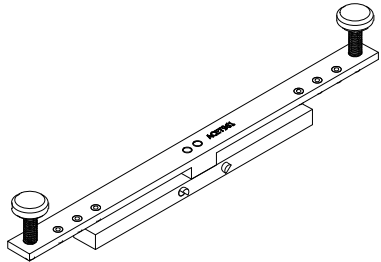
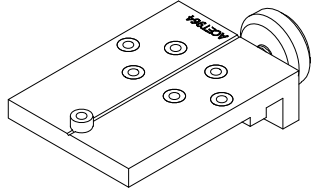
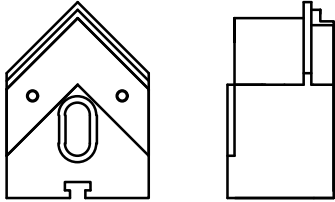


Image	Part Code	Pack	Unit	Application	Colour
	ACET943 Friction Hinge Drill Jig For Standard Top Hung & Side Hung (16mm Stack)	1	each	ETC620 ETC621 ETC623 ETC624 ETC625 ETC629	MF
					SA
	ACET944 Friction Hinge Drill Jig For Standard Top Hung & Side Hung (13mm Stack)	1	each	ETC622	KL
					HP
	ACET961 Drill Jig	1	each	ACET695 ETC624 ETC628 ETC629	SSC
					SMC
	ACET964 Drill Jig	1	each	ETC6305	W
					Z
	ACET979 Vee Block	1	each	ETC621	PC
	MF = Mill Finish SA = Silver Anodised KL = Basic Colour HP = Special Colour SSC = Smooth Satin Chrome SMC = Smokey Chrome PC = Polished Chrome	W = White Z = Black			

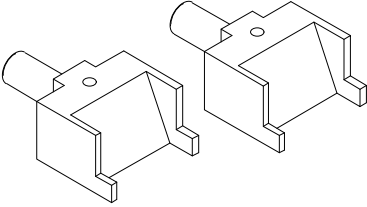
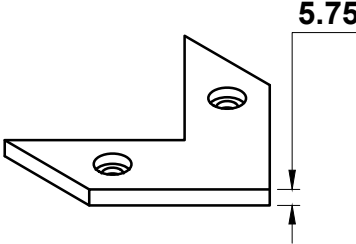
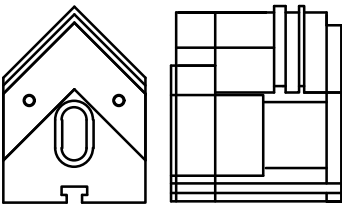
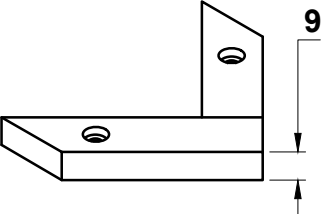
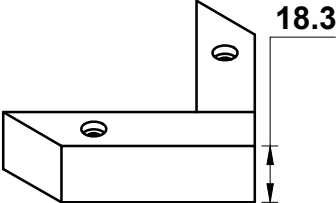

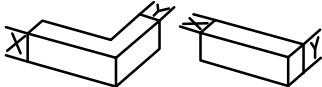
Image	Part Code	Pack	Unit	Application	Colour
	ACET981 Crimping Punch	1	pair	ETC621	MF SA KL HP SSC SMC W Z PC
	ACET983 5.75mm Packer for use with Vee Block ACET982	1	each	ETC615	MF SA KL HP SSC SMC W Z PC
	ACET984 Vee Block	1	each	ETC610 ETC6105 ETC612 ETC613 ETC614 ETC618 ETC619 ETC620 ETC625	MF SA KL HP SSC SMC W Z PC
	ACET985 9mm Packer for use with vee block ACET984	1	each	ETC610 ETC6105 ETC612 ETC613 ETC614 ETC618 ETC619 ETC620 ETC625	MF SA KL HP SSC SMC W Z PC
	ACET986 18.3mm Packer for use with vee block ACET984	1	each	ETC613	MF SA KL HP SSC SMC W Z PC
	MF = Mill Finish SA = Silver Anodised KL = Basic Colour HP = Special Colour SSC = Smooth Satin Chrome SMC = Smokey Chrome PC = Polished Chrome	W = White Z = Black			

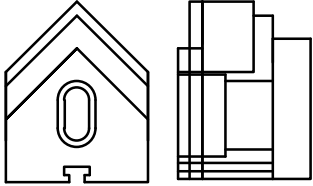
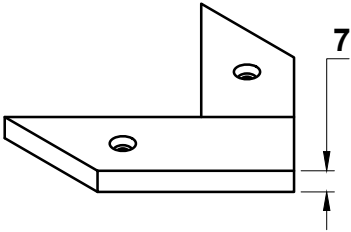
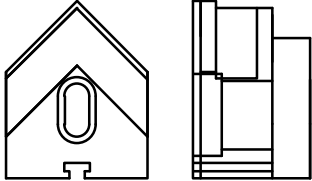
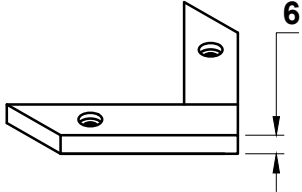
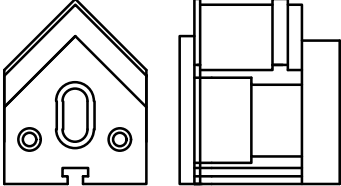

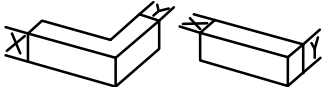
Image	Part Code	Pack	Unit	Application	Colour
	ACET987 Vee Block	1	each	ETC623 ETC624	MF SA KL HP SSC SMC W Z PC
	ACET988 7mm Packer for use with vee block ACET987	1	each	ETC615 ETC623 ETC624 ETC6101	MF SA KL HP SSC SMC W Z PC
	ACET989 Vee Block	1	each	ETC647	MF SA KL HP SSC SMC W Z PC
	ACET992 6mm Packer used with vee block ACET979	1	each	ETC621	MF SA KL HP SSC SMC W Z PC
	ACET993 Vee Block	1	each	ETC615	MF SA KL HP SSC SMC W Z PC
	MF = Mill Finish SA = Silver Anodised KL = Basic Colour HP = Special Colour SSC = Smooth Satin Chrome SMC = Smokey Chrome PC = Polished Chrome	W = White Z = Black			

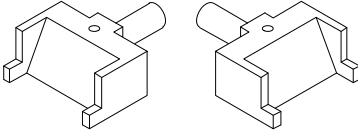
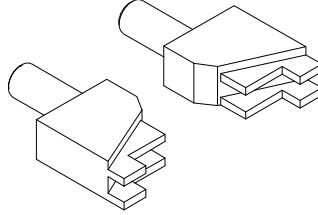
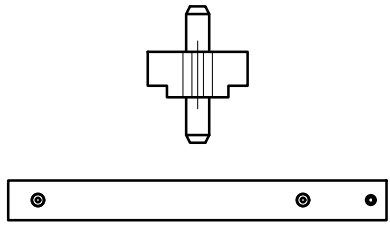
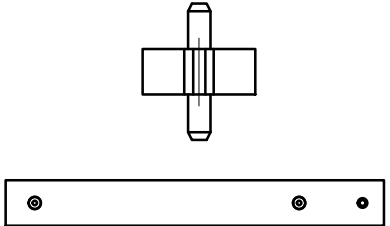
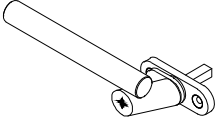


Image	Part Code	Pack	Unit	Application	Colour
	ACET997 Crimping Punch	1	pair	ETC615	MF
					SA
					KL
					HP
					SSC
					SMC
					W
					Z
					PC
					
SA					
KL					
HP					
SSC					
SMC					
W					
Z					
PC					
	ACETME93 Drill Jig for ACETME13	1	each	ACETME13	
					SA
					KL
					HP
					SSC
					SMC
					W
					Z
					PC
					
SA					
KL					
HP					
SSC					
SMC					
W					
Z					
PC					
 <p>LEFT HAND SHOWN</p>	ACSM010SS L/R Casement Window Handle with 9mm Spindle	1	each		
					SA
					KL
					HP
					SSC
					SMC
					W
					Z
					PC
					 <p>T-BARS ACVG65=2.5mm ACVG66=3.0mm ACVL150=4.0mm</p>  <p>Screw (Grub)</p>

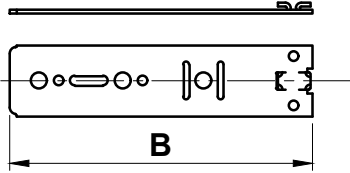
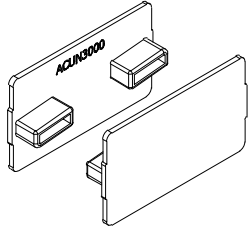

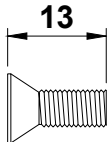
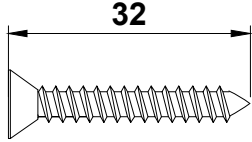

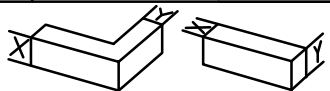
Image	Part Code	Pack	Unit	Application	Colour
	ACUN23X Screw Fixing Lug B x 38mm x 2mm ACUN230: B = 160mm ACUN232: B = 240mm ACUN233: B = 280mm	1	each	ETC052	MF
					SA
	ACUN3000 End Caps for UN3000	10	pairs	UN3000	KL
					HP
	ACUN3050 French Casement Locking Kit	1	kit	ACET649 ACET650 ACET651 ETC649	SSC
					SMC
	ACUN3501 M6 x 13 S/S Socket CSK Machine Screw	48	pack		W
					Z
	ACUN3512 No.8 x 32mm CSK SS Pozi Screw	100	pack		PC
 <p>T-BARS ACVG66=2.5mm ACVG66=3.0mm ACVL150=4.0mm</p> <p>Screw (Grub)</p>	MF = Mill Finish SA = Silver Anodised KL = Basic Colour HP = Special Colour SSC = Smooth Satin Chrome SMC = Smokey Chrome PC = Polished Chrome	W = White Z = Black			

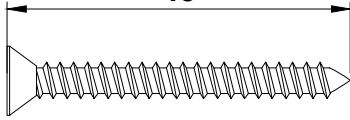
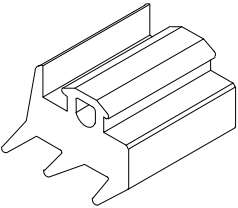
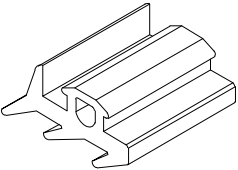
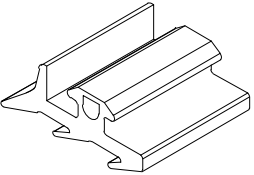
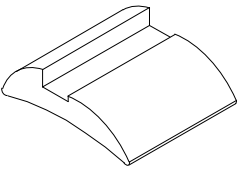


Image	Part Code	Pack	Unit	Application	Colour	
	ACUN3513 No.8 x 45mm CSK SS Pozi Screw	100	pack		MF	
					SA	
					KL	
					HP	
					SSC	
					SMC	
					W	
					Z	
					PC	
						ACVG131S 4mm External Gasket
SA						
KL						
HP						
SSC						
SMC						
W						
Z	✓					
PC						
	ACVG231 2mm External Gasket	100	m			
					SA	
					KL	
					HP	
					SSC	
					SMC	
					W	
					Z	✓
					PC	
						ACVG31S 3mm External Gasket
SA						
KL						
HP						
SSC						
SMC						
W						
Z	✓					
PC						
	ACVG32 3mm Wedge Gasket	100	m			
					SA	
					KL	
					HP	
					SSC	
					SMC	
					W	
					Z	✓
					PC	
					 T-BARS ACVG65=2.5mm ACVG66=3.0mm ACVL150=4.0mm	 Screw (Grub)

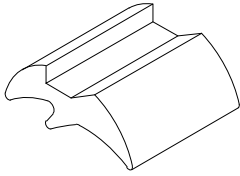
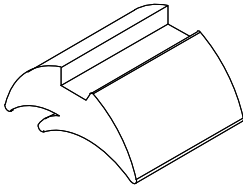
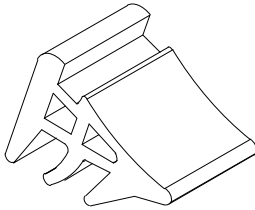
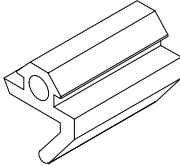
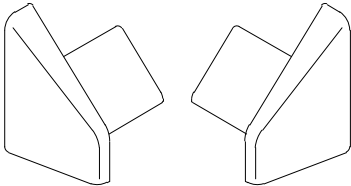


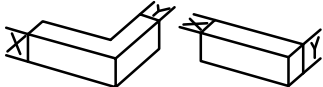




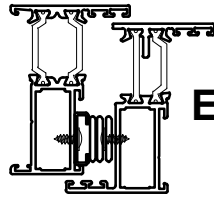
Image	Part Code	Pack	Unit	Application	Colour	
	ACVG33 4mm Wedge Gasket	100	m		MF	
					SA	
					KL	
					HP	
					SSC	
					SMC	
					W	
					Z	✓
					PC	
	ACVG34 5mm Wedge Gasket	100	m		MF	
					SA	
					KL	
					HP	
					SSC	
					SMC	
					W	
					Z	✓
					PC	
	ACVG49 6mm Wedge Gasket	100	m	ETC613	MF	
					SA	
					KL	
					HP	
					SSC	
					SMC	
					W	
					Z	✓
					PC	
	ACVL032 Flipper Gasket	100	m		MF	
					SA	
					KL	
					HP	
					SSC	
					SMC	
					W	
					Z	✓
					PC	
	ACVL059 End Caps	1	pair	VL72	MF	
					SA	
					KL	
					HP	
					SSC	
					SMC	
					W	✓
					Z	✓
					PC	
 T-BARS ACVG65=2.5mm ACVG66=3.0mm ACVL150=4.0mm	 Screw (Grub)	MF = Mill Finish SA = Silver Anodised KL = Basic Colour HP = Special Colour SSC = Smooth Satin Chrome SMC = Smokey Chrome PC = Polished Chrome	W = White Z = Black			

Image	Part Code	Pack	Unit	Application	Colour	
	ACVL635 End Cap (Black Only)	1	each	ETC636	MF	
					SA	
					KL	
					HP	
					SSC	
					SMC	
					W	
					Z	
					PC	
						ACVS010 PVC Insert
SA						
KL						
HP						
SSC						
SMC						
W						
Z						
PC						
	ACW20034 4mm Low Line Wedge Gasket	200	m			
					SA	
					KL	
					HP	
					SSC	
					SMC	
					W	
					Z	✓
					PC	
						ACW20038 4mm to 3mm Tear-off Low Line Wedge Gasket
SA						
KL						
HP						
SSC						
SMC						
W						
Z	✓					
PC						
	ACW20432 Keep	2	pack	ETC610 ETC611 ETC612 ETC613 ETC614 ETC615 ETC618 ETC616 ETC619		
					SA	
					KL	
					HP	
					SSC	
					SMC	
					W	
					Z	✓
					PC	
					<p>T-BARS ACVG65=2.5mm ACVG66=3.0mm ACVL150=4.0mm</p> <p>Screw (Grub)</p>	MF = Mill Finish SA = Silver Anodised KL = Basic Colour HP = Special Colour SSC = Smooth Satin Chrome SMC = Smokey Chrome PC = Polished Chrome

Image	Part Code	Pack	Unit	Application	Colour
	WCA106 Stainless Steel Chevron	100	pack	ETC623	MF
					SA
					KL
					HP
					SSC
					SMC
					W
					Z
					PC
	WUT024HSZA Manual Crimper Note: Vee blocks & punches are sold separately	1	each		MF
					SA
					KL
					HP
					SSC
					SMC
					W
					Z
					PC
					MF
					SA
					KL
					HP
					SSC
					SMC
					W
					Z
					PC
					MF
					SA
					KL
					HP
					SSC
					SMC
					W
					Z
					PC
<p>T-BARS ACVG65=2.5mm ACVG66=3.0mm ACVL150=4.0mm</p> <p>Screw (Grub)</p>	MF = Mill Finish SA = Silver Anodised KL = Basic Colour HP = Special Colour SSC = Smooth Satin Chrome SMC = Smokey Chrome PC = Polished Chrome				MF
					SA
					KL
					HP
					SSC
					SMC
					W
					Z
					PC
		W = White Z = Black			

Image	Part Code	Pack	Unit	Application	Colour
					MF SA KL HP SSC SMC W Z PC
					MF SA KL HP SSC SMC W Z PC
					MF SA KL HP SSC SMC W Z PC
					MF SA KL HP SSC SMC W Z PC
					MF SA KL HP SSC SMC W Z PC
 <p>T-BARS ACVG65=2.5mm ACVG66=3.0mm ACVL150=4.0mm</p>  <p>Screw (Grub)</p>	<p>MF = Mill Finish SA = Silver Anodised KL = Basic Colour HP = Special Colour SSC = Smooth Satin Chrome SMC = Smokey Chrome PC = Polished Chrome</p>	<p>W = White Z = Black</p>	 		

Friction Hinge Stays 13mm Stack (Standard)

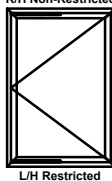
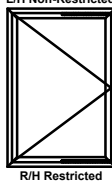
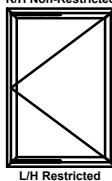
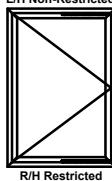


ETC622

Top Hung Windows

Top Hung	Type of Hinge / Stay	Max. Vent	Height ('A')		Opening Angle (+/- 2.5°)
		Weight (kgs)	Minimum	Maximum	
ACINDS10	Standard	16	275	400	80°
ACINDS16		21	400	780	80°
ACINDS20		26	700	1100	50°
ACINDS24		40	850	1300	37.5°
ACINDP24	Heavy Duty	50	850	1500	32°
ACINDA10	Austenitic	16	275	400	80°
ACINDA16		21	400	780	80°
ACINDA20		26	700	1100	50°
ACINDA24		40	850	1300	37.5°
ACINDR12	Restricted	20	350	550	14°/65°
ACINDR16		21	500	780	10°/59°
ACINDR20		26	700	1100	8°/50°
ACINDR24		40	850	1300	7°/37.5°

Side Hung Windows

Side Hung	Type of Hinge / Stay	Max. Vent	Width ('A')		Opening Angle (+/- 2.5°)
		Weight (kgs)	Minimum	Maximum	
ACINDSSH12	Standard	22	300	600	60°
ACINDSSH16		24	400	600	60°
ACINDASH12	Austenitic	22	300	600	60°
ACINDASH16		24	400	600	60°
ACETSH1312L ACETSH1312R	Restricted Left Hand R/H Non-Restricted  Right Hand L/H Non-Restricted 	22	300	600	13°/58°
ACETSH1316L ACETSH1316R	 VIEWED FROM OUTSIDE  L/H Restricted R/H Restricted	24	400	600	11°/58°
ACETME13	Egress *use with ACET352 pull in blocks	40	365	865	90°

Note1: Vent Height / Width is measured in mm from rebate to rebate (not overall size or outer frame)

Note2: Top hung height and side hung width sizes to be reduced by 2mm where size is 450mm or smaller

Note3: Typical Dimensions based on Max. Size and Glass 30kg/metre

Note4: For additional security use ACET513 hinge protectors

Note5: Kitemark specification covers Top Hung Max. height up to 1400mm. ACINDP24 Max. height is 1500mm

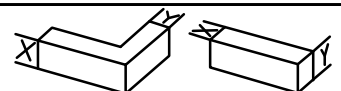
Note6: For sashes over 600mm, ACETME99 is recommended for ACETME13 to disable easy clean function



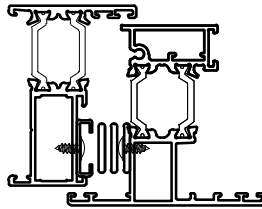
T-BARS
ACVG66=2.5mm
ACVG66=3.0mm
ACVL150=4.0mm



Screw (Grub)



Friction Hinge Stays 16mm Stack (Standard)



ETC620 ETC625
ETC621 ETC627
ETC623 ETC628
ETC624 ETC629

Top Hung Windows

Top Hung	Type of Hinge / Stay	Max. Vent	Height		Opening Angle (+/- 2.5°)
		Weight (kgs)	Minimum	Maximum	
ACETDHS08	Standard	12	200	350	65°
ACETDHS10		16	275	400	80°
ACETDHS12		20	350	550	80°
ACETDHS16		21	500	780	80°
ACETDHS20		26	700	1100	50°
ACETDHS24		40	850	1300	37.5°
ACETDTH24	Heavy Duty	50	850	1500	32°
ACETDHS12R	Restricted	20	350	550	14° / 65°
ACETDHS16R		21	500	780	10° / 59°
ACETDHS20R		26	700	1100	8° / 50°
ACETDHS24R		40	850	1300	7° / 37.5°

Side Hung Windows

Side Hung	Type of Hinge / Stay	Max. Vent	Width ('A')		Opening Angle (+/- 2.5°)
		Weight (kgs)	Minimum	Maximum	
ACETDSSH12	Standard	22	300	600	60°
ACETDSSH16		24	400	600	60°
ACETSH1612L ACETSH1612R	Restricted Left Hand R/H Non-Restricted Right Hand L/H Non-Restricted	22	300	600	13°/58°
ACETSH1616L ACETSH1616R	VIEWED FROM OUTSIDE L/H Restricted R/H Restricted	24	400	600	11°/58°
ACETME16	Egress *use with ACET652 pull in blocks	40	365	865	90°

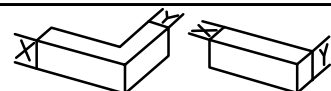
- Note1: Vent Height / Width is measured in mm from rebate to rebate (not overall size or outer frame)
 Note2: Top hung height and side hung width sizes to be reduced by 2mm where size is 450mm or smaller
 Note3: Typical Dimensions based on Max. Size and Glass 30kg/metre
 Note4: For additional security use ACET516 hinge protectors
 Note5: Kitemark specification covers Top Hung Max. height up to 1400mm.
 Note6: For sashes over 600mm, ACETME99 is recommended for ACETME16 to disable easy clean function

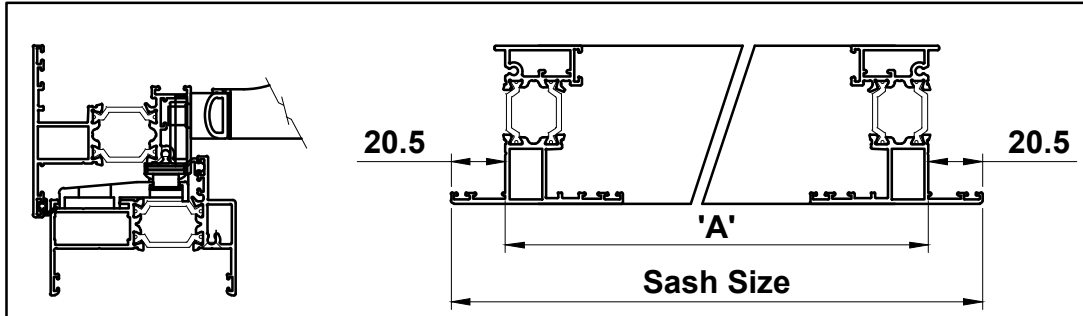


T-BARS
ACVG65=2.5mm
ACVG66=3.0mm
ACVL150=4.0mm



Screw (Grub)





Part Code	Rod Length (mm)	Number of Keeps	Sash Rebate Size ('A')	
			Minimum	Maximum
ACET601L	335	2	340	505
ACET601R				
ACET602L	500	2	506	755
ACET602R				
ACET603L	750	2	756	1005
ACET603R				
ACET604L	1000	4	1006	1255
ACET604R				
ACET605L	1250	4	1256	1400
ACET605R				

Note: To Suit Handle ACET165

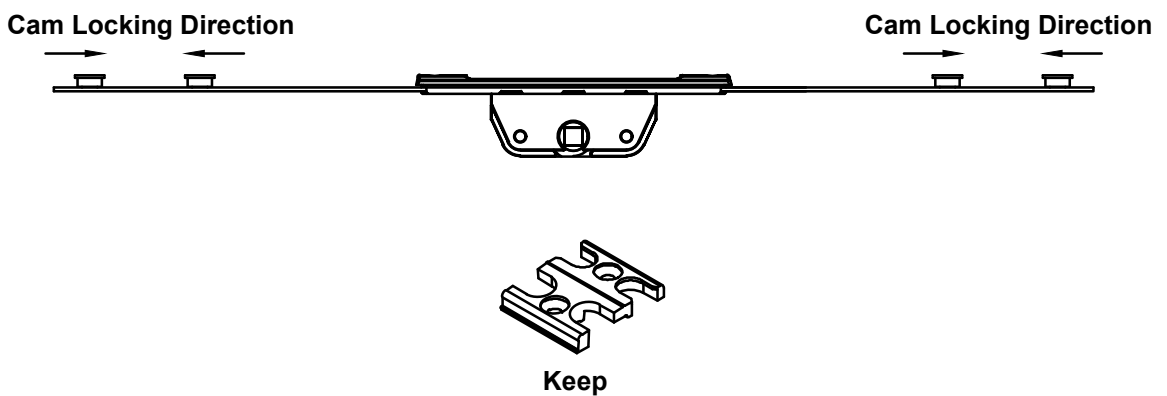


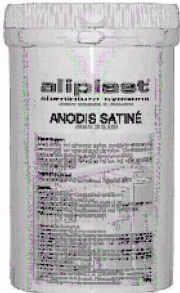


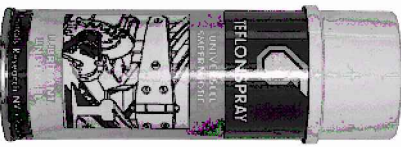



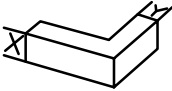
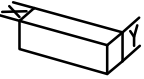












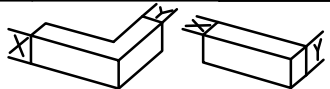
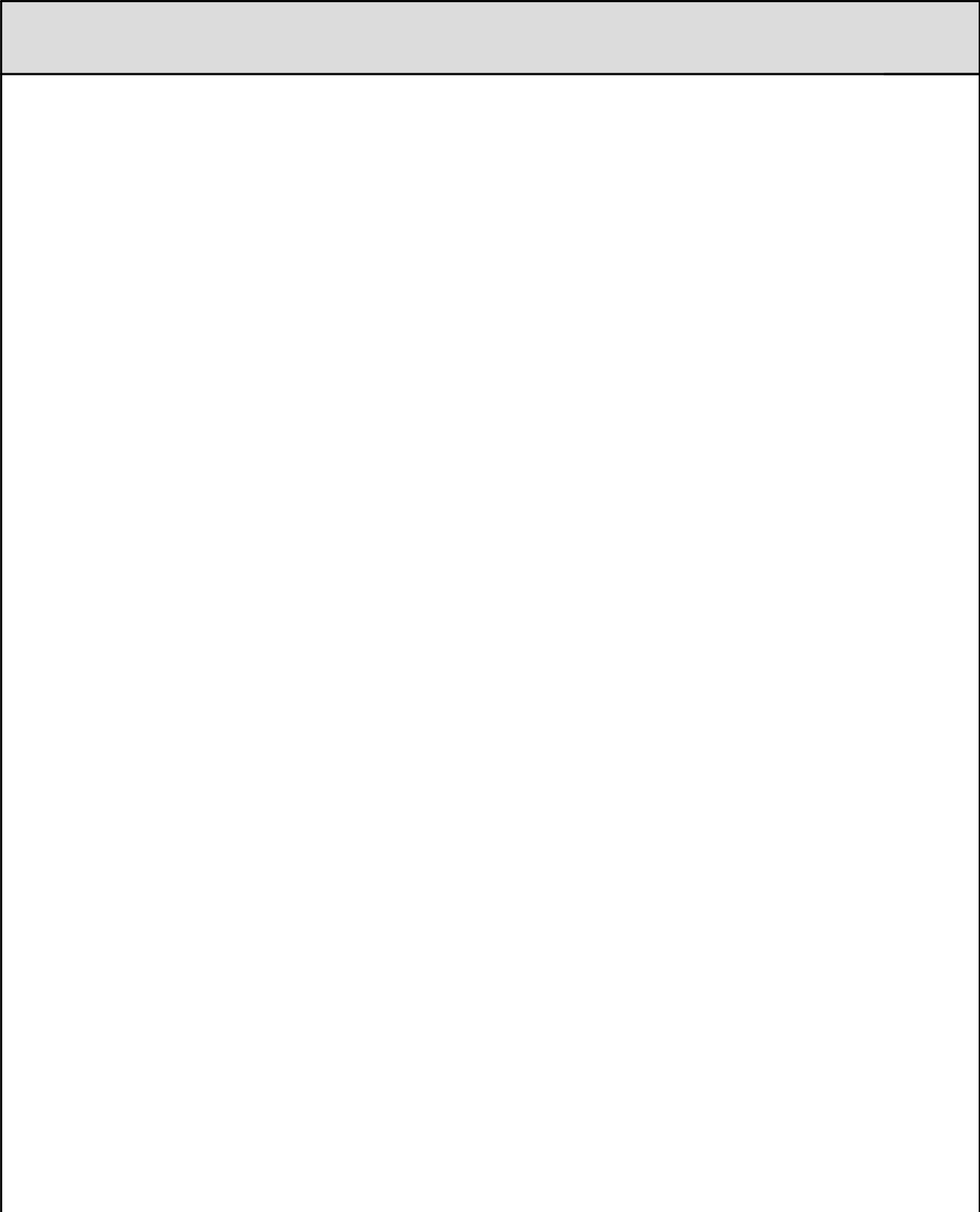
Image	Part Code	Pack	Unit	Application	Colour
	ACMX09700 Alu-Polish Cleaning emulsion for aluminium oxide.	1	each		MF <input checked="" type="checkbox"/> SA <input type="checkbox"/> KL <input type="checkbox"/> HP <input type="checkbox"/> SSC <input type="checkbox"/> SMC <input type="checkbox"/> W <input type="checkbox"/> Z <input type="checkbox"/> PC <input type="checkbox"/>
	ACMX09761 Maxi Gloss Protection for painted and anodised surfaces.	1	each		MF <input type="checkbox"/> SA <input type="checkbox"/> KL <input type="checkbox"/> HP <input type="checkbox"/> SSC <input type="checkbox"/> SMC <input type="checkbox"/> W <input type="checkbox"/> Z <input type="checkbox"/> PC <input type="checkbox"/>
	ACMX09762 Alu. Bright Cleaner for rough, anodised or enamelled aluminium frames.	1	each		MF <input type="checkbox"/> SA <input type="checkbox"/> KL <input type="checkbox"/> HP <input type="checkbox"/> SSC <input type="checkbox"/> SMC <input type="checkbox"/> W <input type="checkbox"/> Z <input type="checkbox"/> PC <input type="checkbox"/>
	ACMX09763 Teflon Spray Lubricant	1	each		MF <input type="checkbox"/> SA <input type="checkbox"/> KL <input type="checkbox"/> HP <input type="checkbox"/> SSC <input type="checkbox"/> SMC <input type="checkbox"/> W <input type="checkbox"/> Z <input type="checkbox"/> PC <input type="checkbox"/>
	ACMX09764 Maxi Cleaner For cleaning oily surfaces.	1	each		MF <input type="checkbox"/> SA <input type="checkbox"/> KL <input type="checkbox"/> HP <input type="checkbox"/> SSC <input type="checkbox"/> SMC <input type="checkbox"/> W <input type="checkbox"/> Z <input type="checkbox"/> PC <input type="checkbox"/>
 <p>T-BARS ACVG65=2.5mm ACVG66=3.0mm ACVL150=4.0mm</p>  <p>Screw (Grub)</p>	<p>MF = Mill Finish SA = Silver Anodised KL = Basic Colour HP = Special Colour SSC = Smooth Satin Chrome SMC = Smokey Chrome PC = Polished Chrome</p>	<p>W = White Z = Black</p>	 		

Image	Part Code	Pack	Unit	Application	Colour
	ACMX09765 Glue Cleaner (1 Litre) De-grease and silicone remover.	1	each		MF SA KL HP SSC SMC W Z PC
	ACMX09770 Roll & Wrap 100mm	1	each		MF SA KL HP SSC SMC W Z PC
	ACMX09775 Grip Handwrap	1	each		MF SA KL HP SSC SMC W Z PC
	ACMX09801 Protective Tape 50mm	1	each		MF SA KL HP SSC SMC W Z PC
	ACMX09802 Protective Tape 70mm	1	each		MF SA KL HP SSC SMC W Z PC
 <p>T-BARS ACVG65=2.5mm ACVG66=3.0mm ACVL150=4.0mm</p>  <p>Screw (Grub)</p>	MF = Mill Finish SA = Silver Anodised KL = Basic Colour HP = Special Colour SSC = Smooth Satin Chrome SMC = Smokey Chrome PC = Polished Chrome	W = White Z = Black		 	

Image	Part Code	Pack	Unit	Application	Colour
	ACMX09803 Protective Tape 100mm	1	each		MF SA KL HP SSC SMC W Z PC
	ACSIL05 Rubber Sealant	1	each		MF SA KL HP SSC SMC W Z PC
	ACSIL04 Sealing Glue Order with suffix of KL colour (eg.ACSIL04KL005) or BL=Black/WP=White/ CL=Clear	1	each		MF SA KL ✓ HP SSC SMC W ✓ Z ✓ PC
	ACSIL08 Silicon Gun	1	each		MF SA KL HP SSC SMC W Z PC
	ACSIL013 Glue for Mitre	1	each		MF SA KL HP SSC SMC W Z PC
 <p>T-BARS ACVG65=2.5mm ACVG66=3.0mm ACVL150=4.0mm</p>  <p>Screw (Grub)</p>	<p>MF = Mill Finish SA = Silver Anodised KL = Basic Colour HP = Special Colour SSC = Smooth Satin Chrome SMC = Smokey Chrome PC = Polished Chrome</p> <p>W = White Z = Black</p>	 			

STANDARD ACCESSORIES

Image	Part Code	Pack	Unit	Application	Colour	
	ACSIL014 Anti-Corrosion Coating	1	each		MF	✓
					SA	
					KL	
					HP	
					SSC	
					SMC	
					W	
					Z	
					PC	
	ACUN3900 Gasket Roller	1	Each	Wedge Gaskets	MF	
					SA	
					KL	
					HP	
					SSC	
					SMC	
					W	
					Z	
					PC	
					MF	
					SA	
					KL	
					HP	
					SSC	
					SMC	
					W	
					Z	
					PC	
					MF	
					SA	
					KL	
					HP	
					SSC	
					SMC	
					W	
					Z	
					PC	
 <p>T-BARS ACVG65=2.5mm ACVG66=3.0mm ACVL150=4.0mm</p> <p>Screw (Grub)</p>	MF = Mill Finish SA = Silver Anodised KL = Basic Colour HP = Special Colour SSC = Smooth Satin Chrome SMC = Smokey Chrome PC = Polished Chrome					W = White
						Z = Black
						



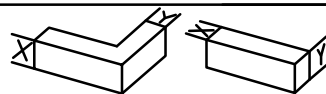
T-BARS
ACVG65=2.5mm
ACVG66=3.0mm
ACVL150=4.0mm



Screw (Grub)

MF = Mill Finish
SA = Silver Anodised
KL = Basic Colour
HP = Special Colour
SSC = Smooth Satin Chrome
SMC = Smokey Chrome
PC = Polished Chrome

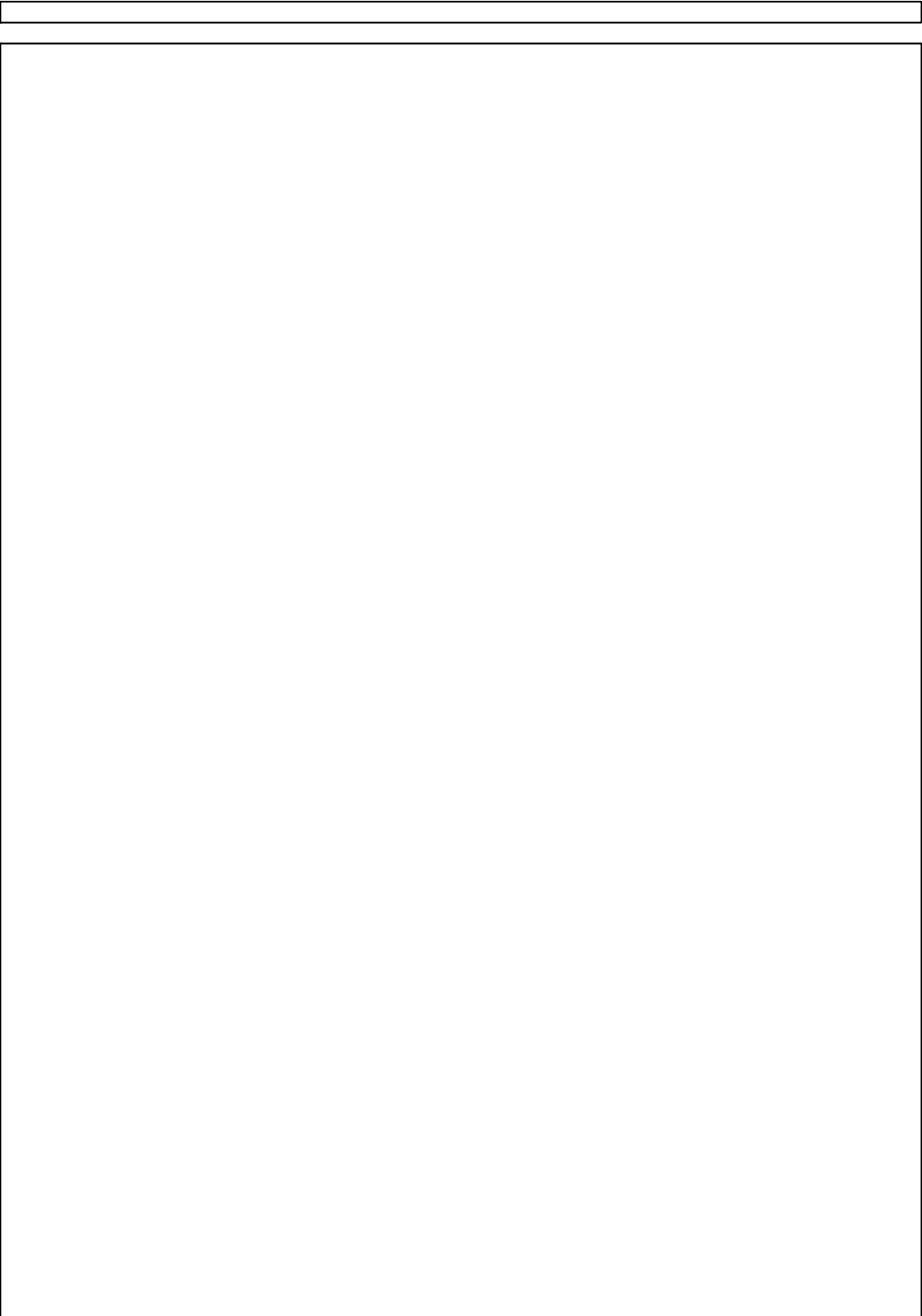
W = White
Z = Black



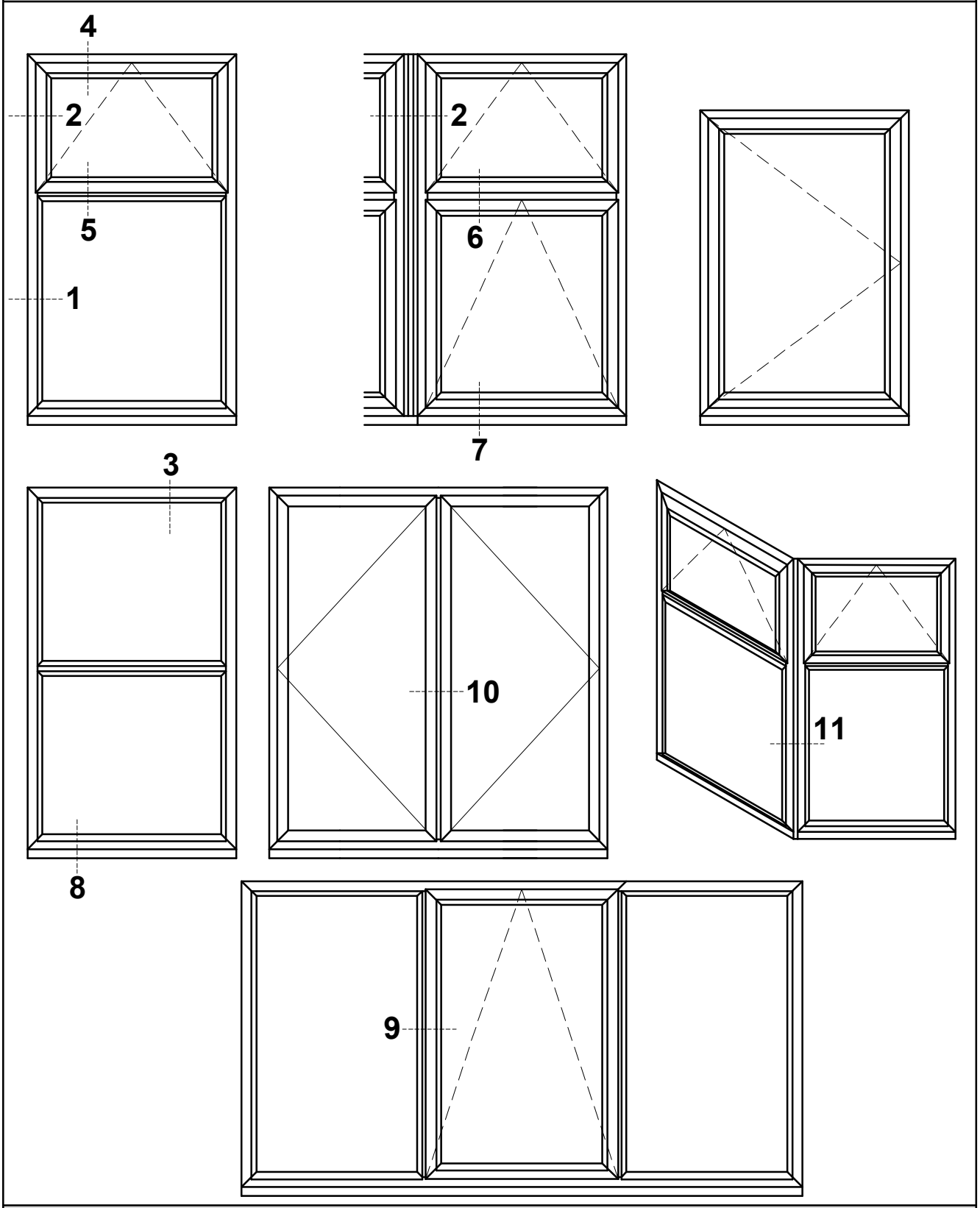
Section C

Sections

Scale Elevations

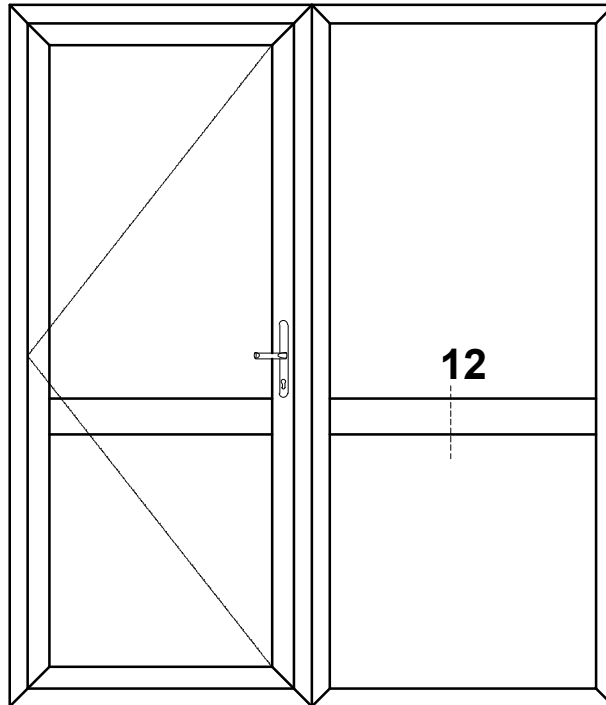


Scale Elevations



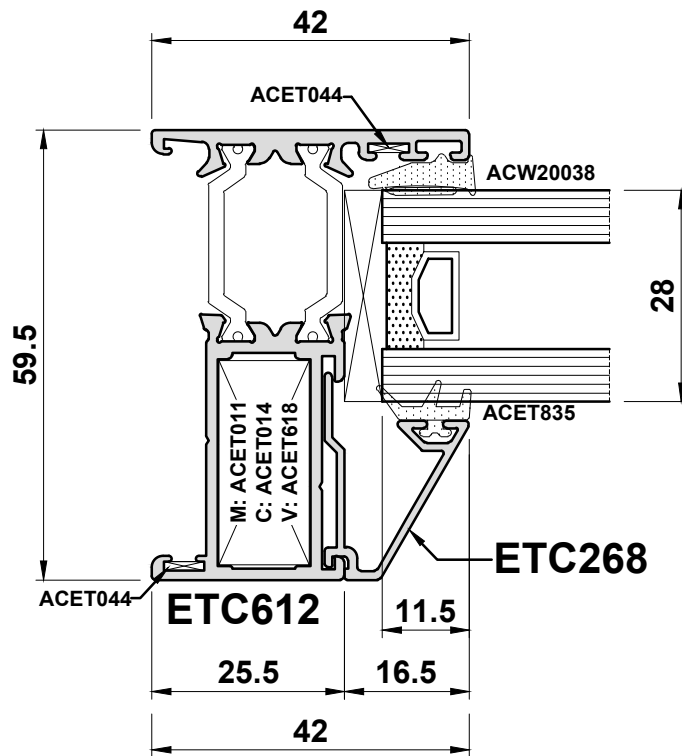
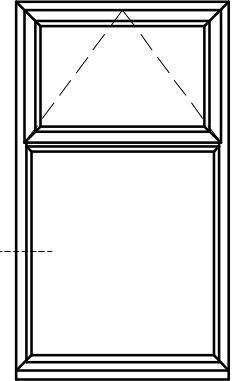
Do Not Scale From This Drawing

Scale Elevations



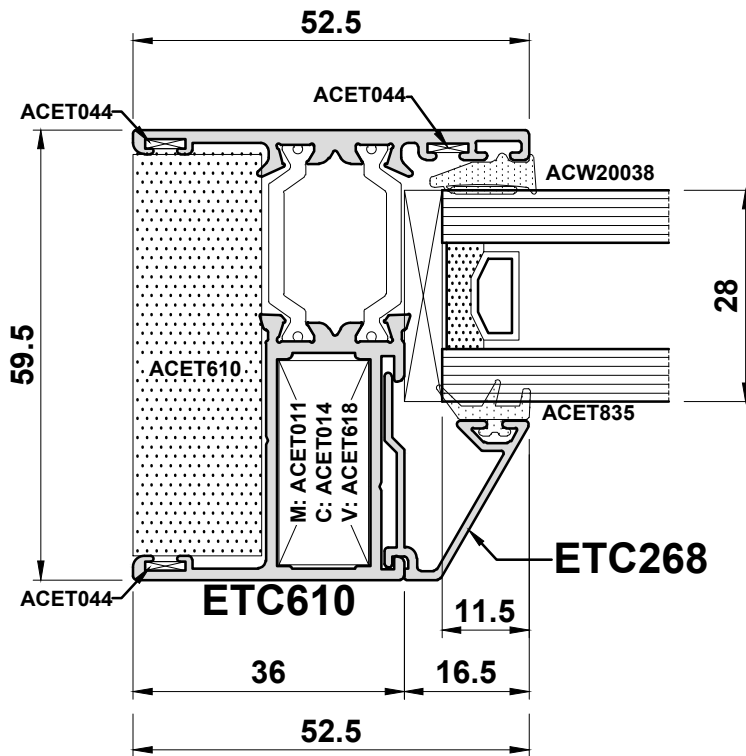
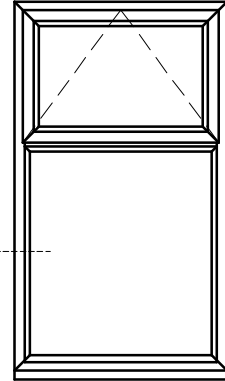
Do Not Scale From This Drawing

Detail 1A



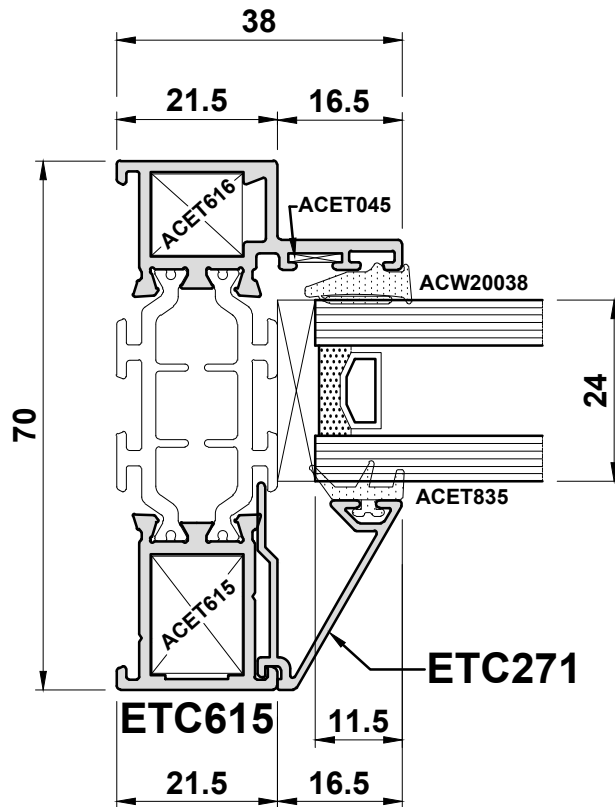
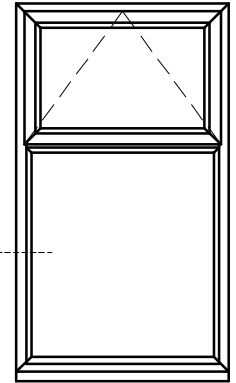
Do Not Scale From This Drawing

Detail 1B



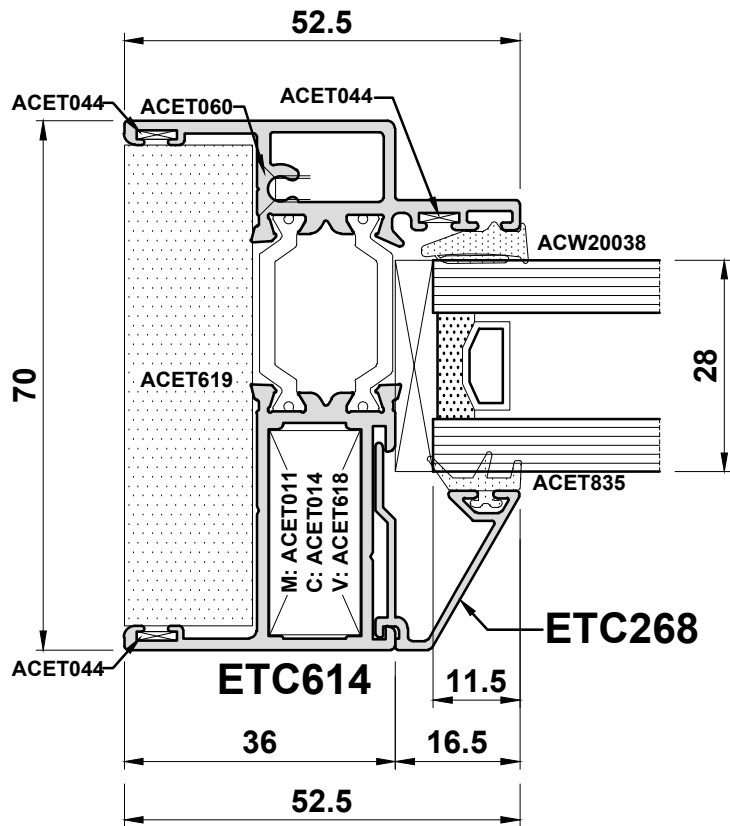
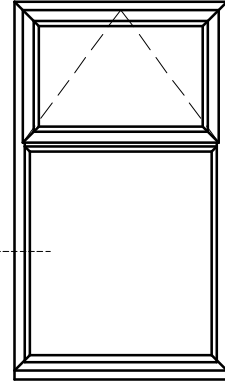
Do Not Scale From This Drawing

Detail 1C



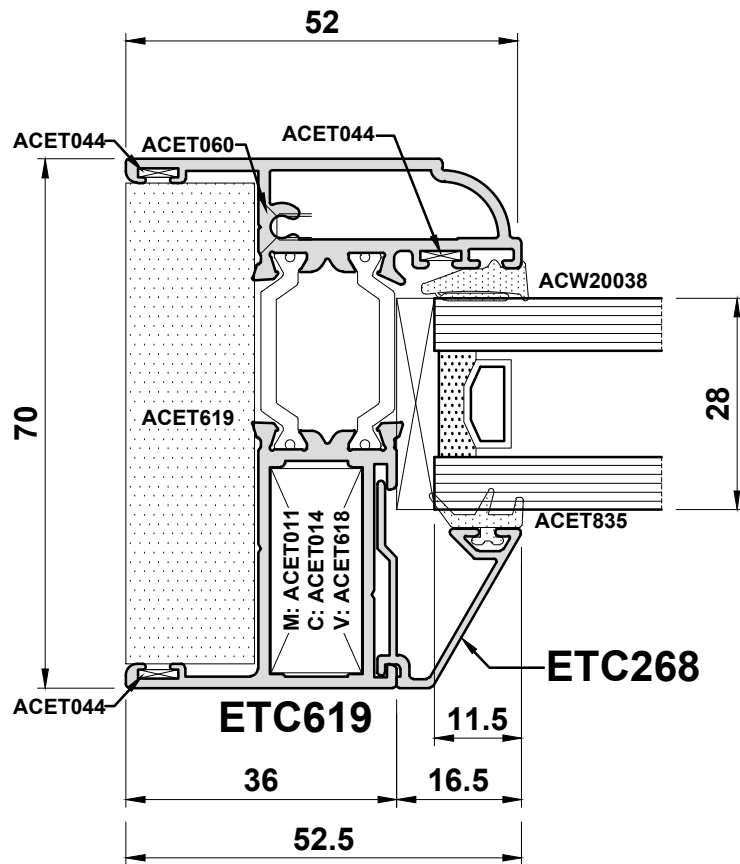
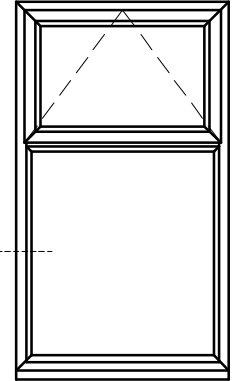
Do Not Scale From This Drawing

Detail 1D



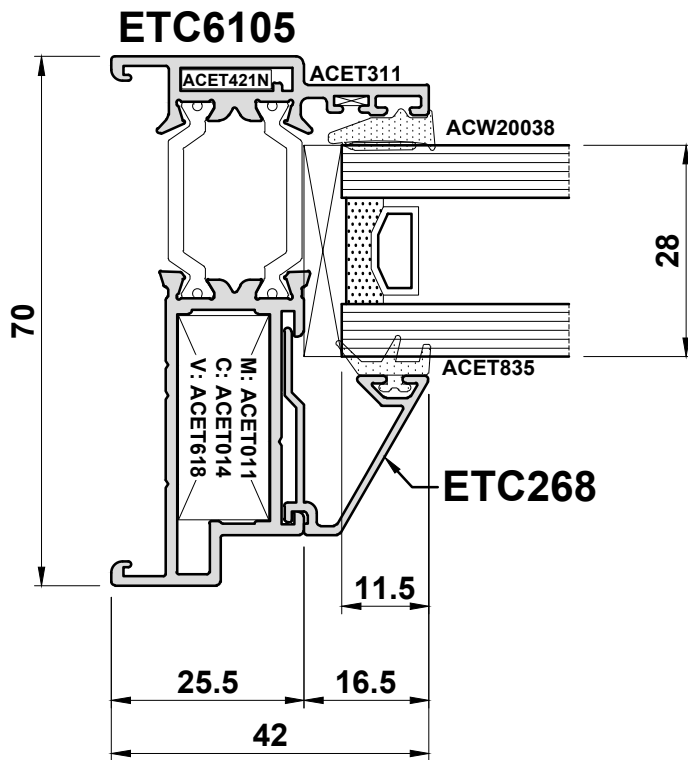
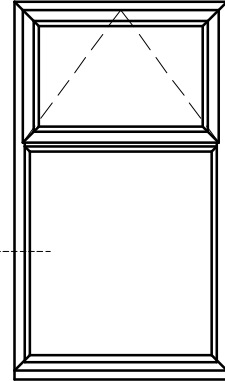
Do Not Scale From This Drawing

Detail 1E



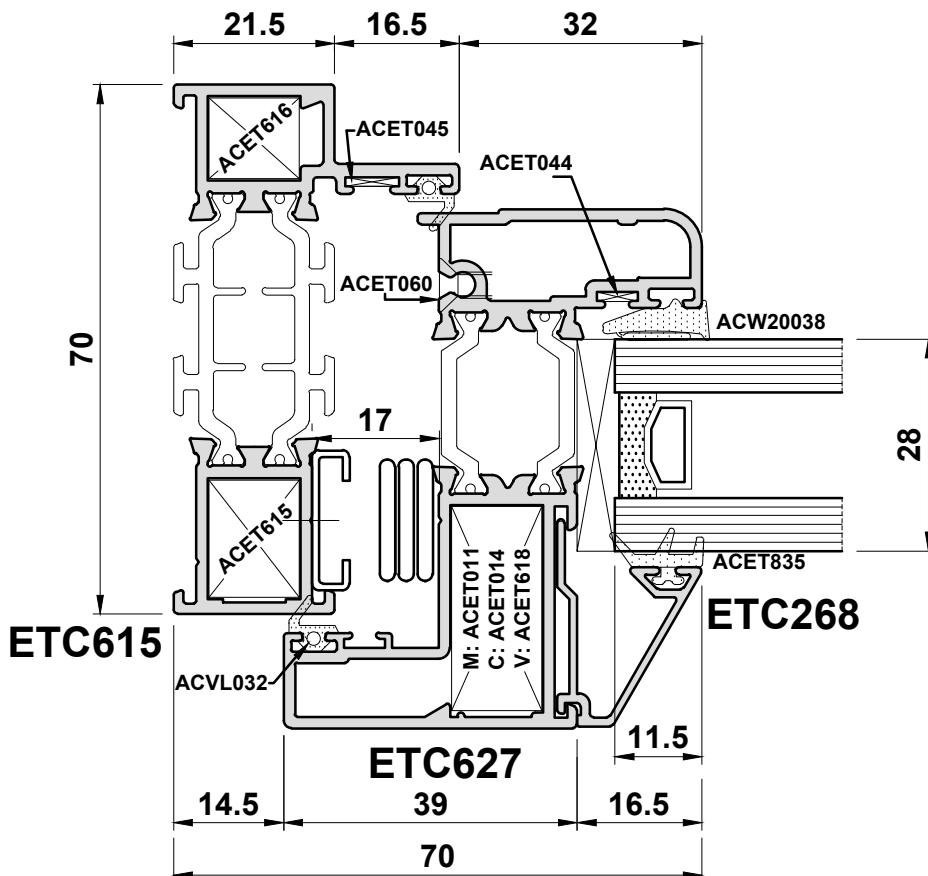
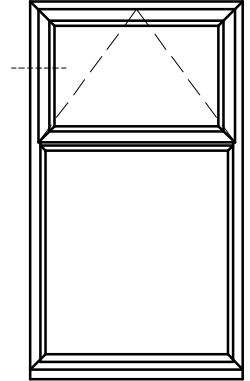
Do Not Scale From This Drawing

Detail 1F



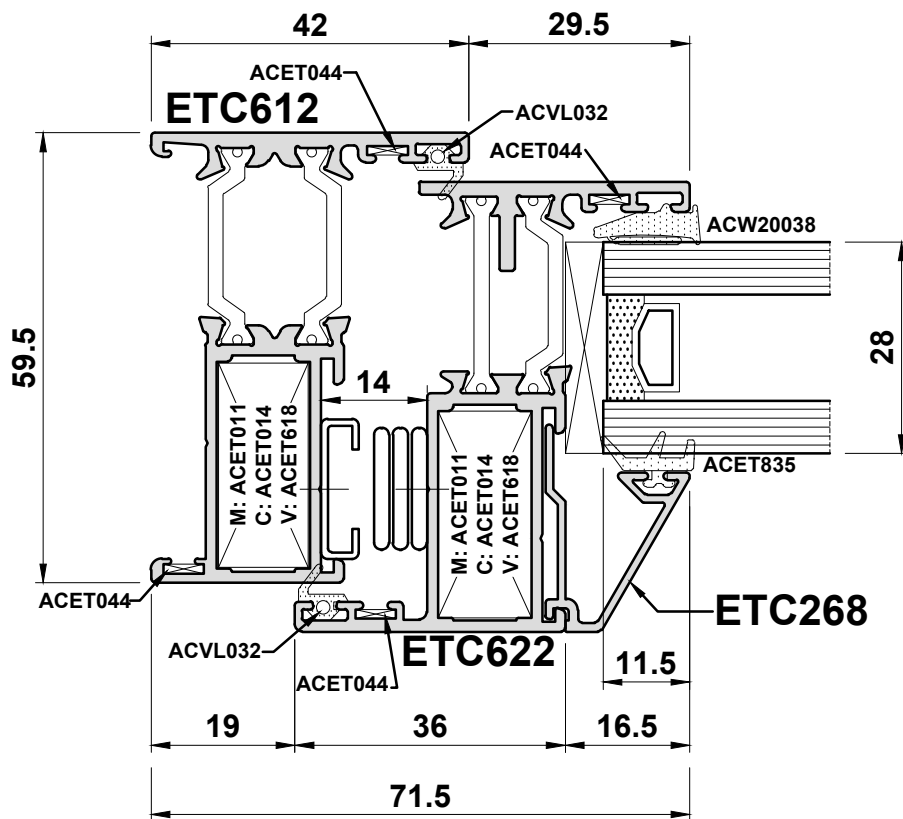
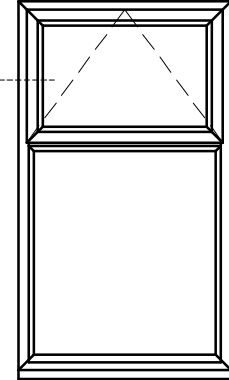
Do Not Scale From This Drawing

Detail 2A



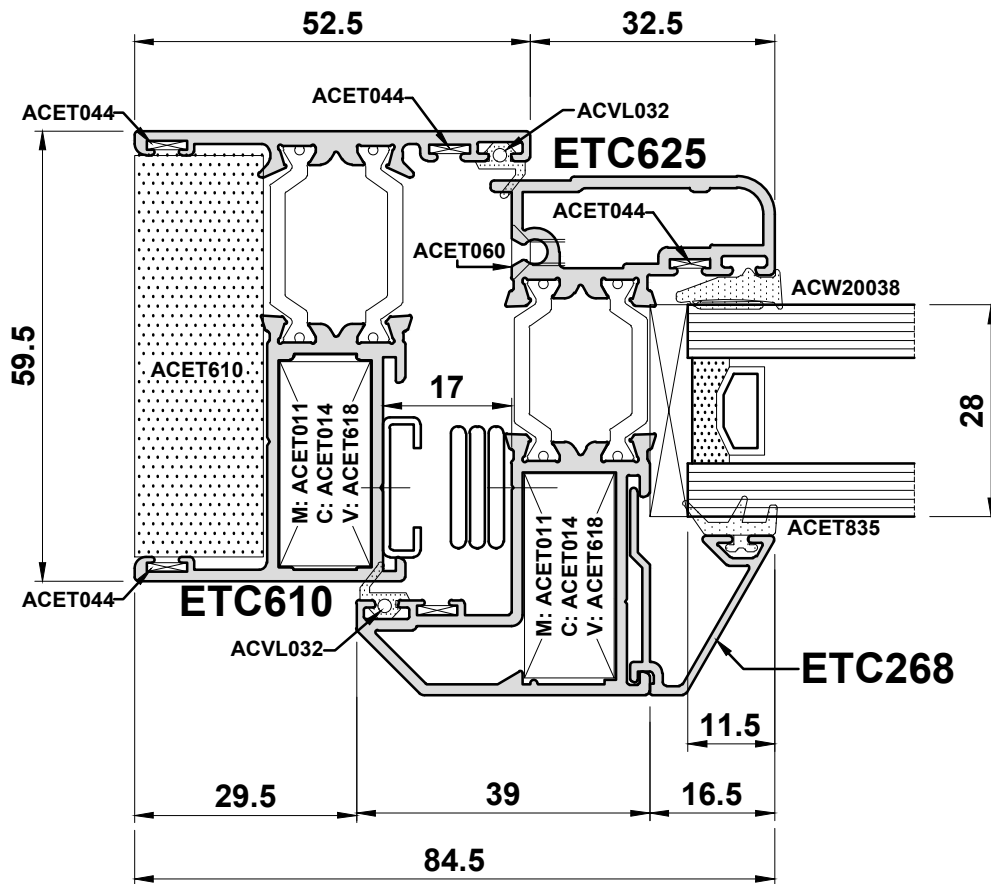
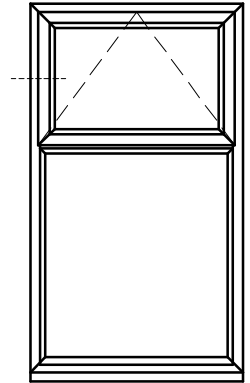
Do Not Scale From This Drawing

Detail 2B



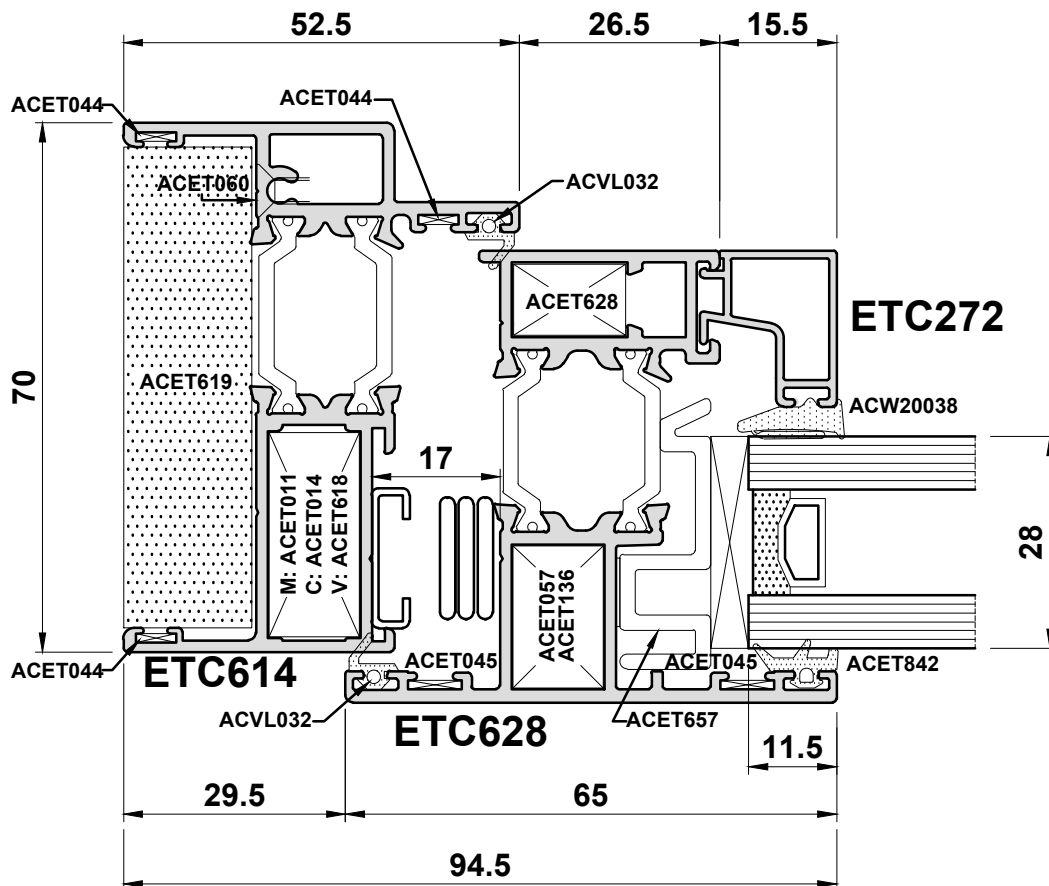
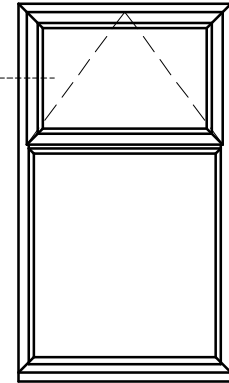
Do Not Scale From This Drawing

Detail 2C



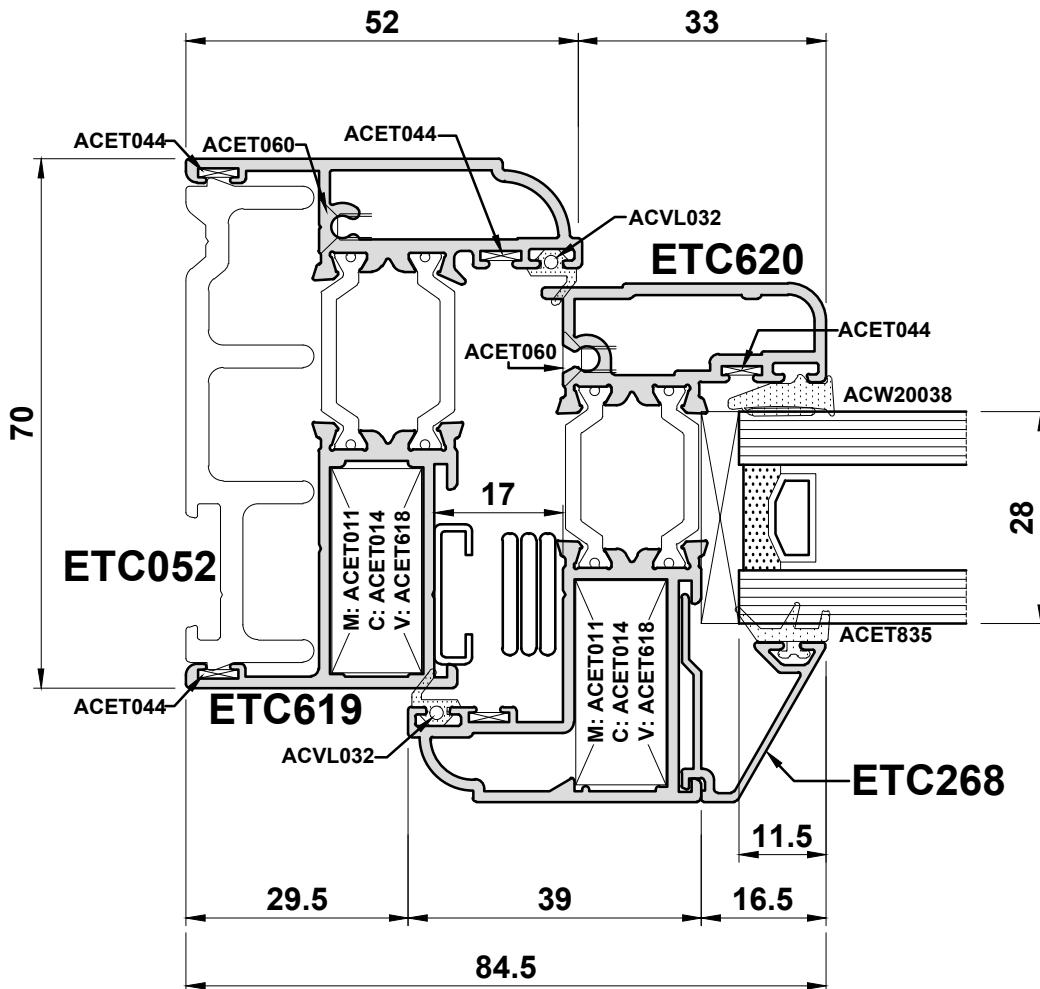
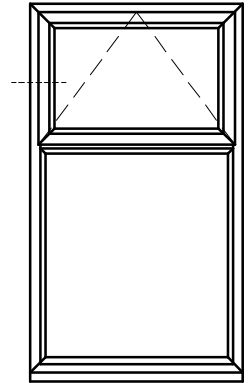
Do Not Scale From This Drawing

Detail 2D



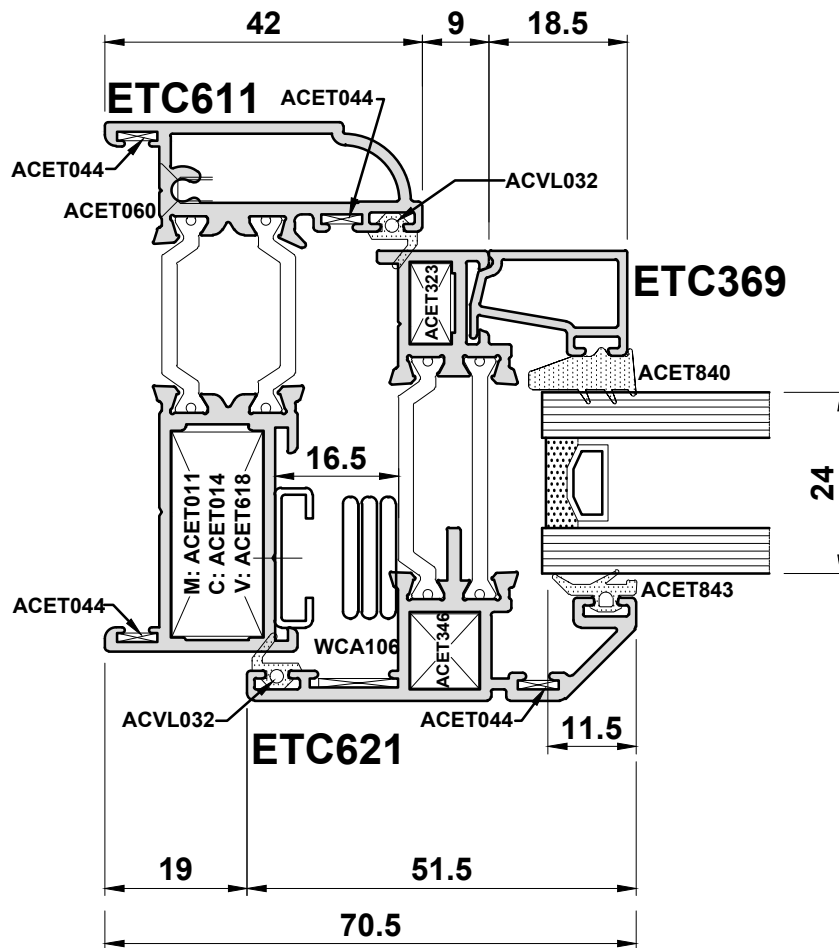
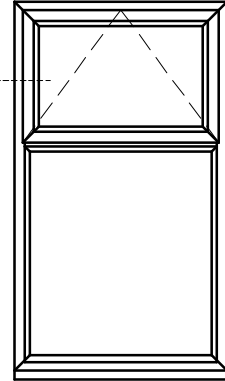
Do Not Scale From This Drawing

Detail 2E



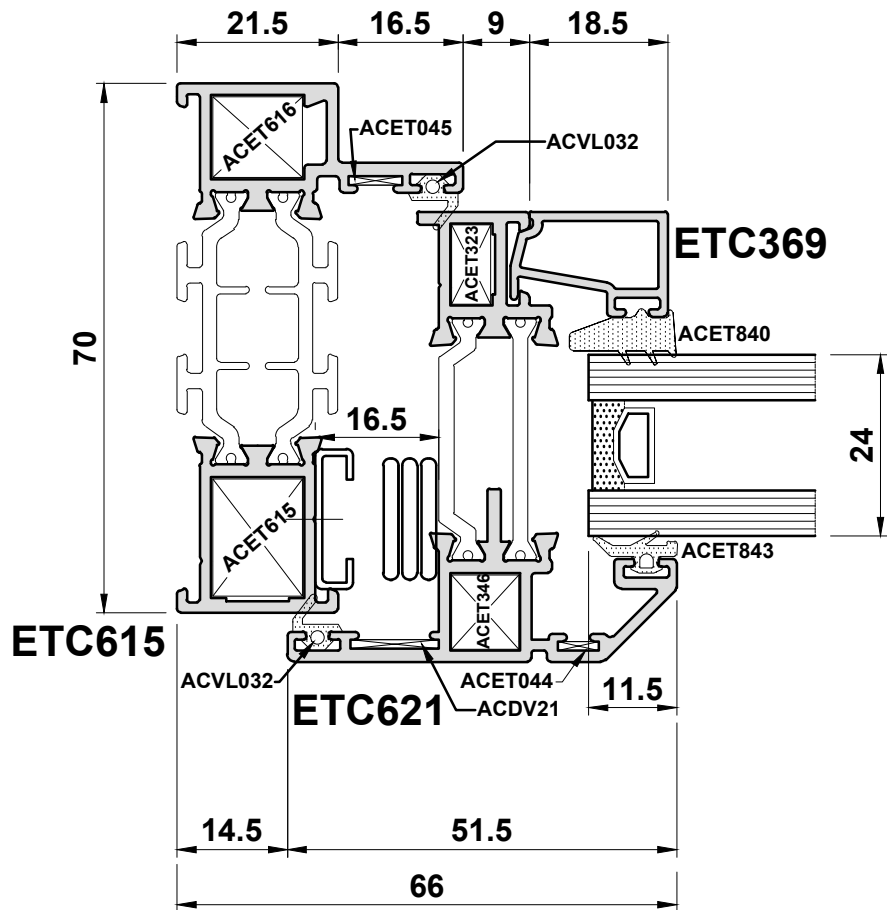
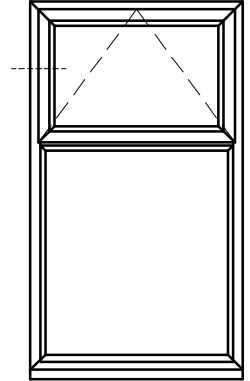
Do Not Scale From This Drawing

Detail 2F



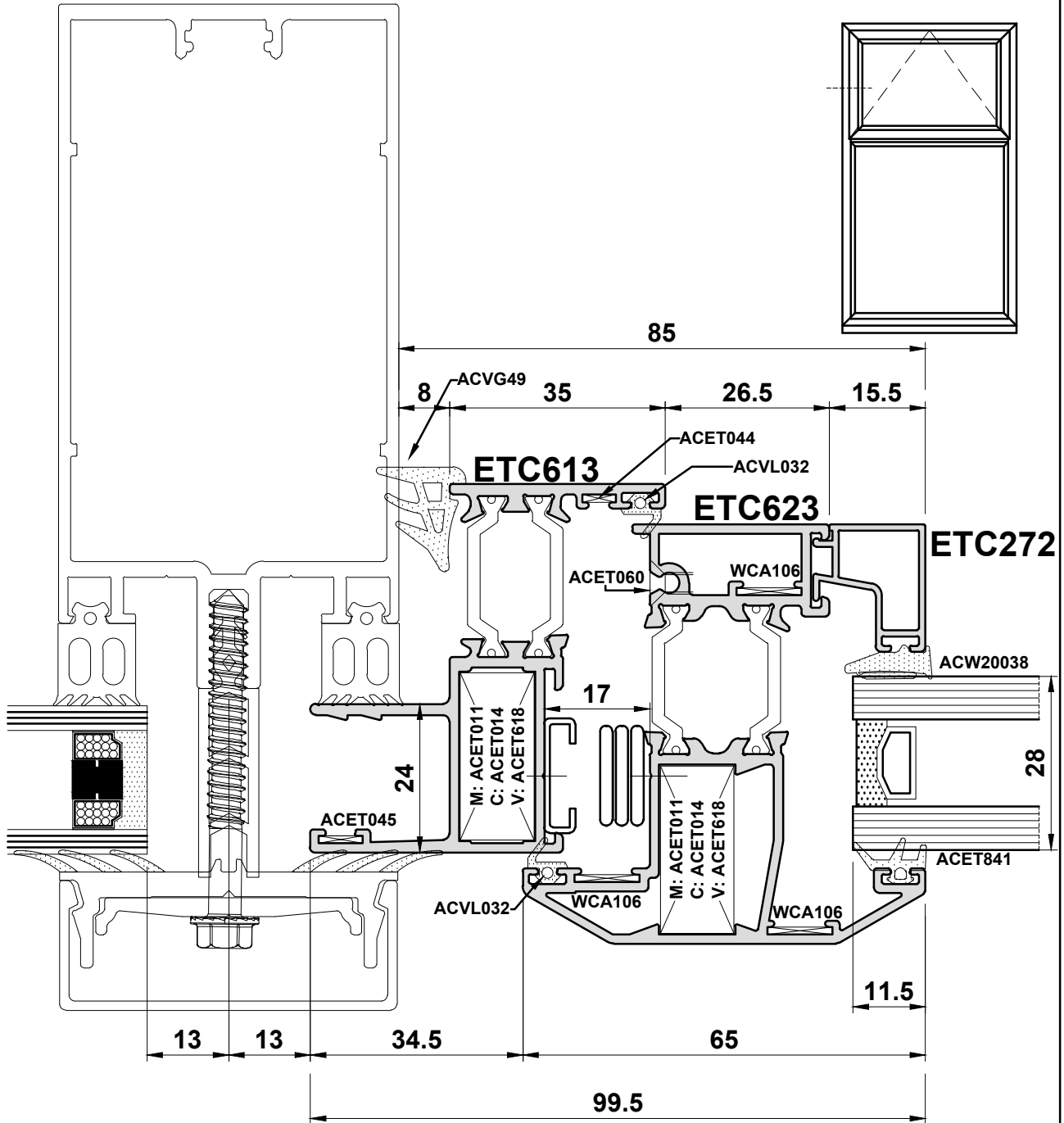
Do Not Scale From This Drawing

Detail 2G



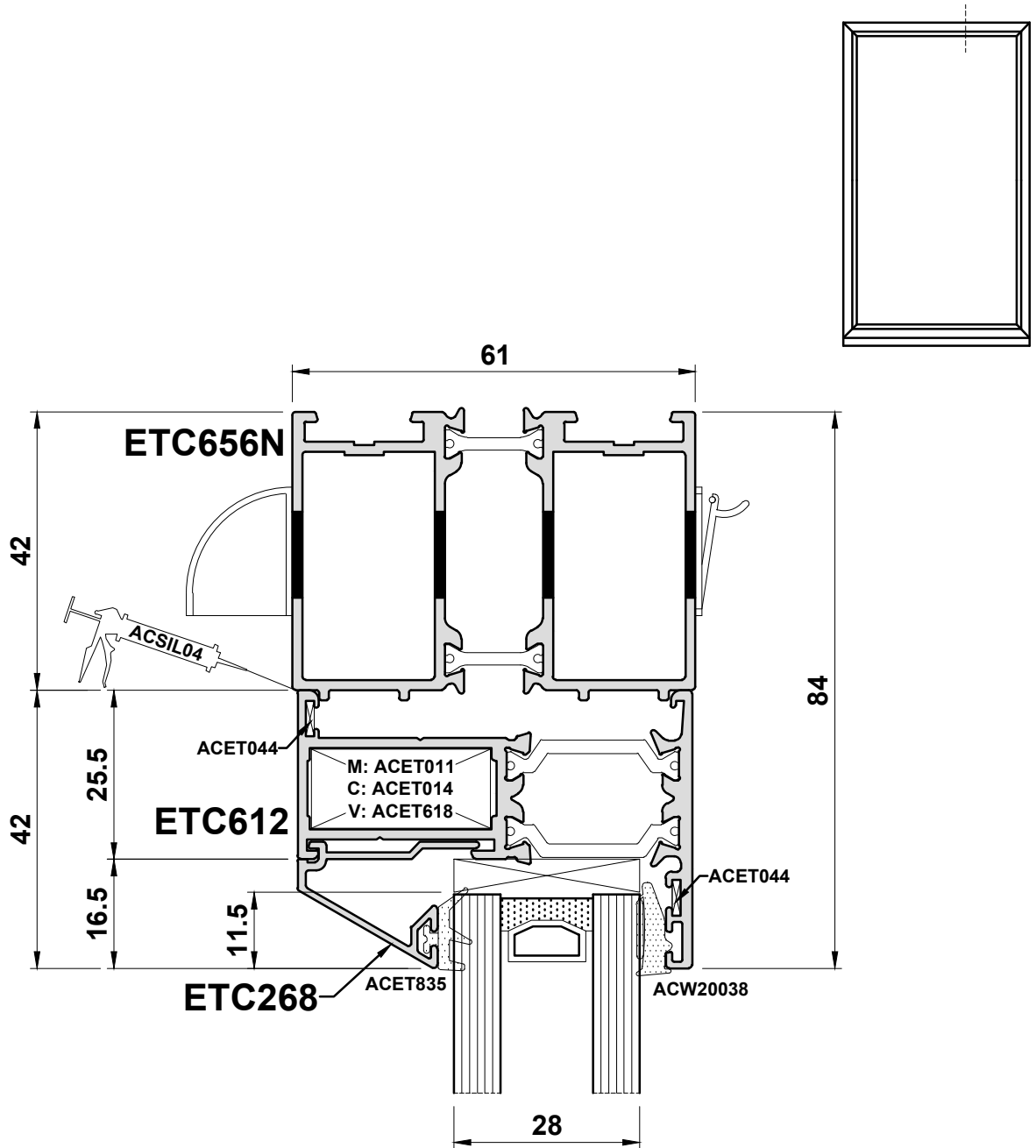
Do Not Scale From This Drawing

Detail 2H



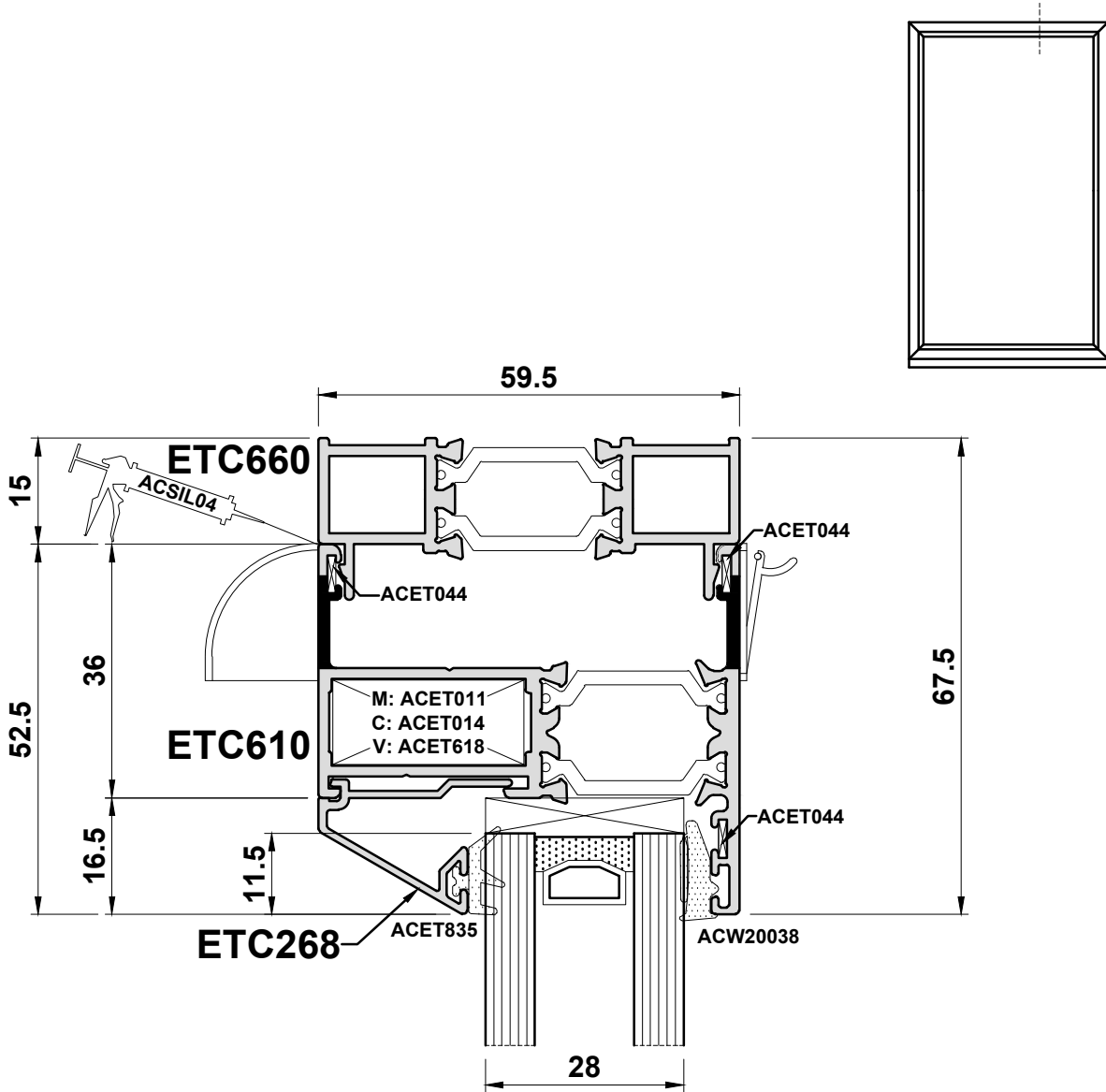
Do Not Scale From This Drawing

Detail 3A



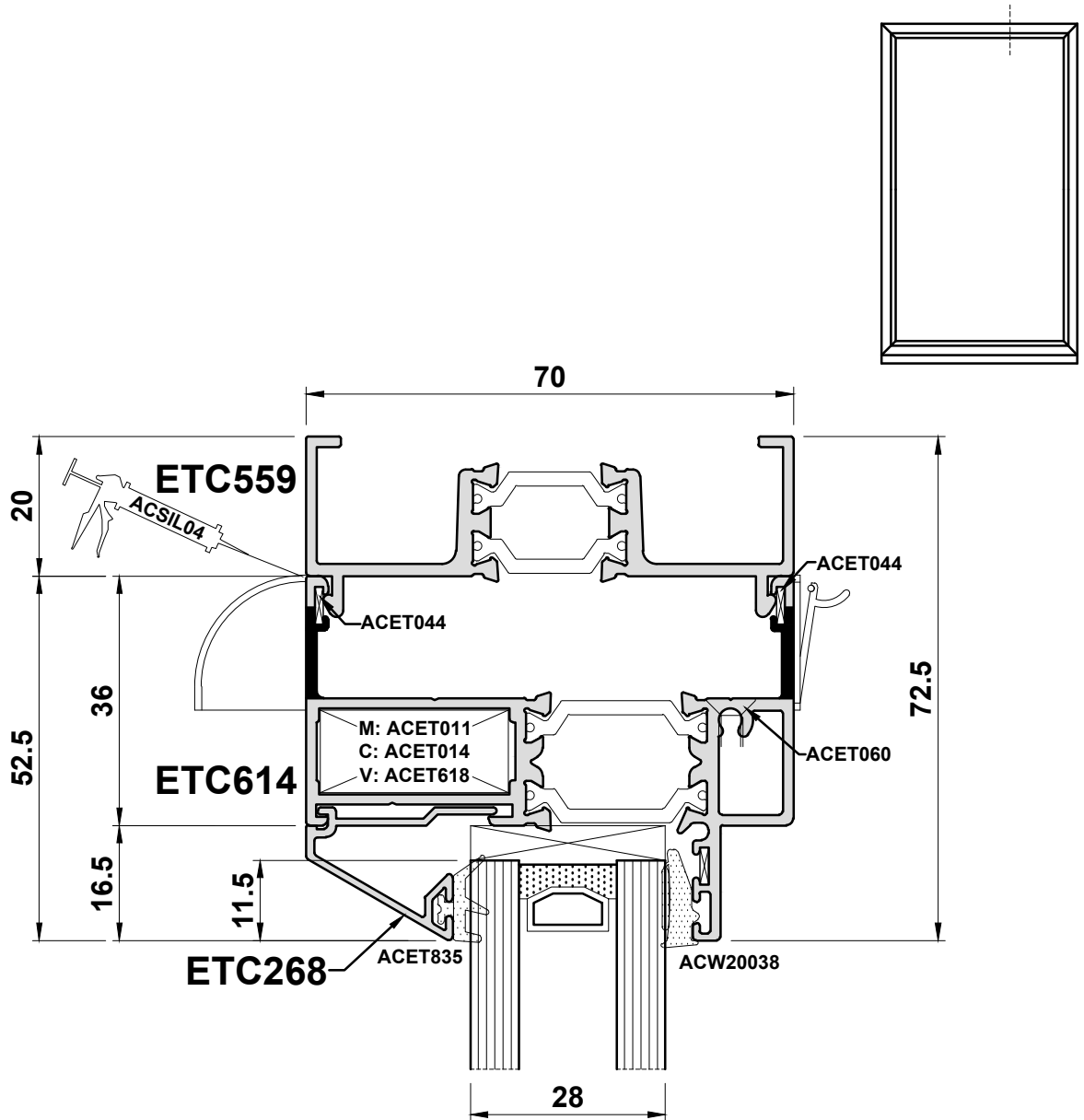
Do Not Scale From This Drawing

Detail 3B



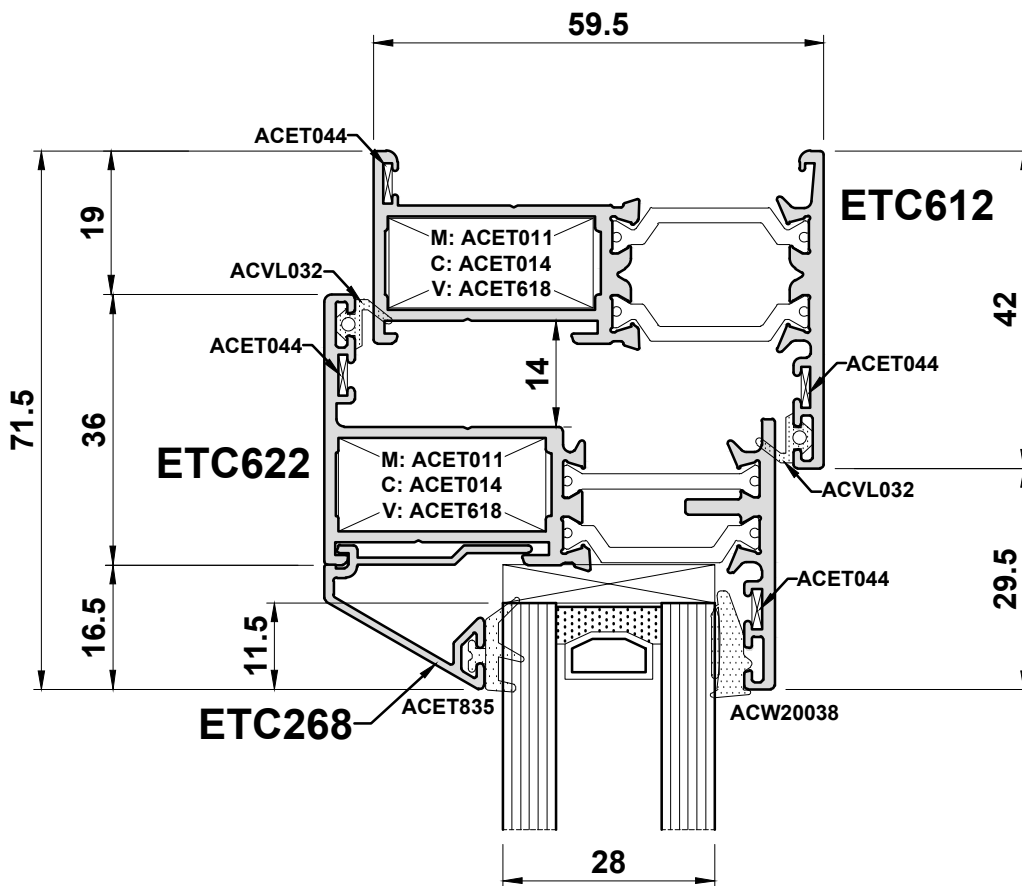
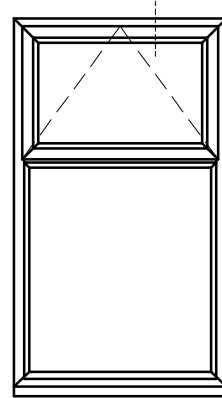
Do Not Scale From This Drawing

Detail 3C



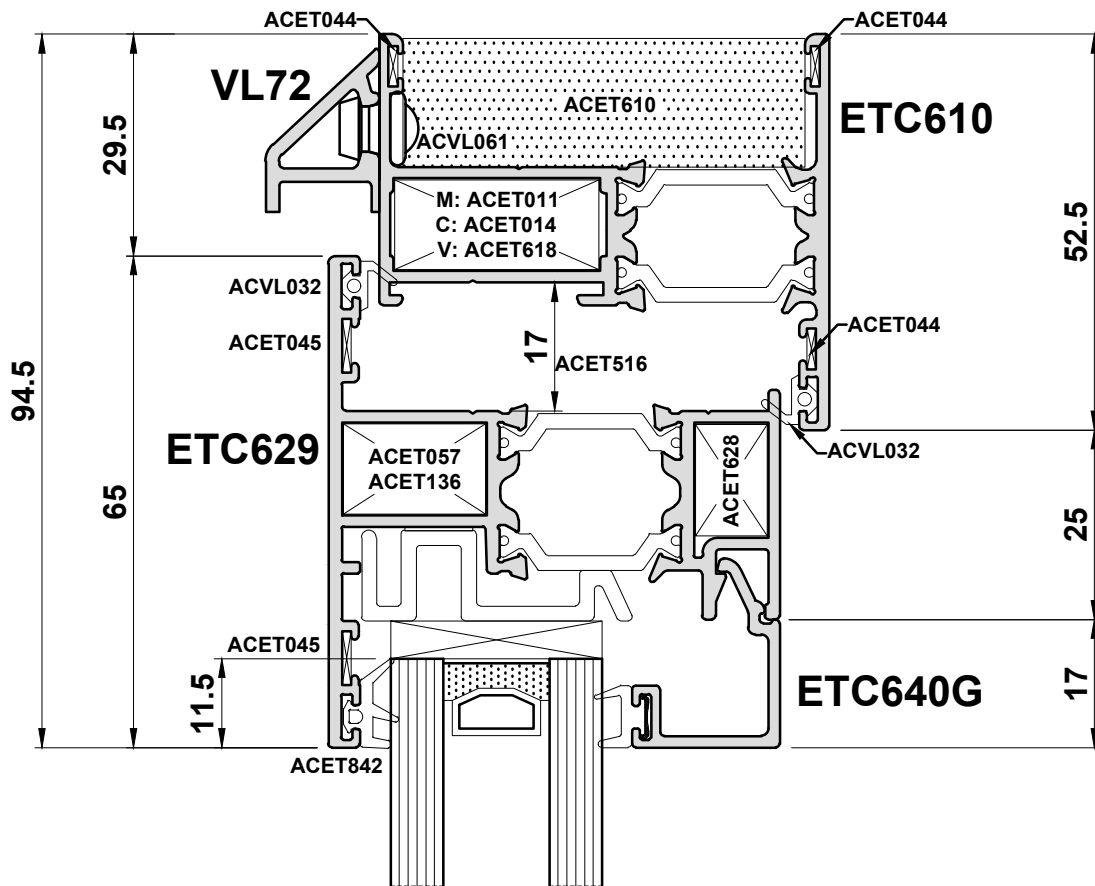
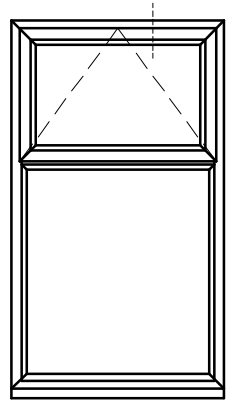
Do Not Scale From This Drawing

Detail 4A



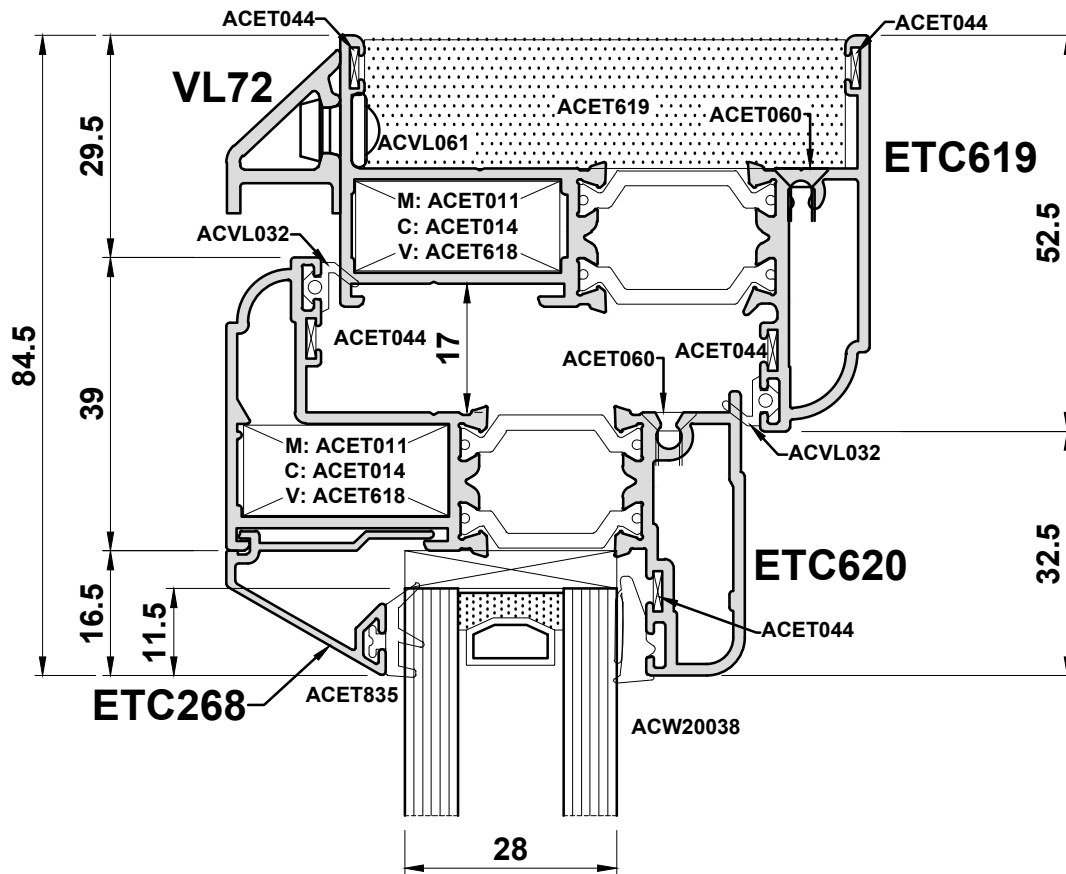
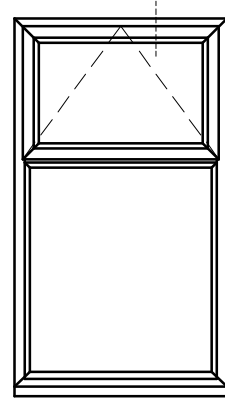
Do Not Scale From This Drawing

Detail 4B



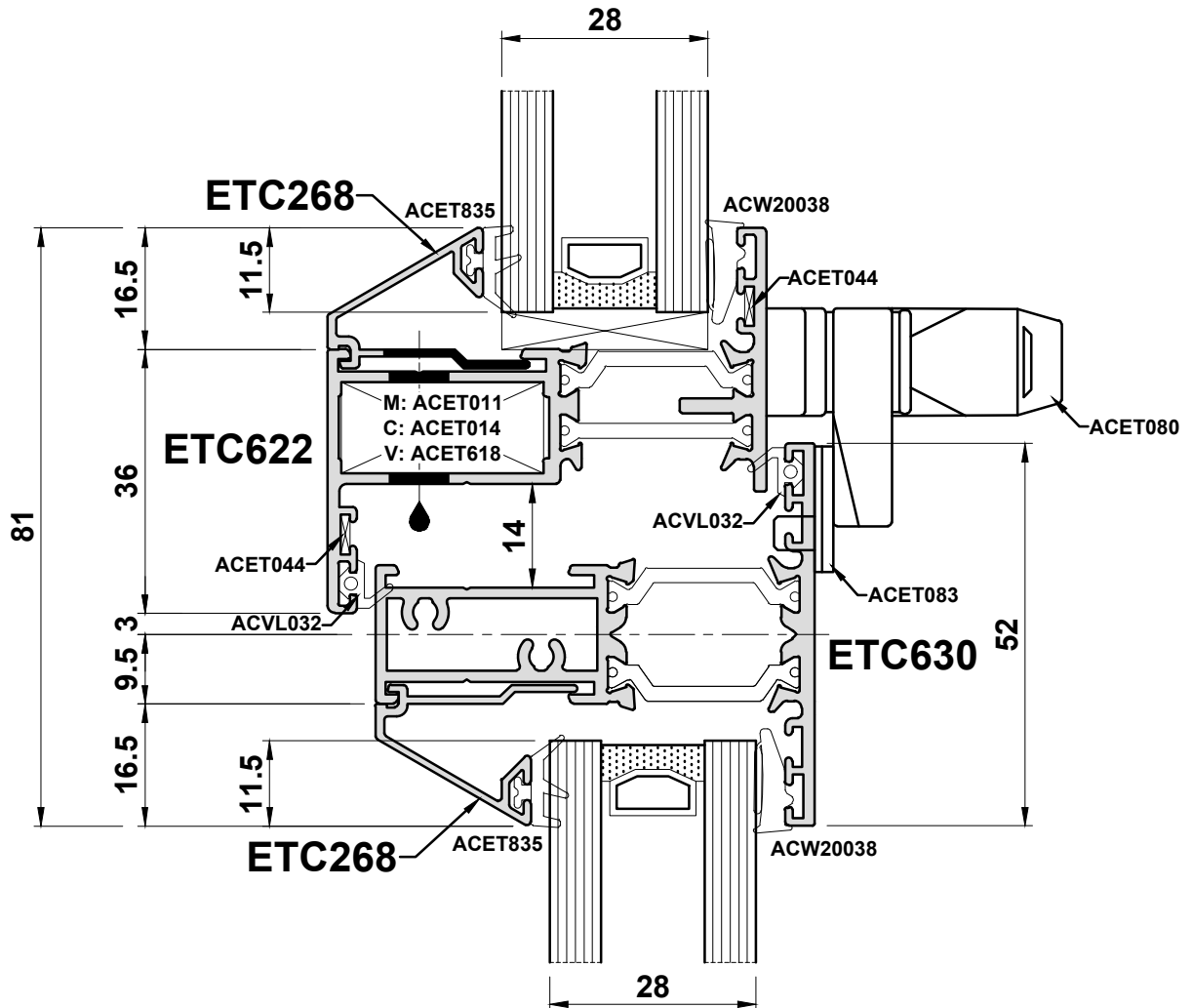
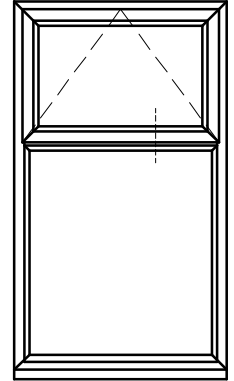
Do Not Scale From This Drawing

Detail 4C



Do Not Scale From This Drawing

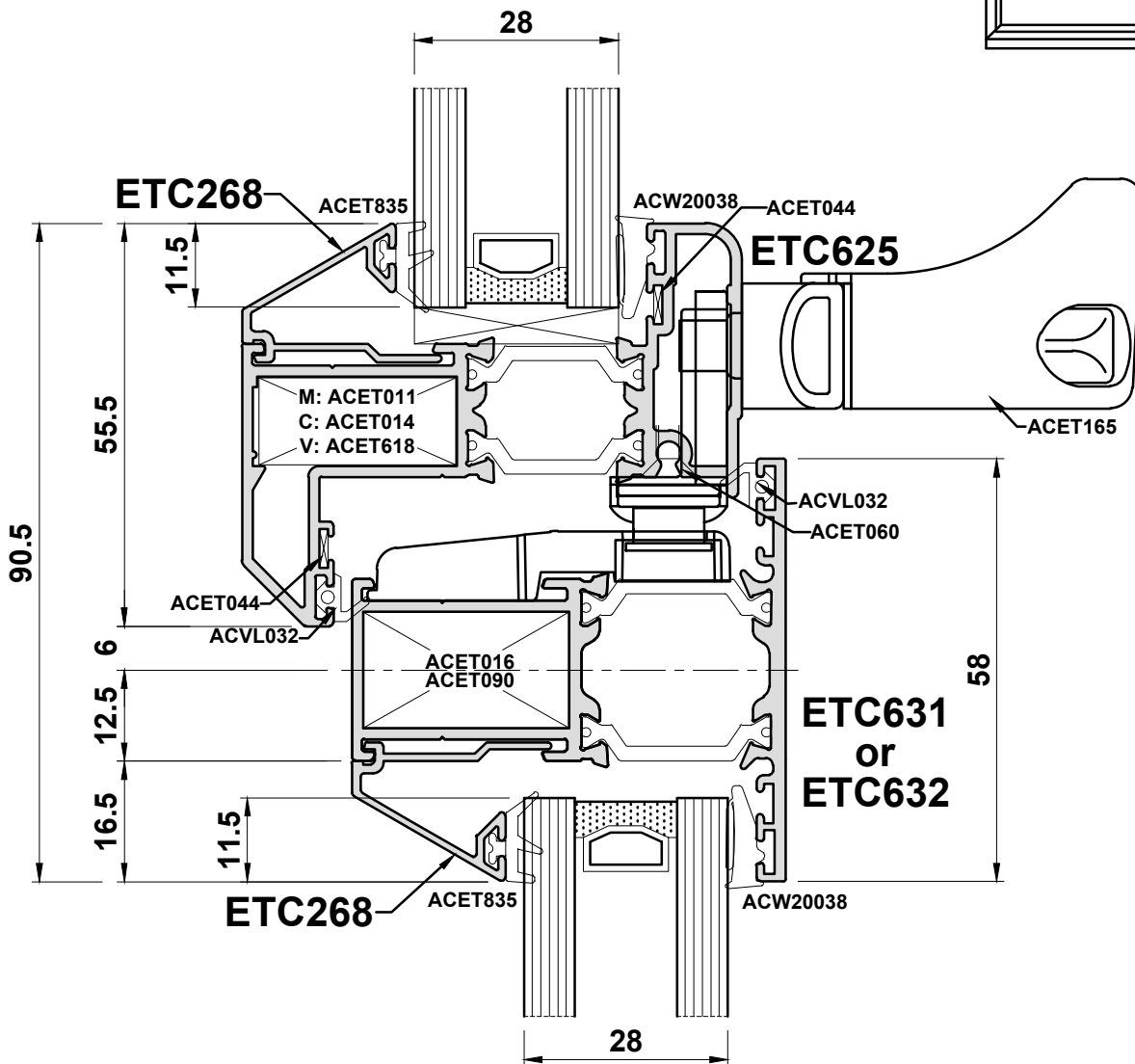
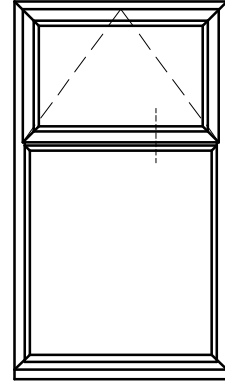
Detail 5A



Note: Transoms will drain through the join to the outerframe.

Do Not Scale From This Drawing

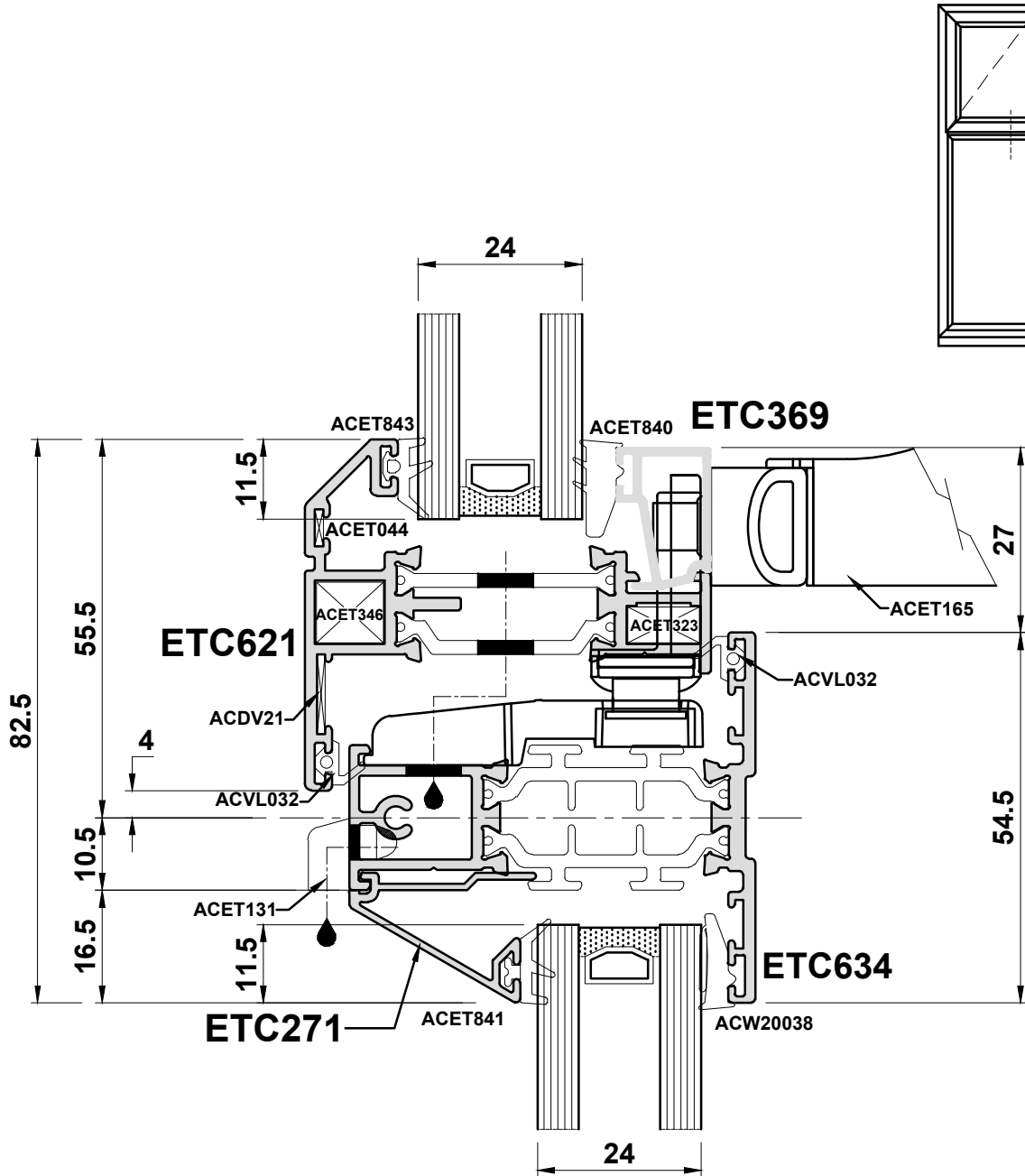
Detail 5B



Note: Transoms will drain through the join to the outerframe.

Do Not Scale From This Drawing

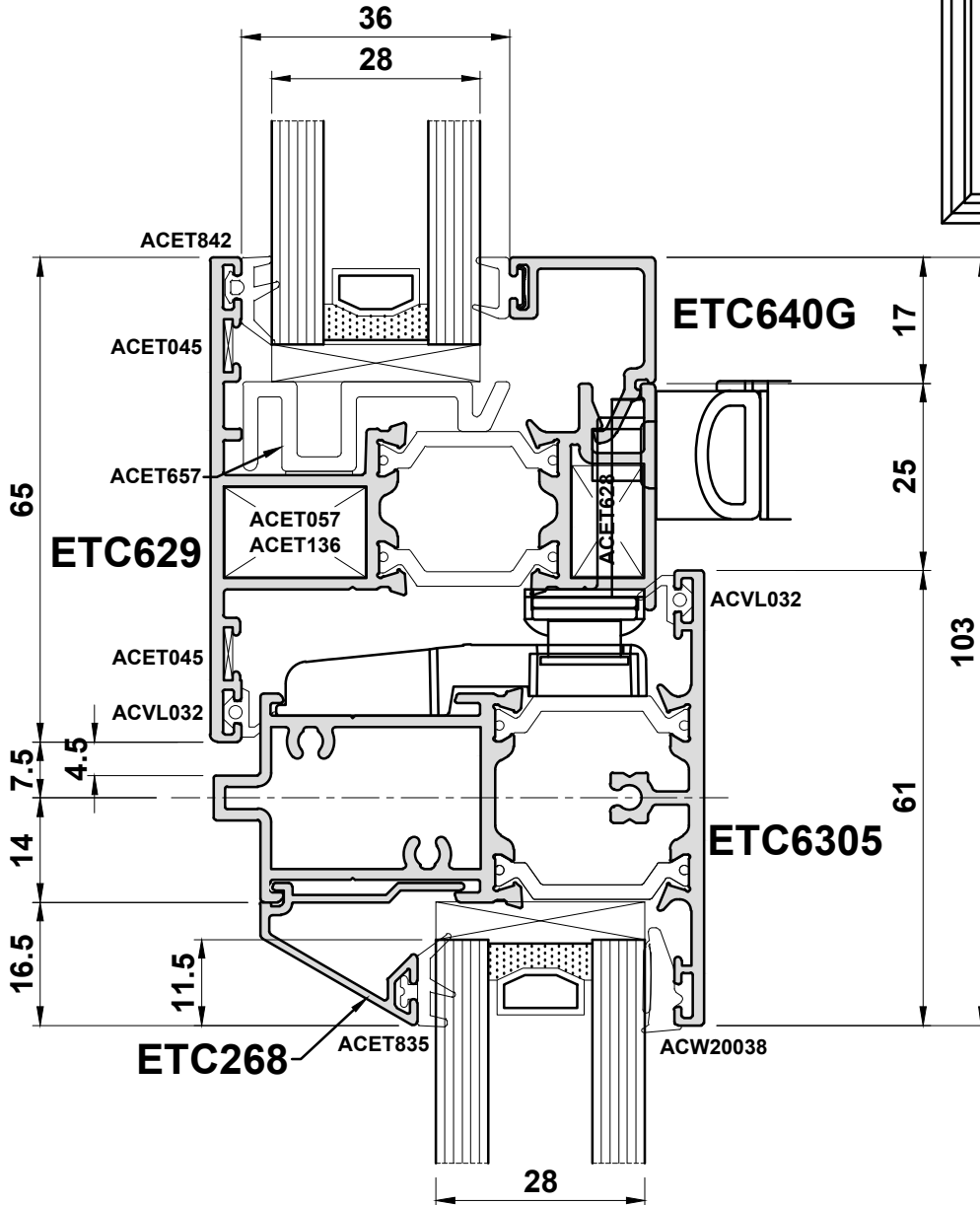
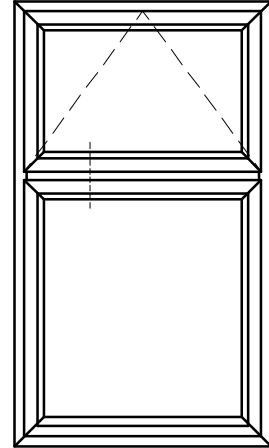
Detail 5C



Note: Transoms will drain through the join to the outerframe.

Do Not Scale From This Drawing

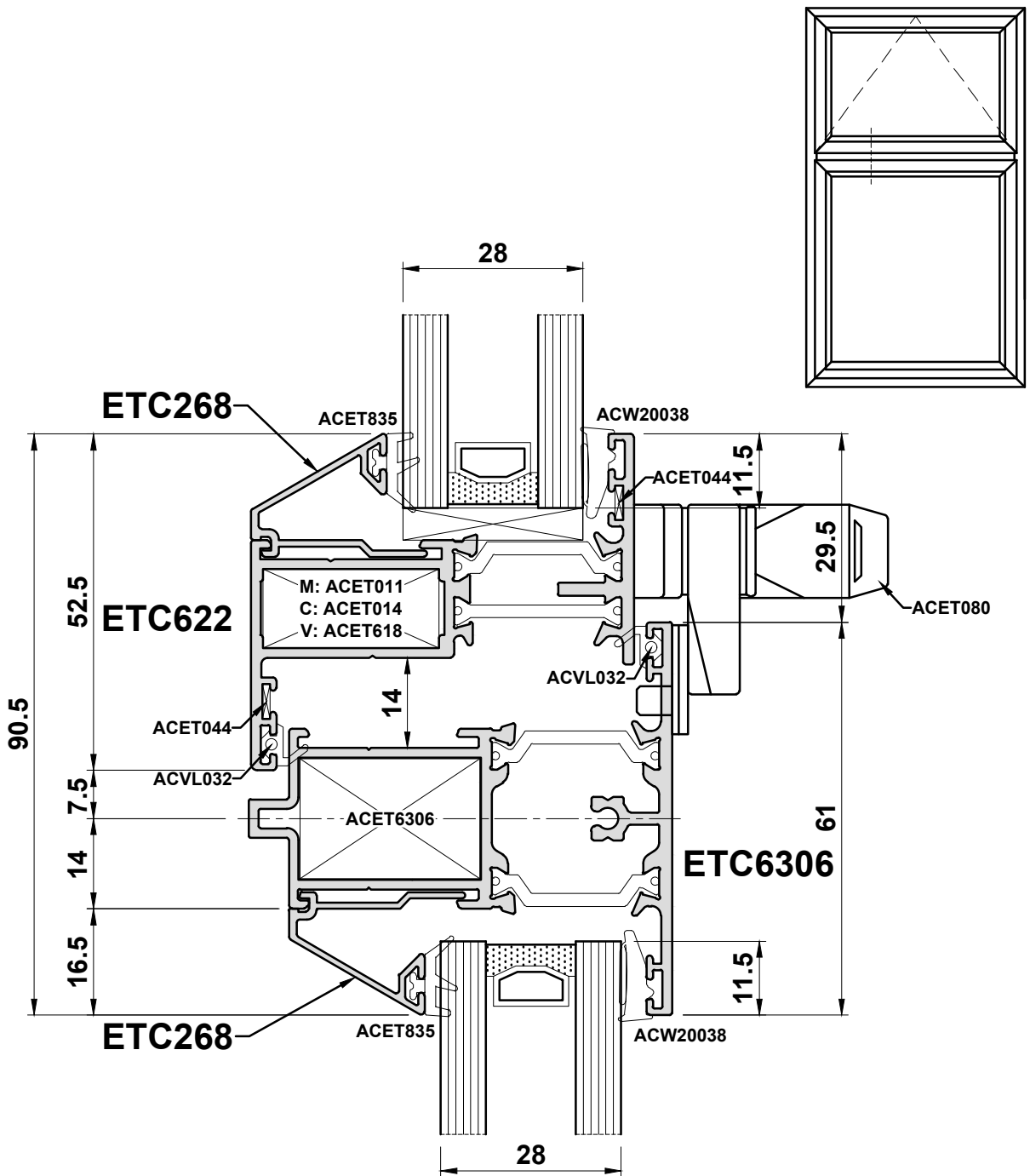
Detail 5D



Note: Transoms will drain through the join to the outerframe.

Do Not Scale From This Drawing

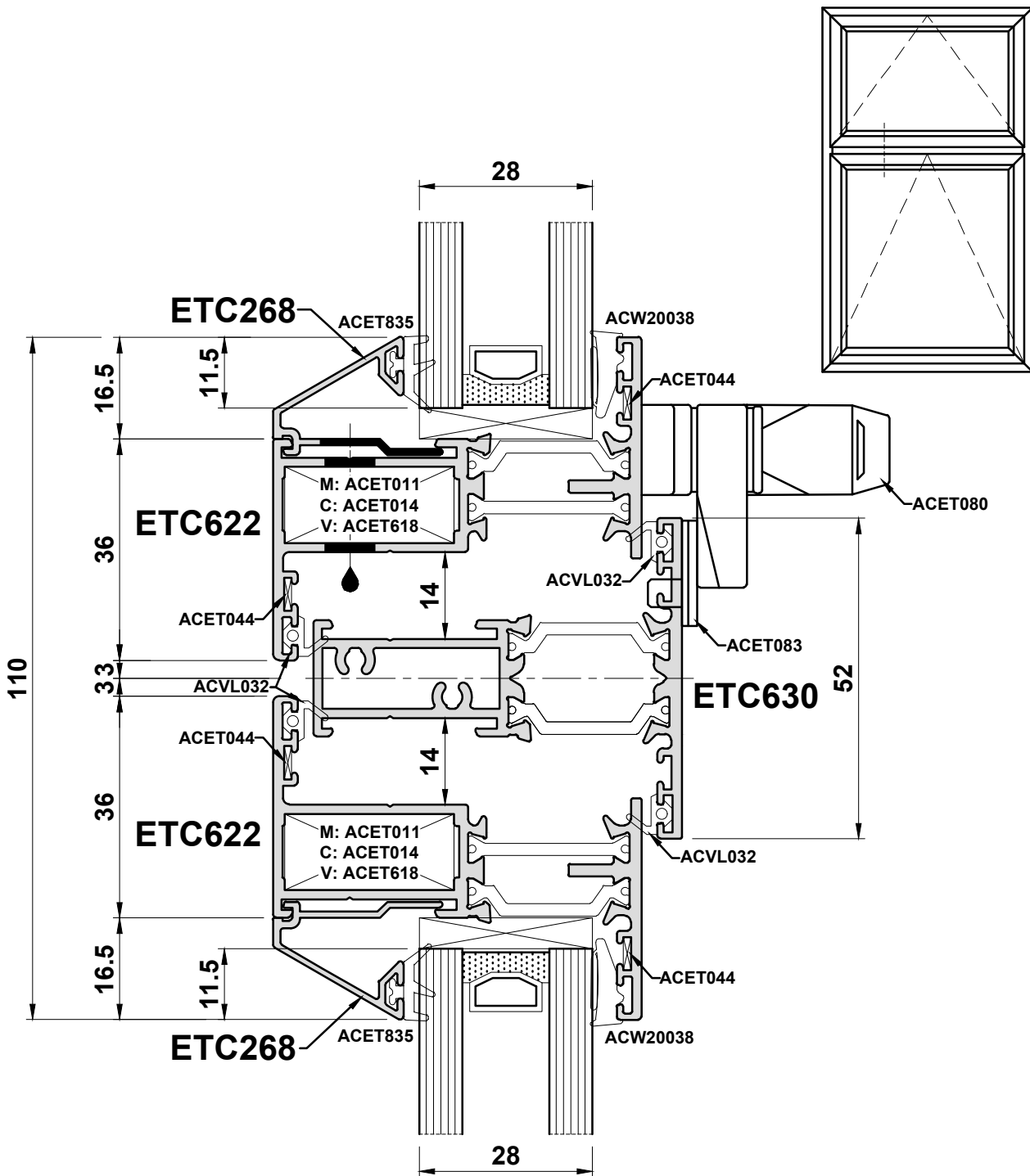
Detail 5E



Note: Transoms will drain through the joint to the outerframe.

Do Not Scale From This Drawing

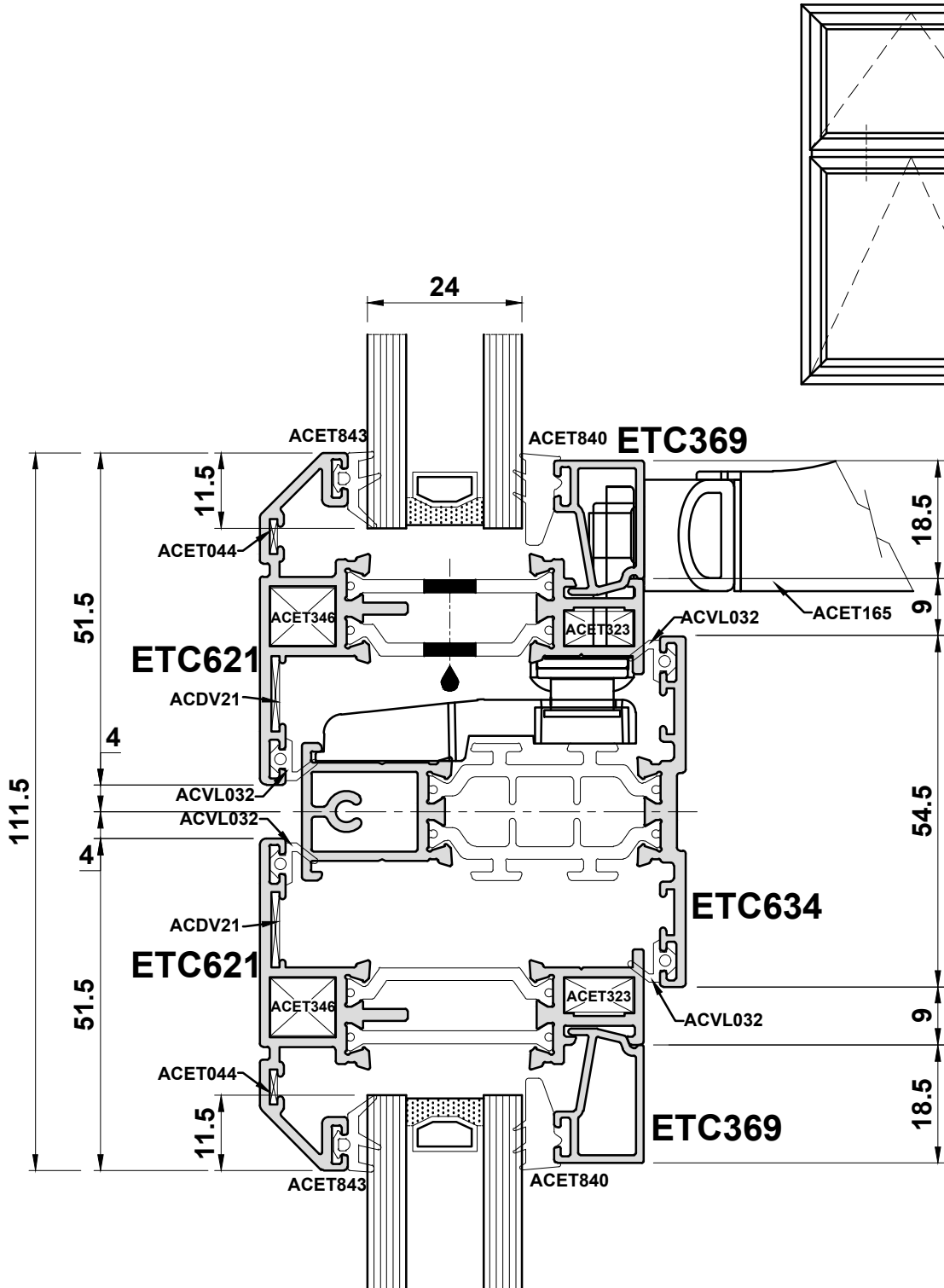
Detail 6A



Note: Transoms will drain through the join to the outerframe.

Do Not Scale From This Drawing

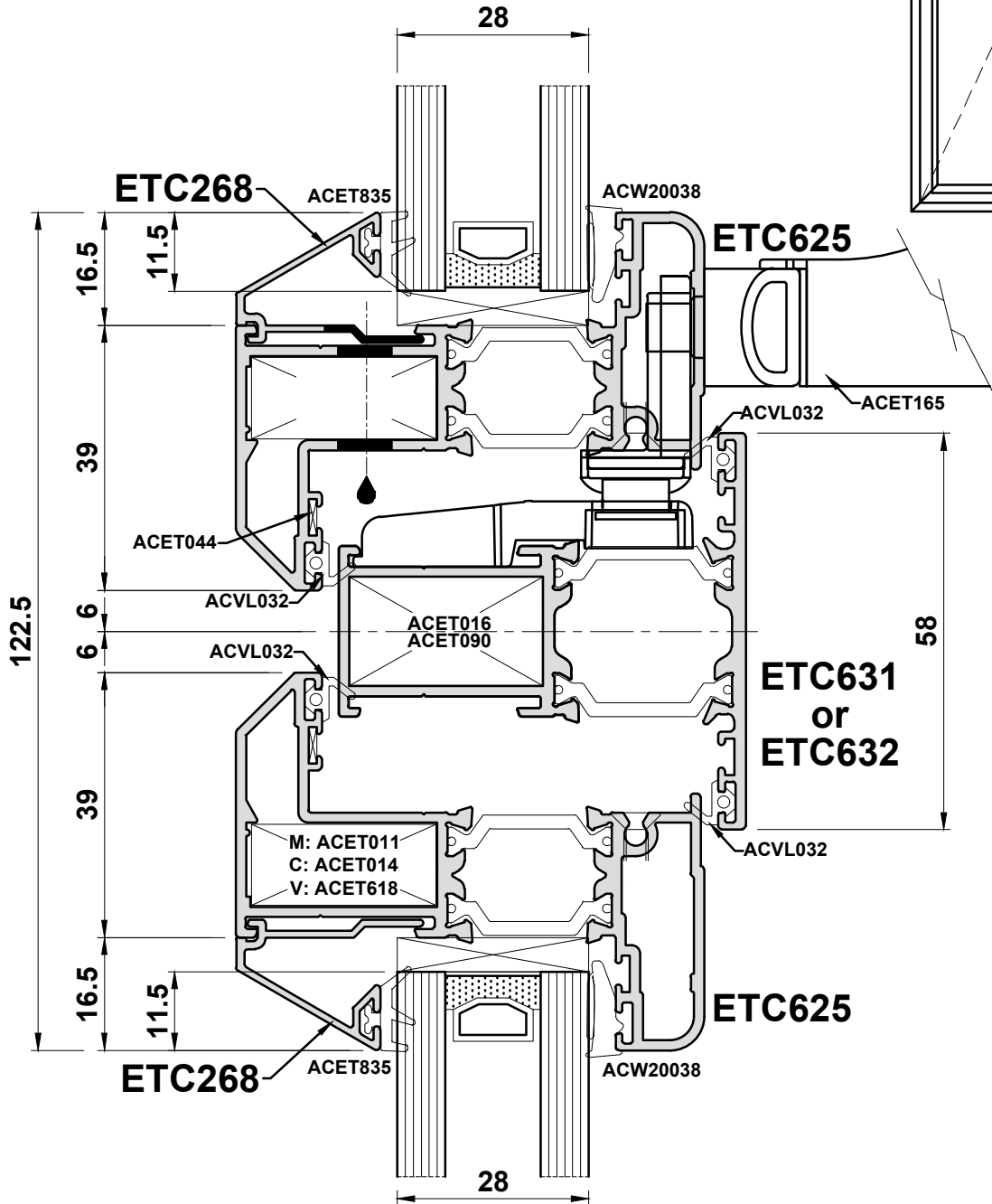
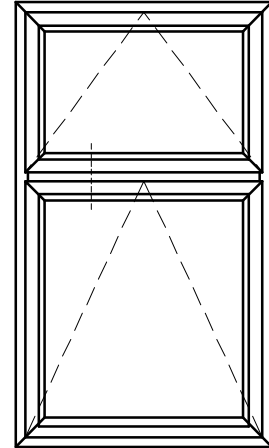
Detail 6B



Note: Transoms will drain through the join to the outerframe.

Do Not Scale From This Drawing

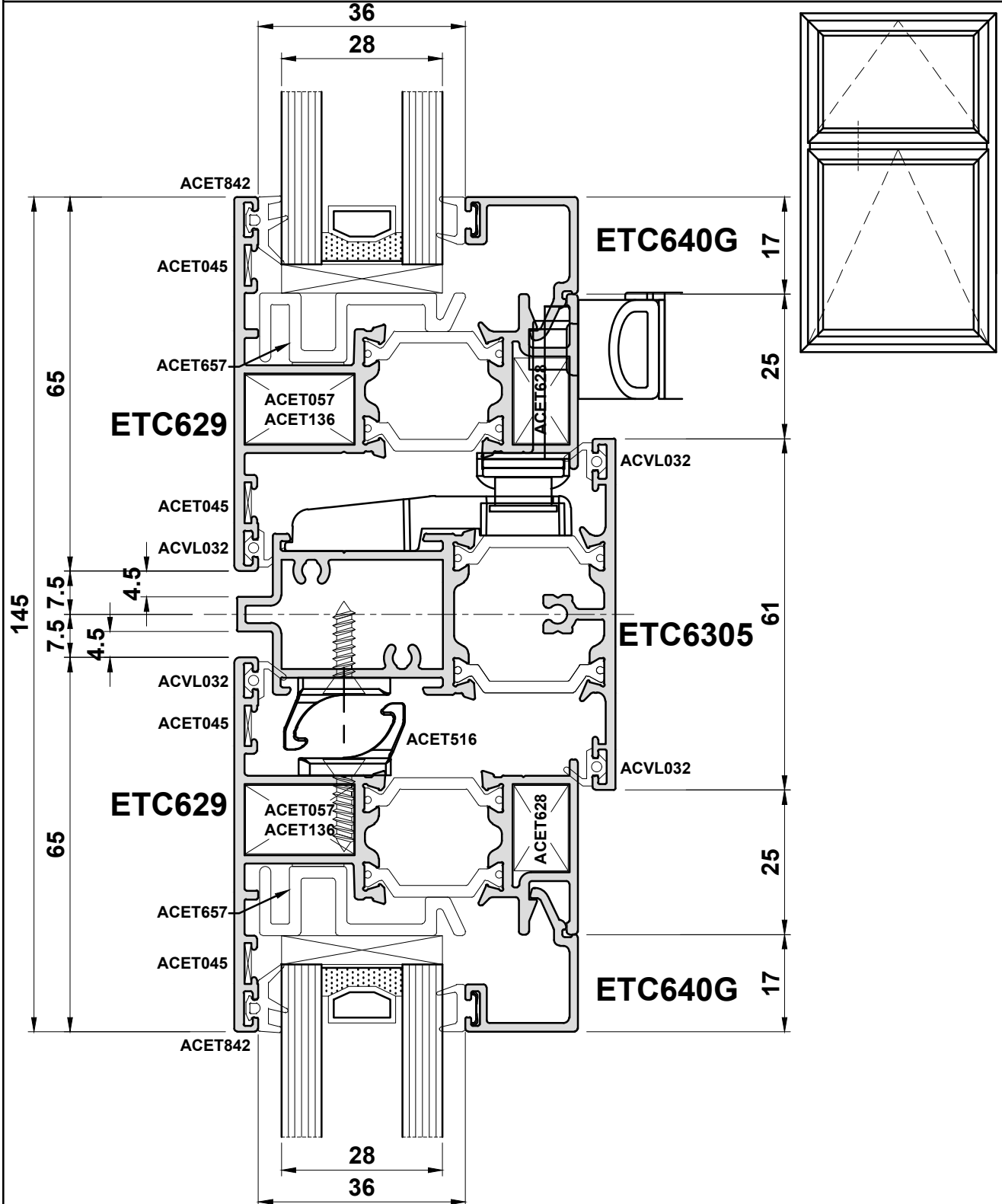
Detail 6C



Note: Transoms will drain through the join to the outerframe.

Do Not Scale From This Drawing

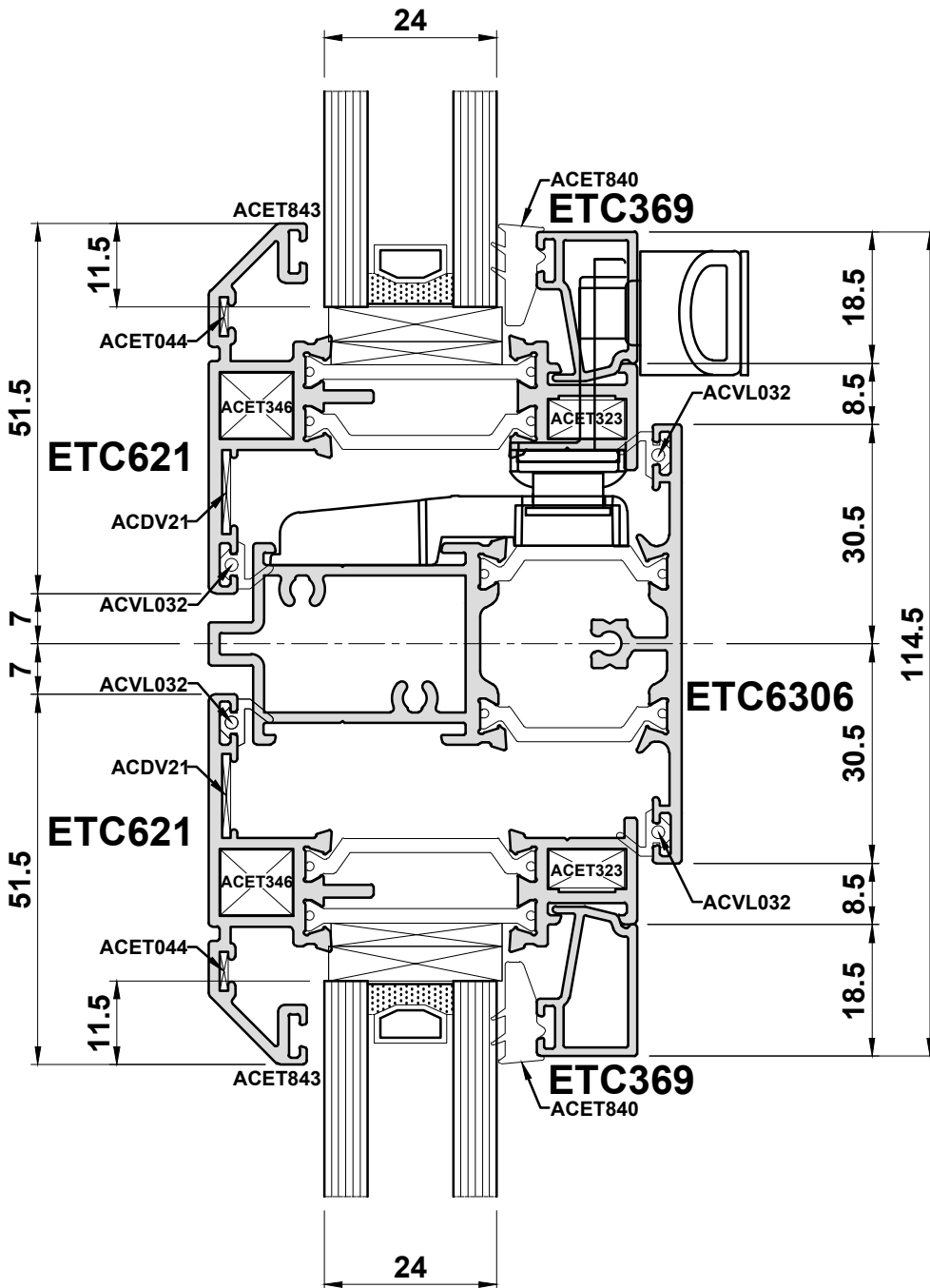
Detail 6D



Note: Transoms will drain through the join to the outerframe.

Do Not Scale From This Drawing

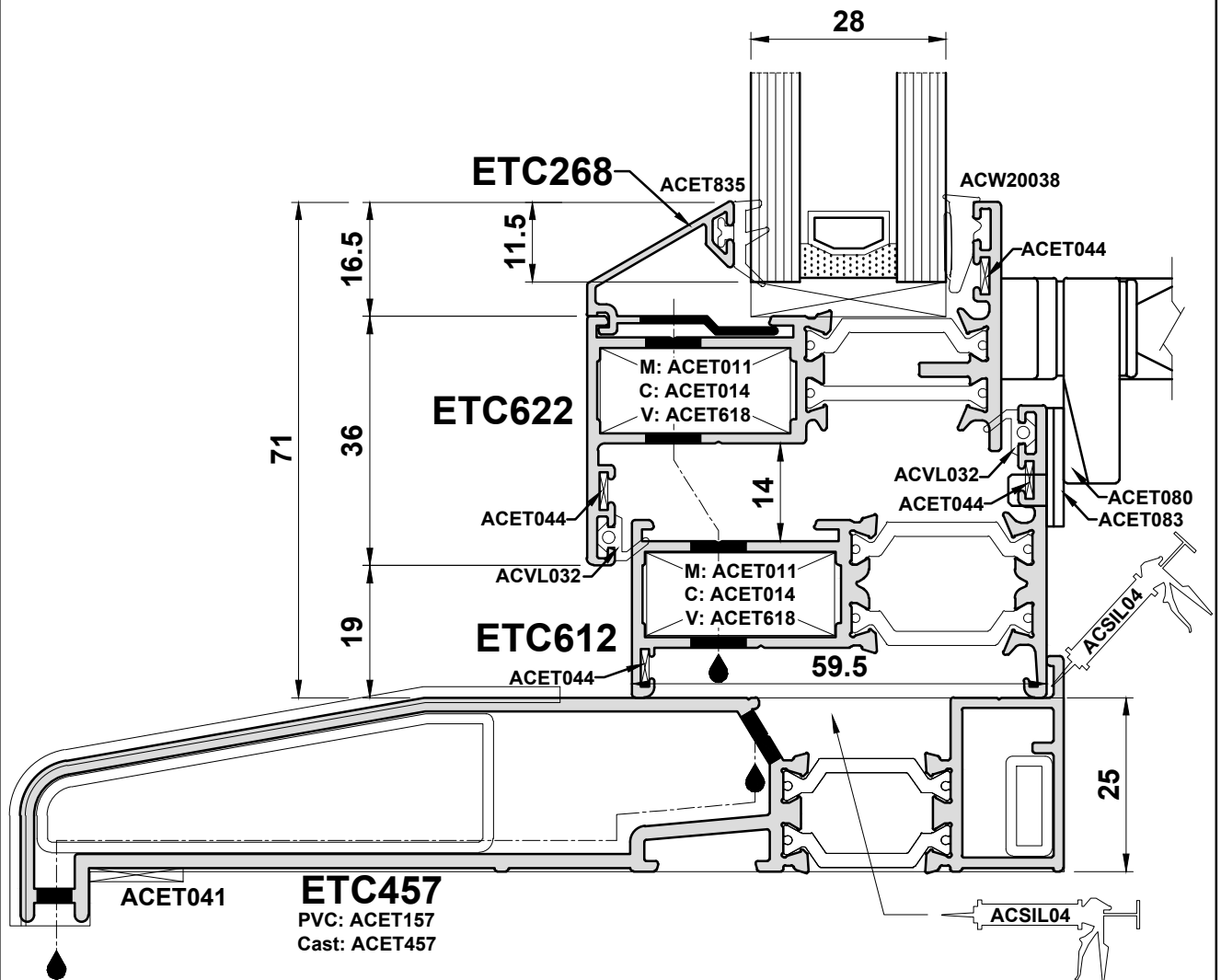
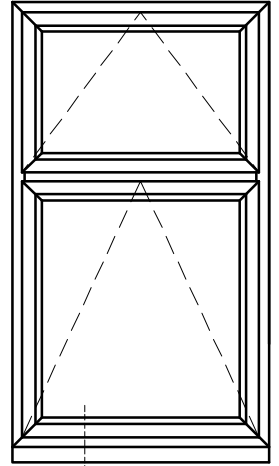
Detail 6E



Note: Transoms will drain through the join to the outerframe.

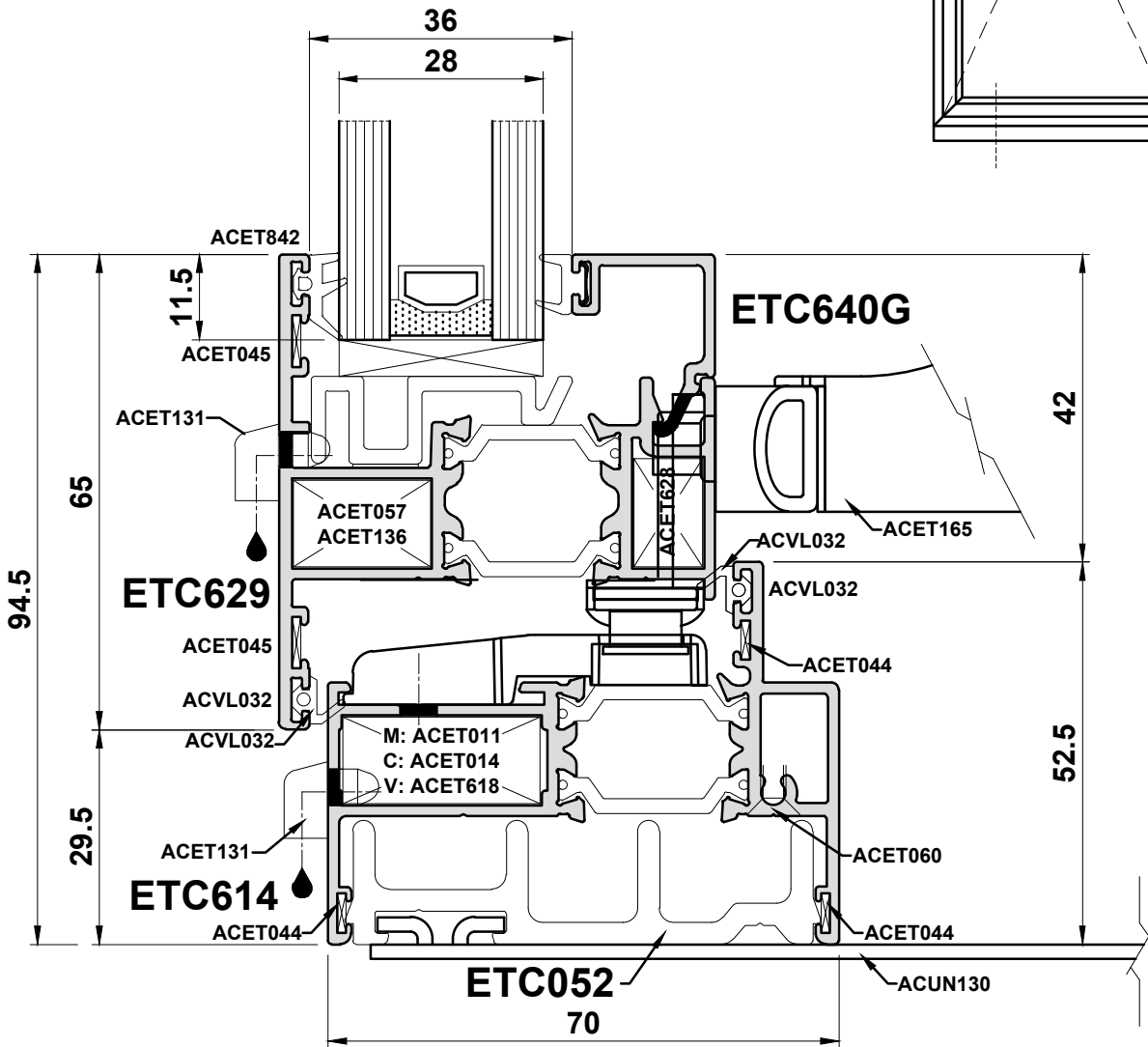
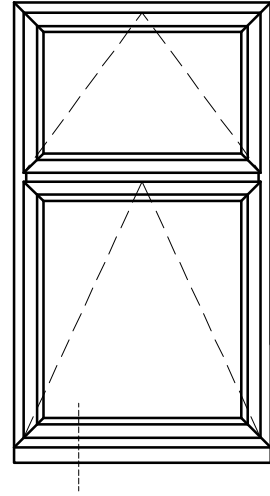
Do Not Scale From This Drawing

Detail 7A



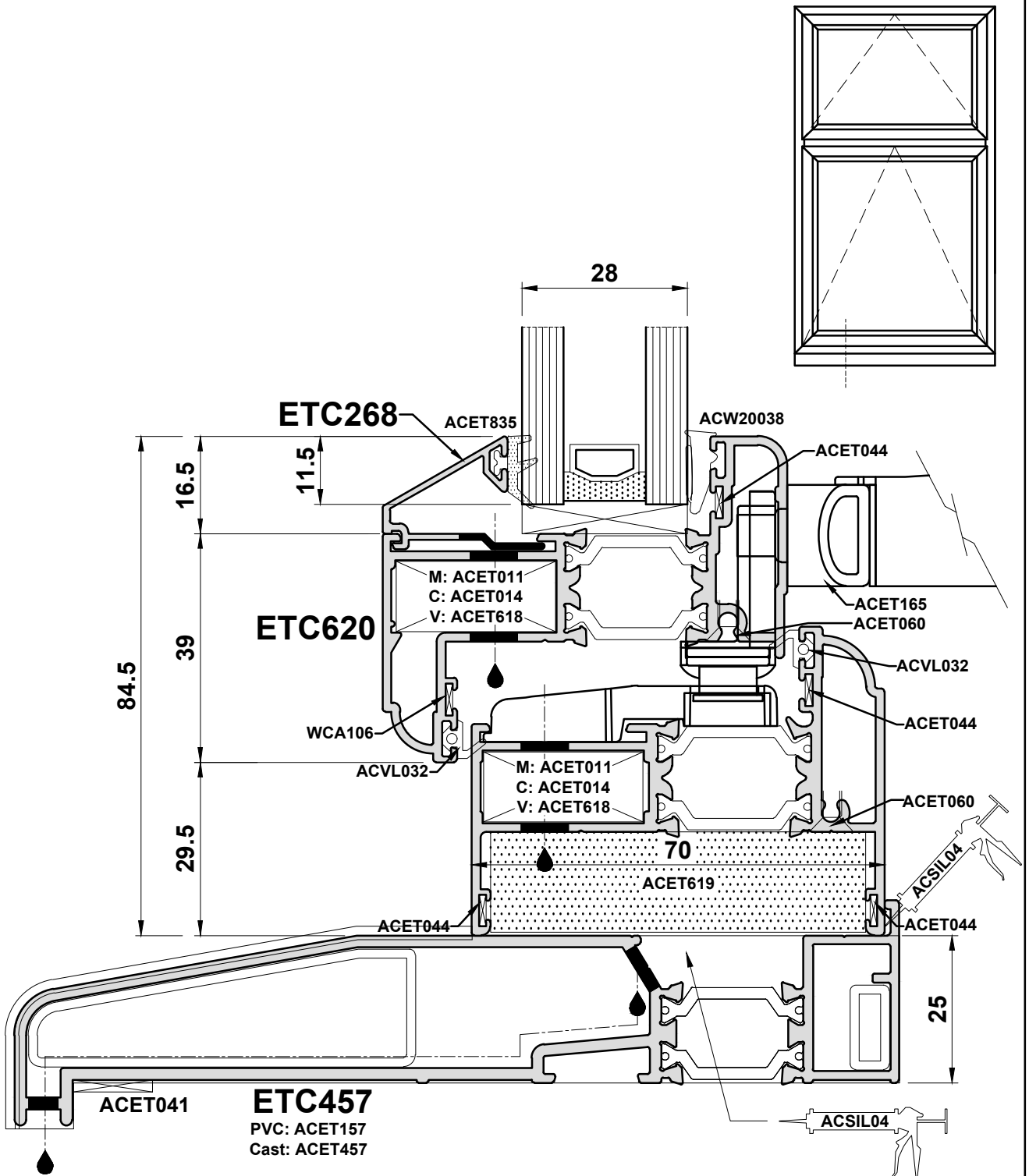
Do Not Scale From This Drawing

Detail 7B



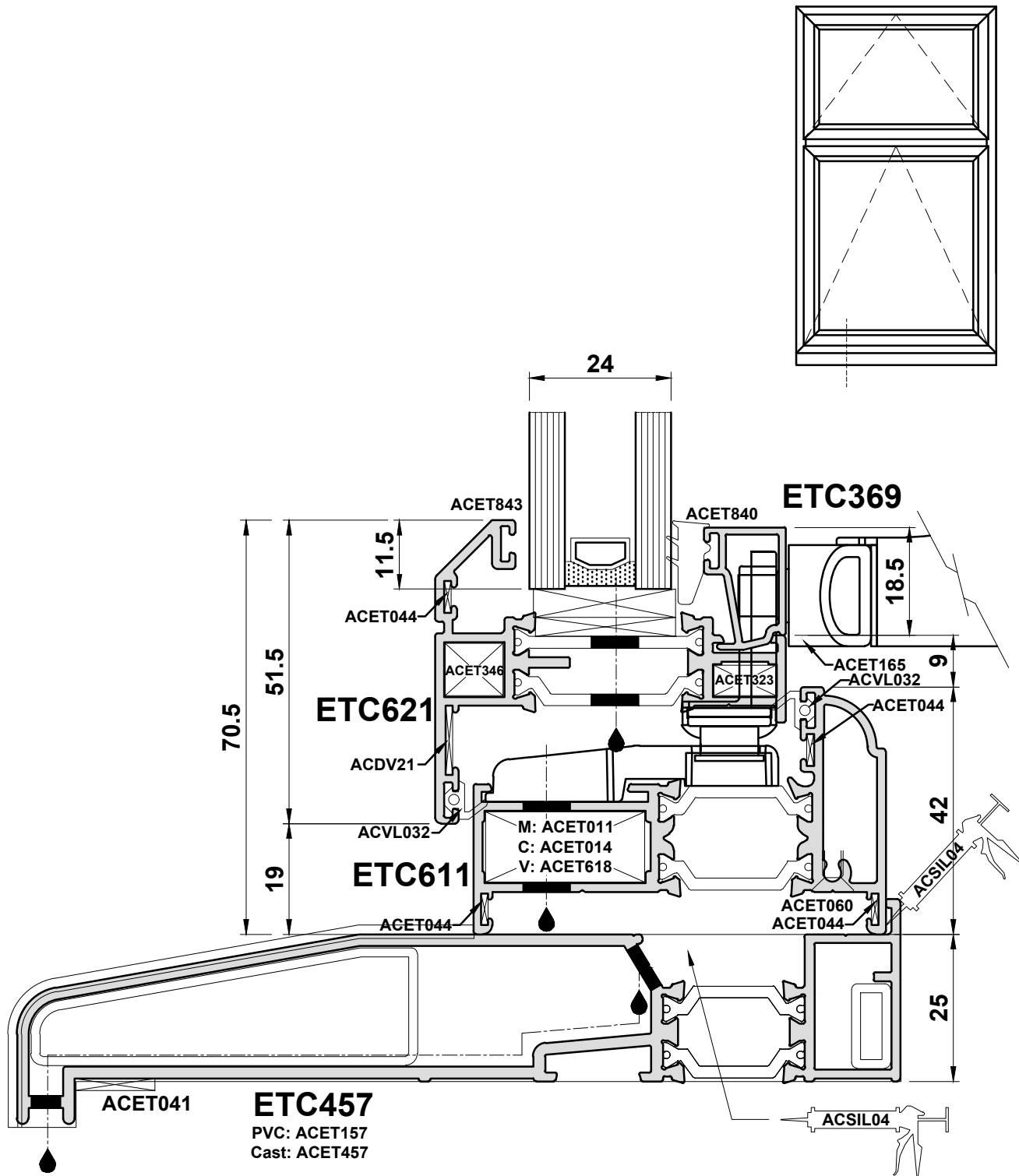
Do Not Scale From This Drawing

Detail 7C



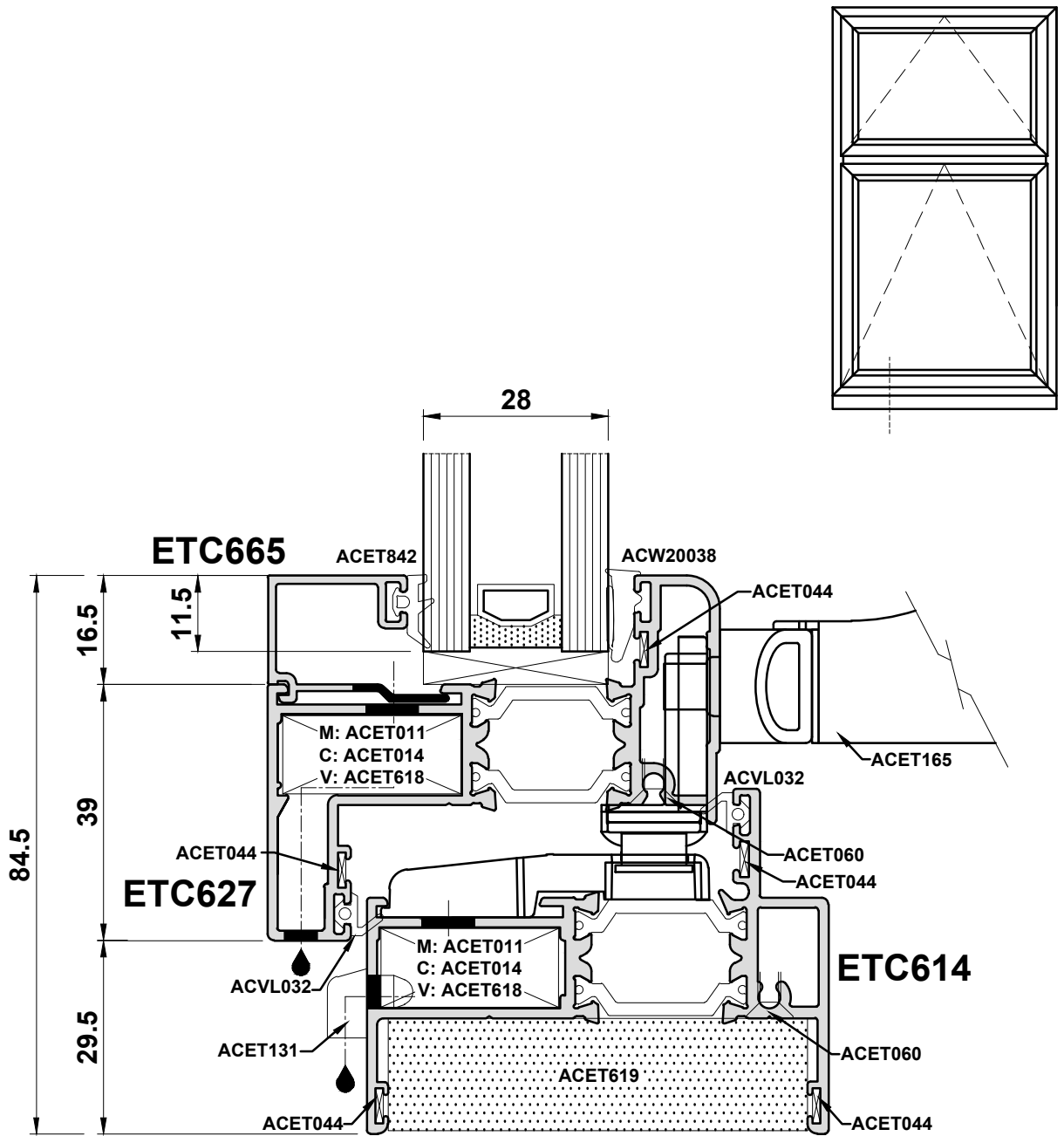
Do Not Scale From This Drawing

Detail 7D



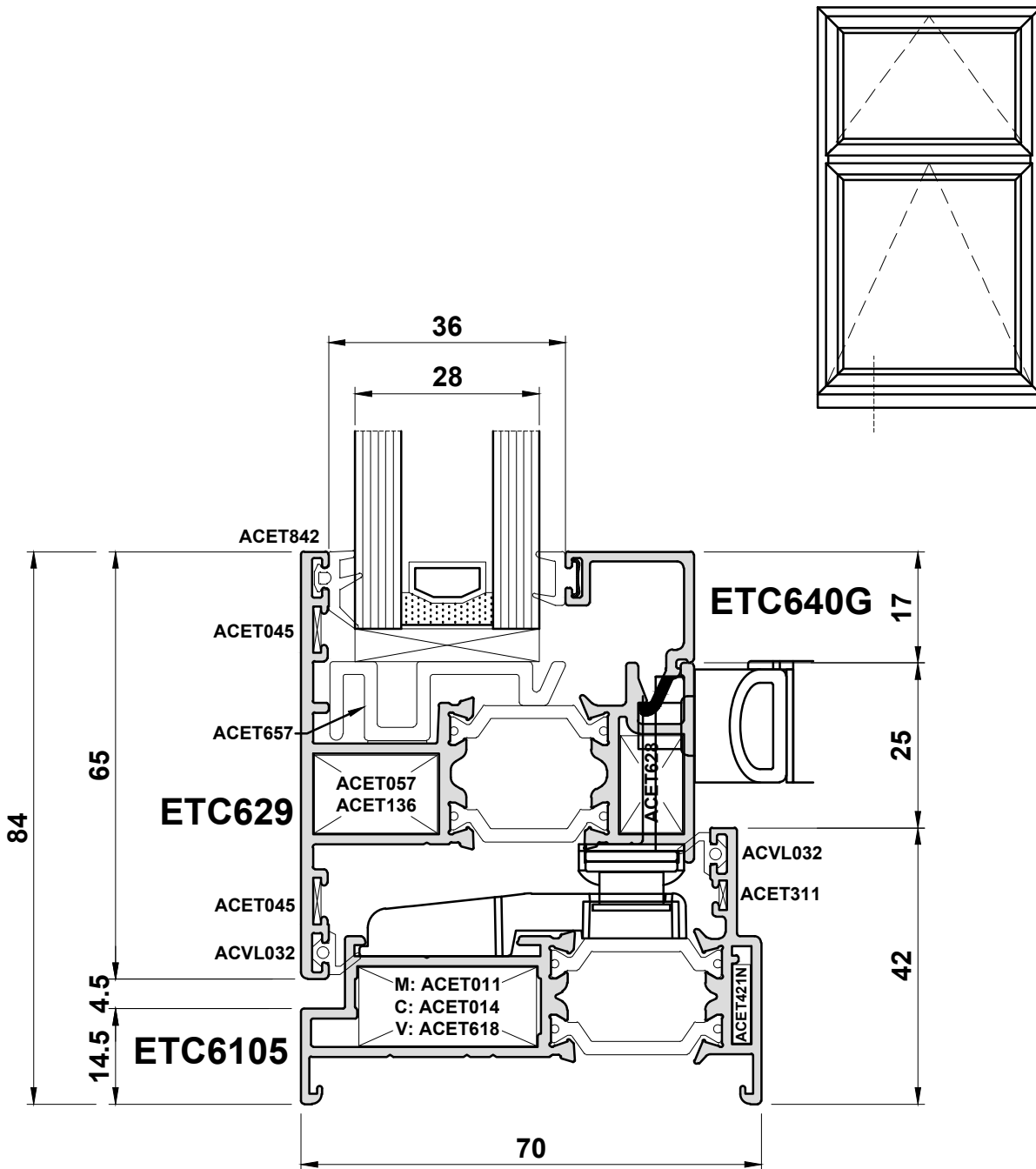
Do Not Scale From This Drawing

Detail 7E



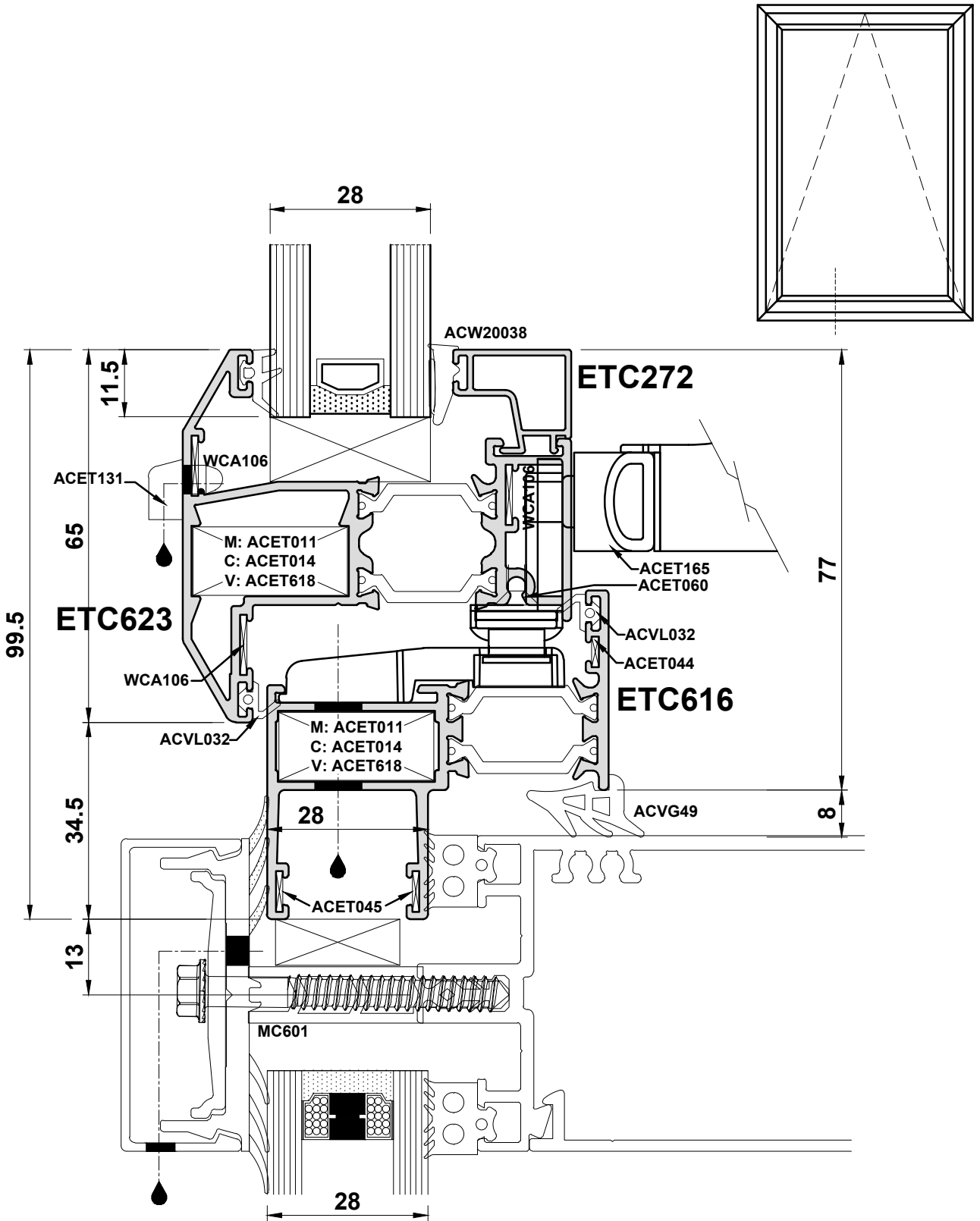
Do Not Scale From This Drawing

Detail 7F



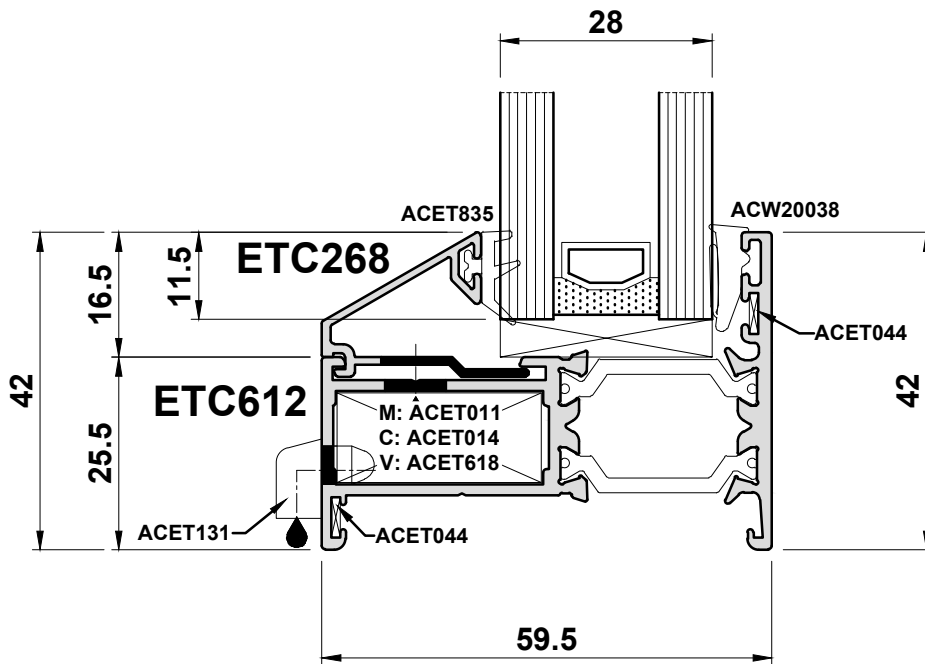
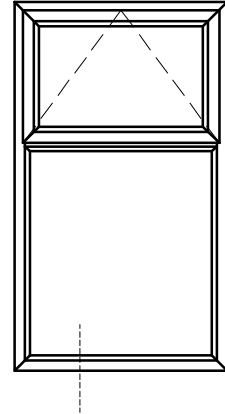
Do Not Scale From This Drawing

Detail 7G



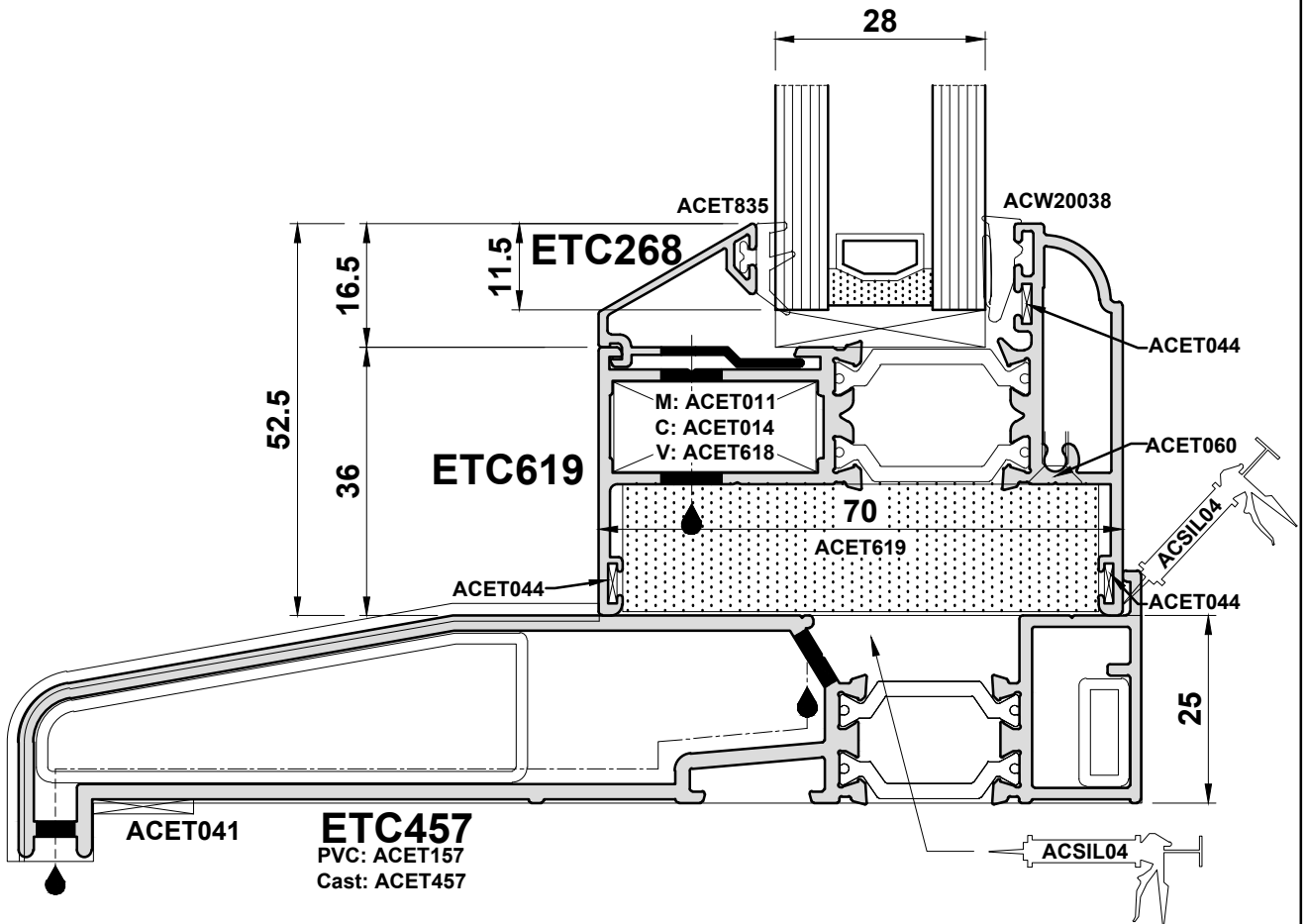
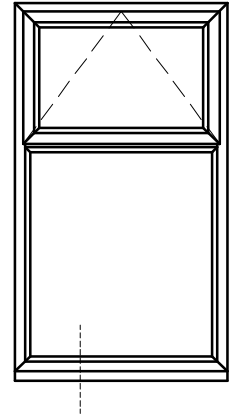
Do Not Scale From This Drawing

Detail 8A



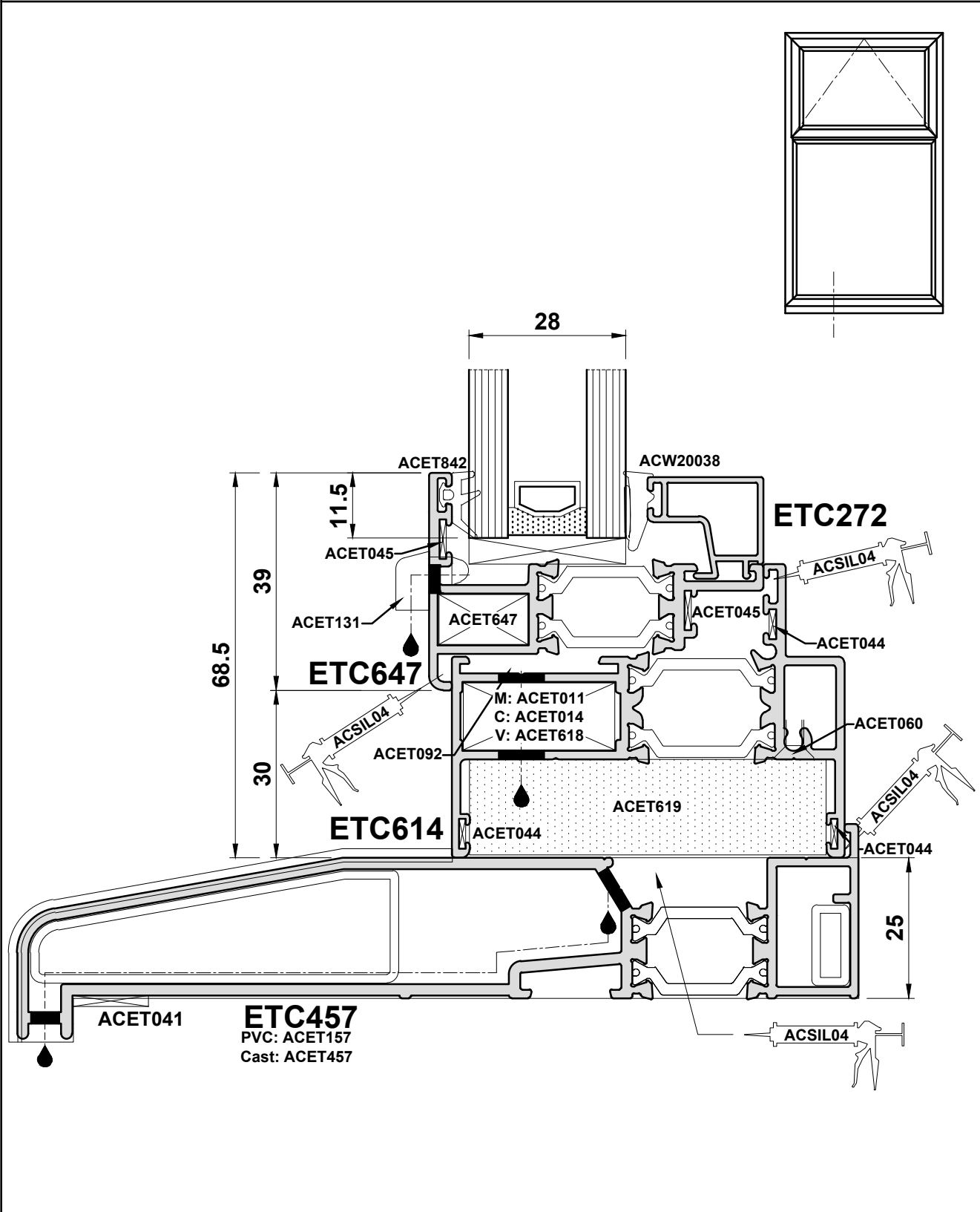
Do Not Scale From This Drawing

Detail 8B



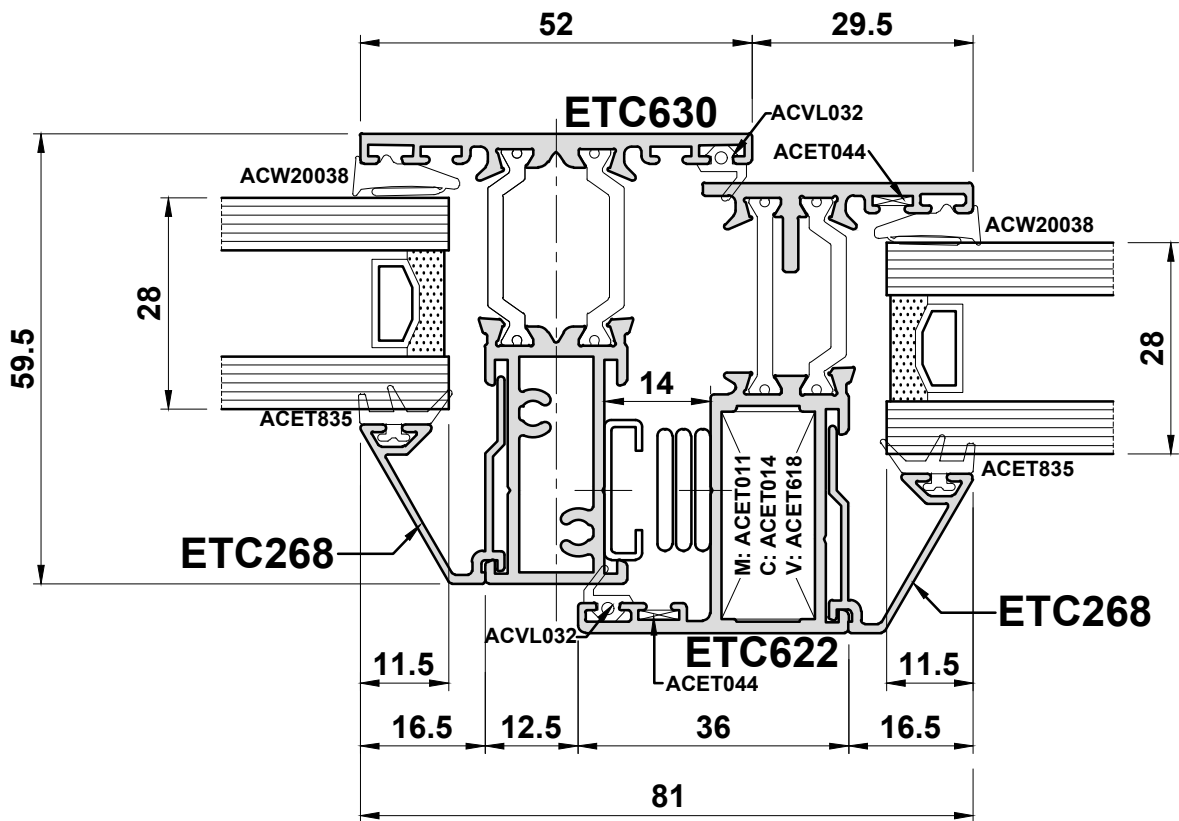
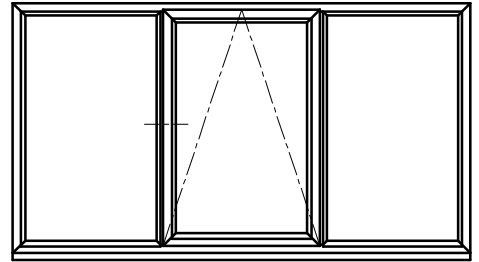
Do Not Scale From This Drawing

Detail 8C



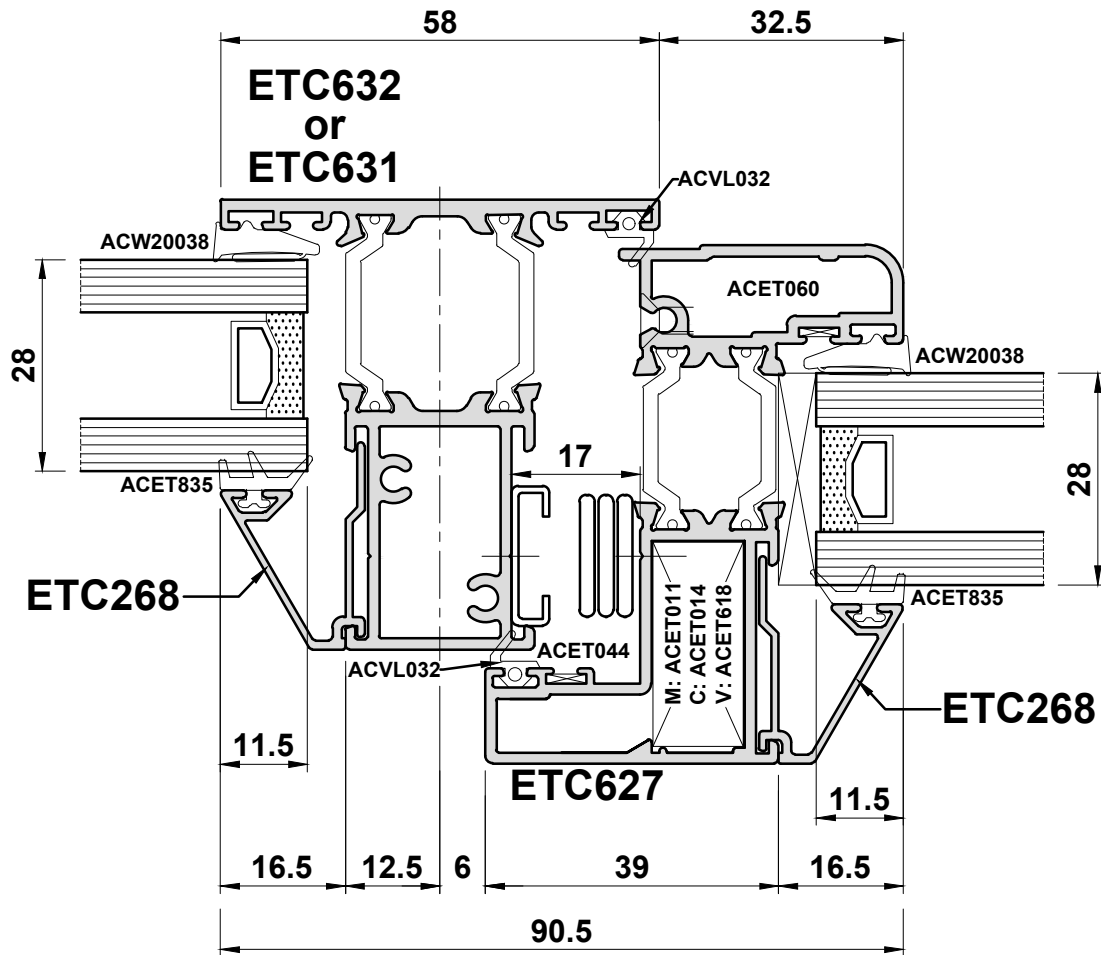
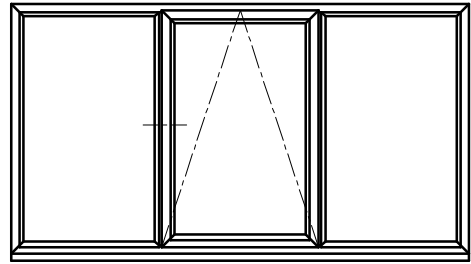
Do Not Scale From This Drawing

Detail 9A



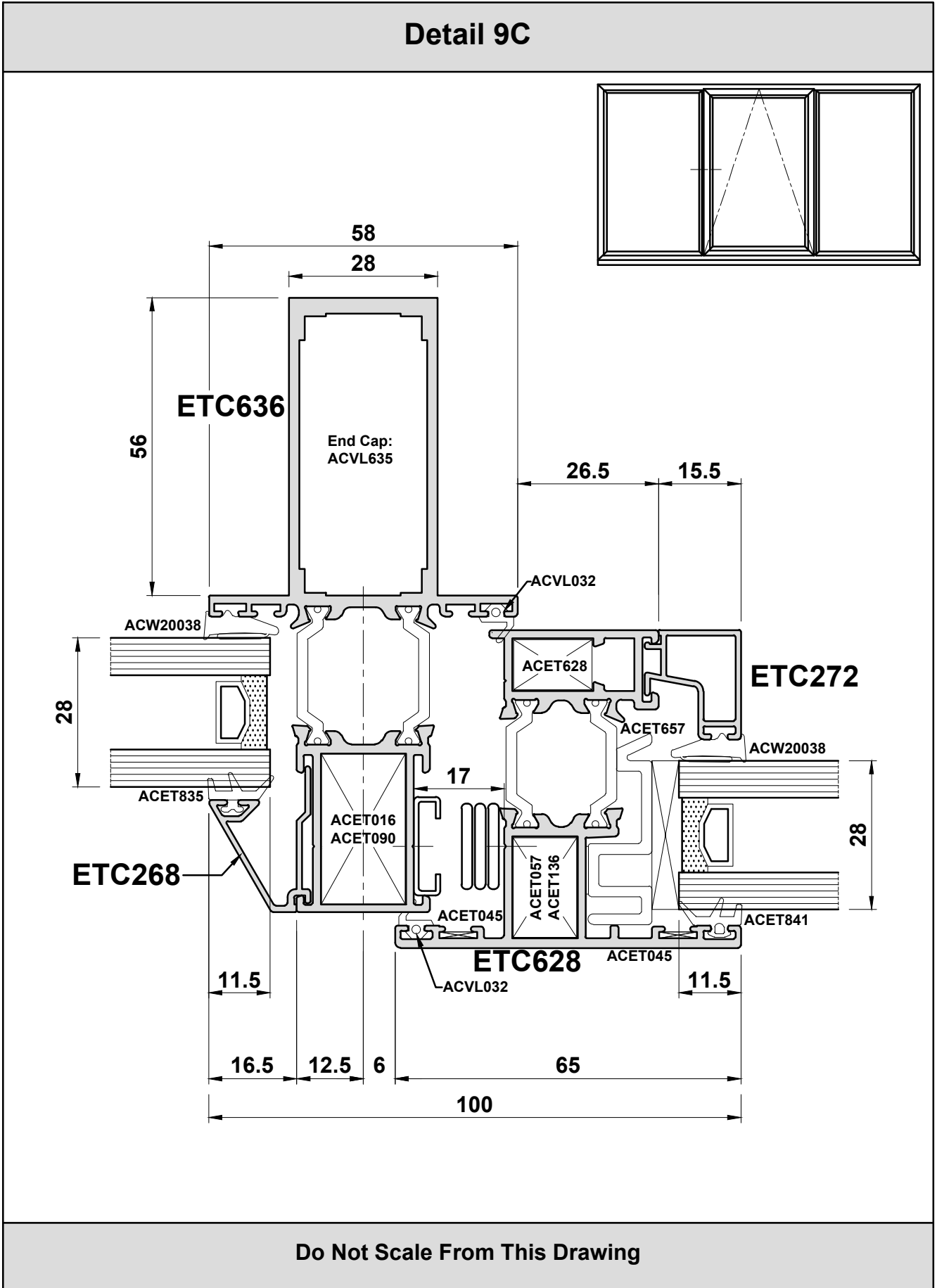
Do Not Scale From This Drawing

Detail 9B



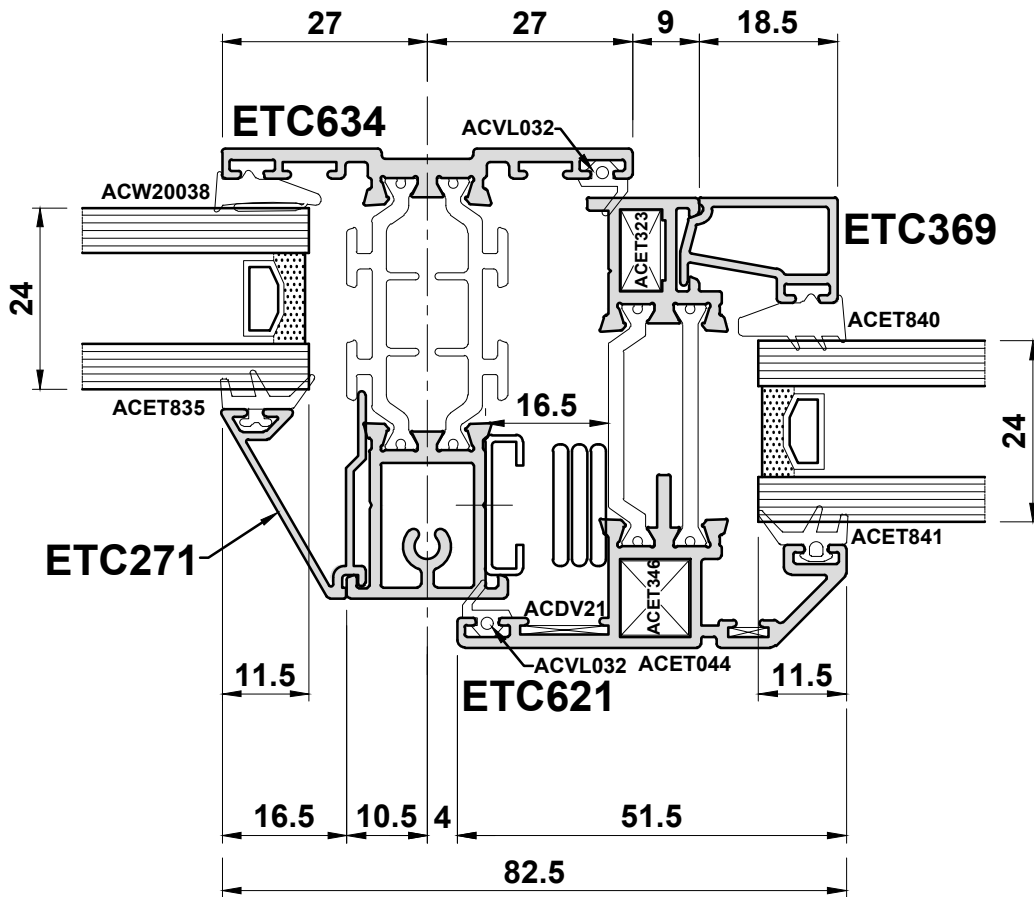
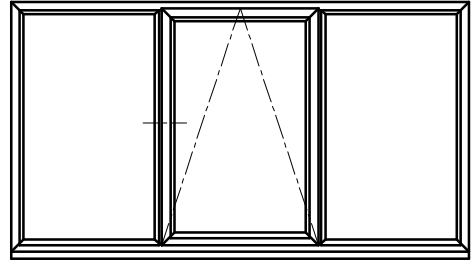
Do Not Scale From This Drawing

Detail 9C



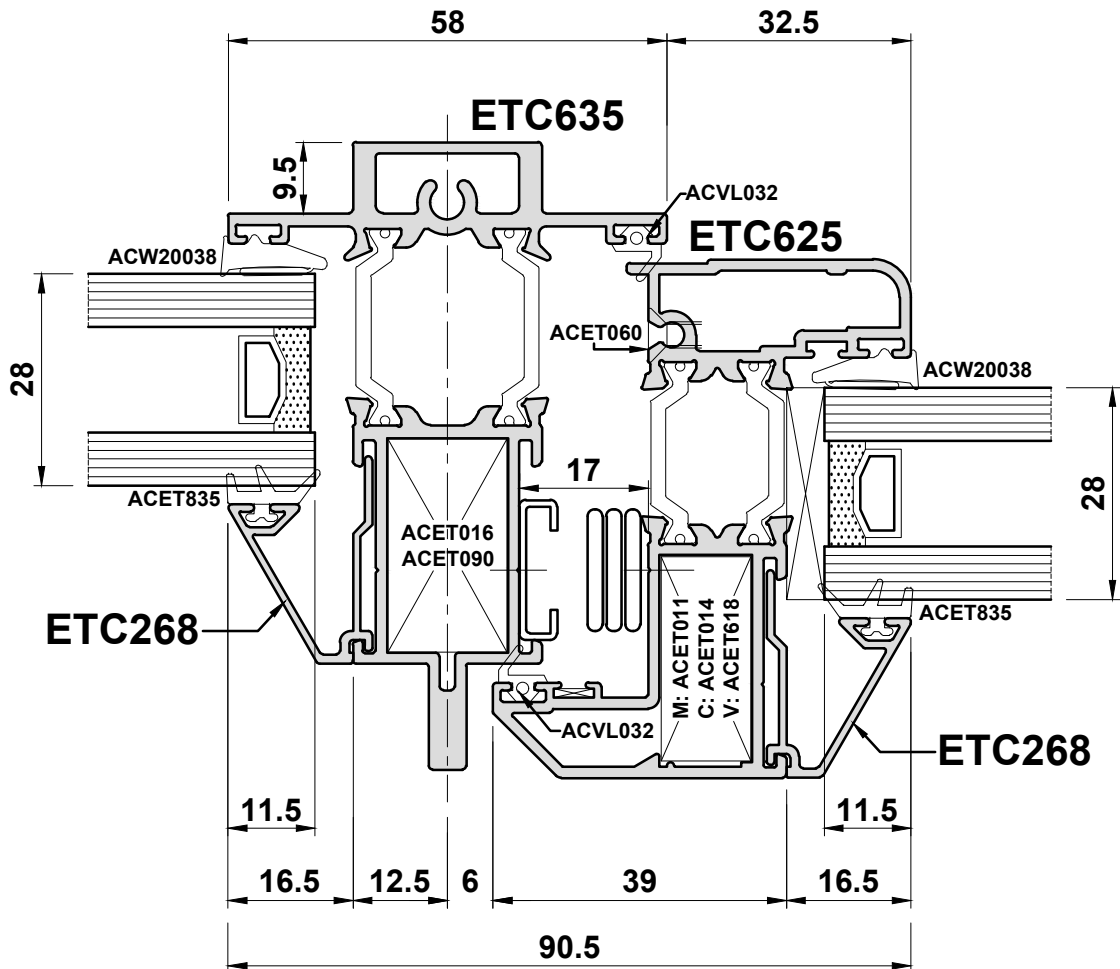
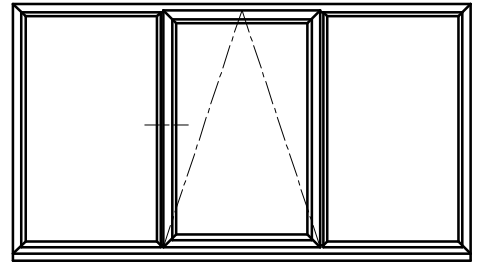
Do Not Scale From This Drawing

Detail 9D



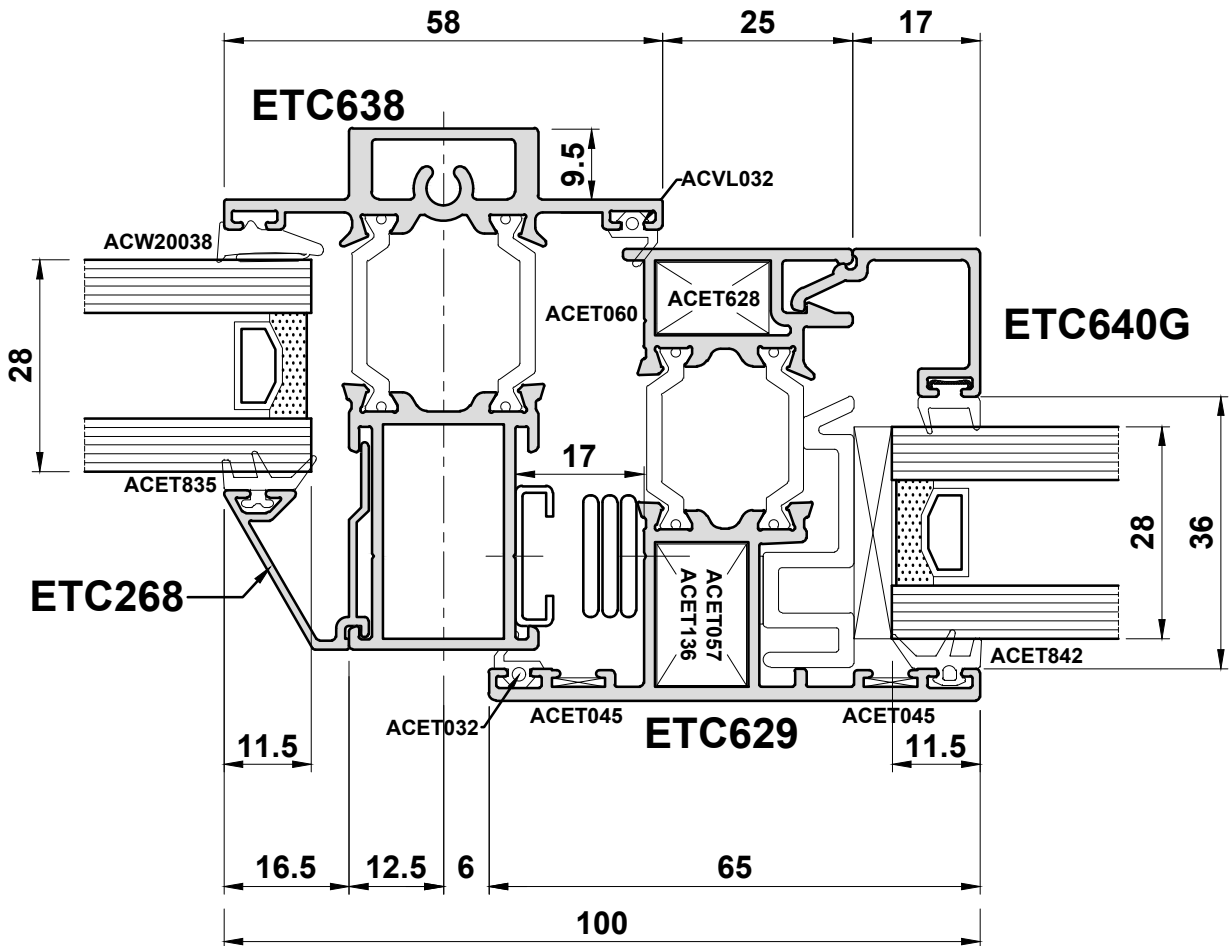
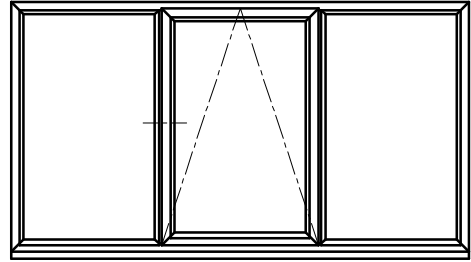
Do Not Scale From This Drawing

Detail 9E



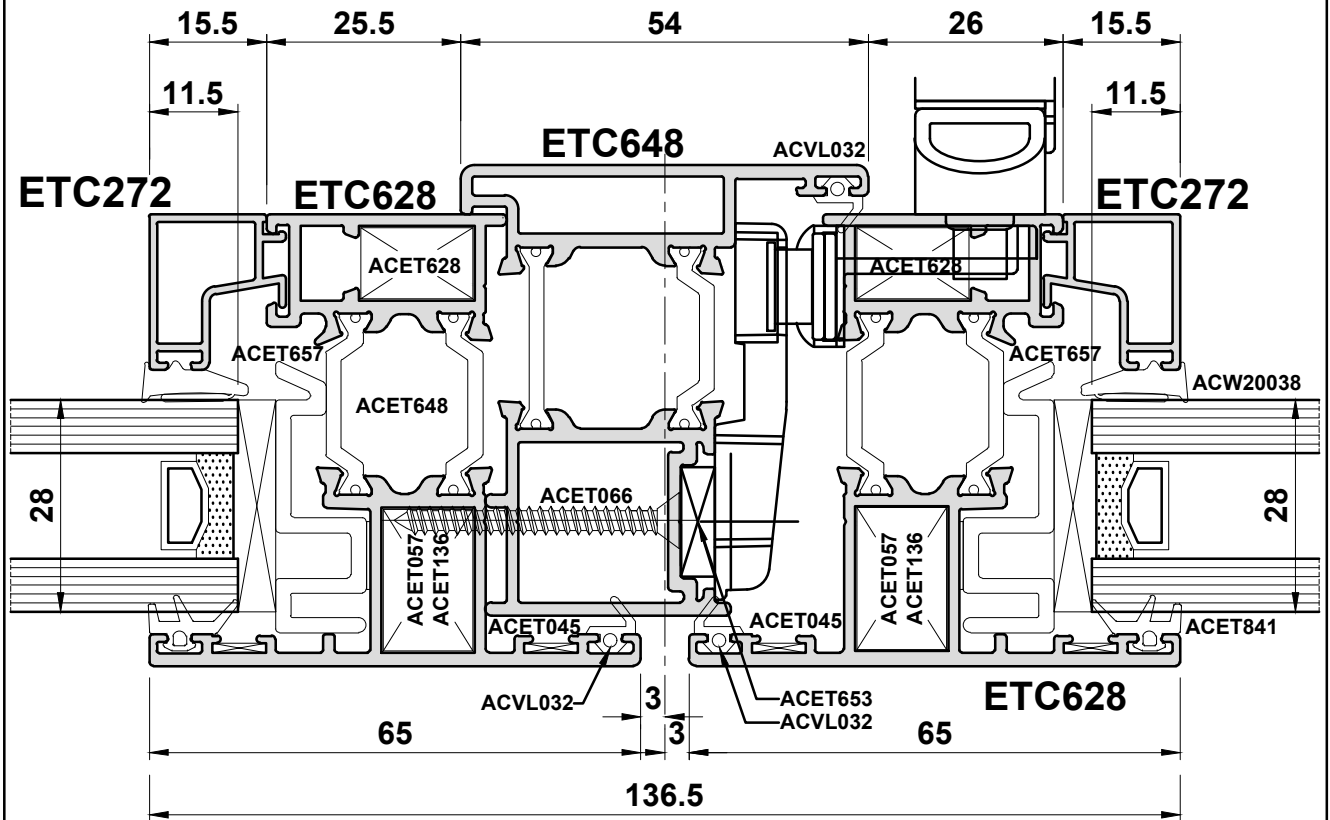
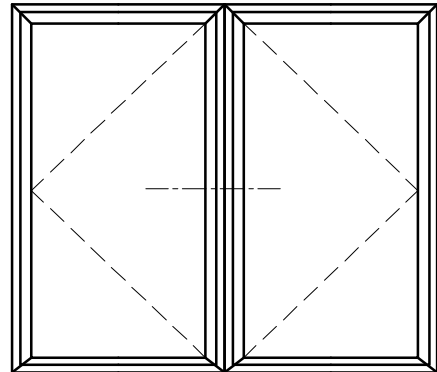
Do Not Scale From This Drawing

Detail 9F



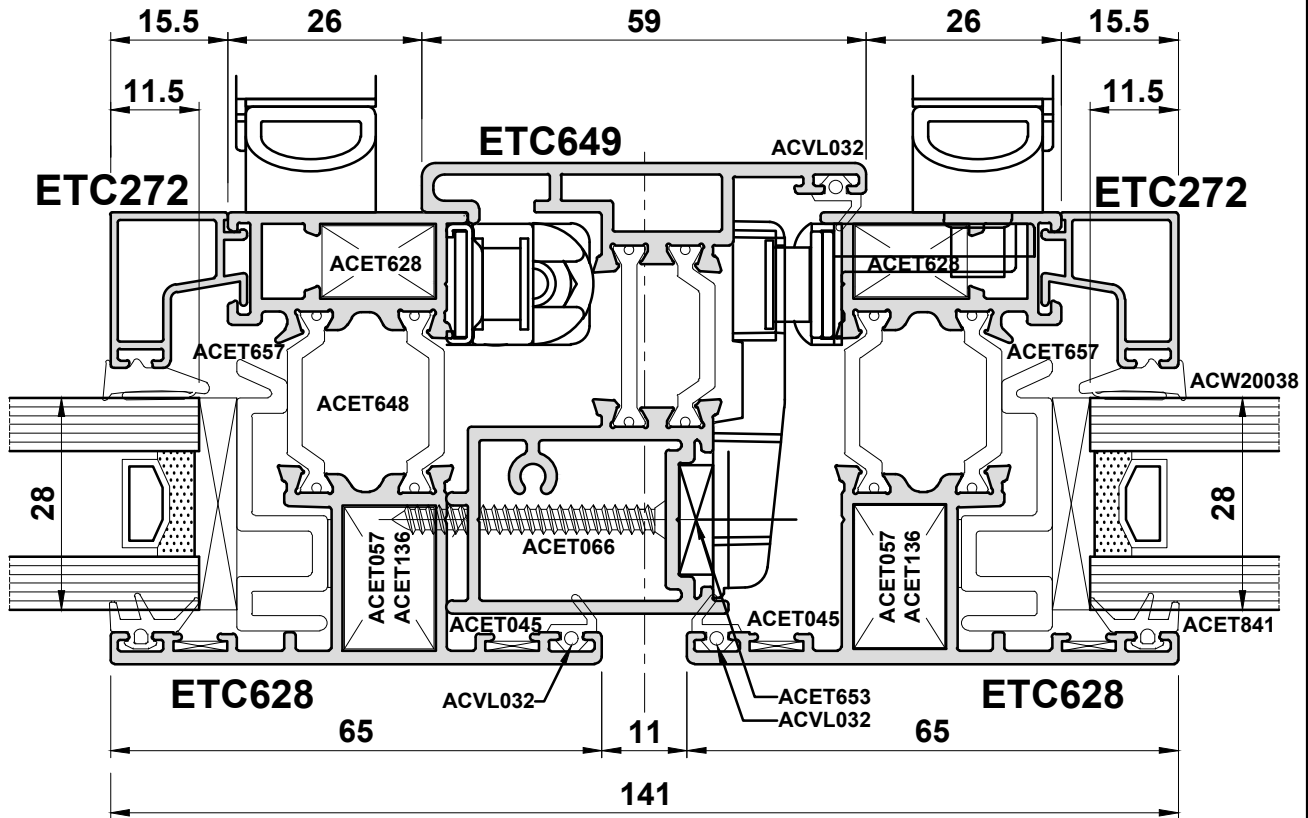
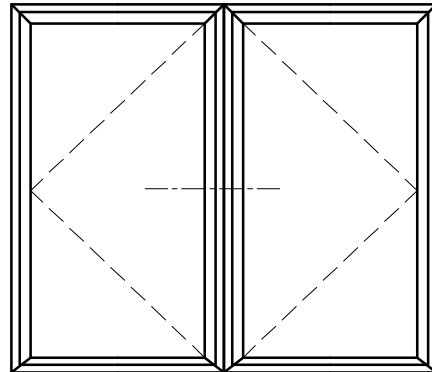
Do Not Scale From This Drawing

Detail 10A



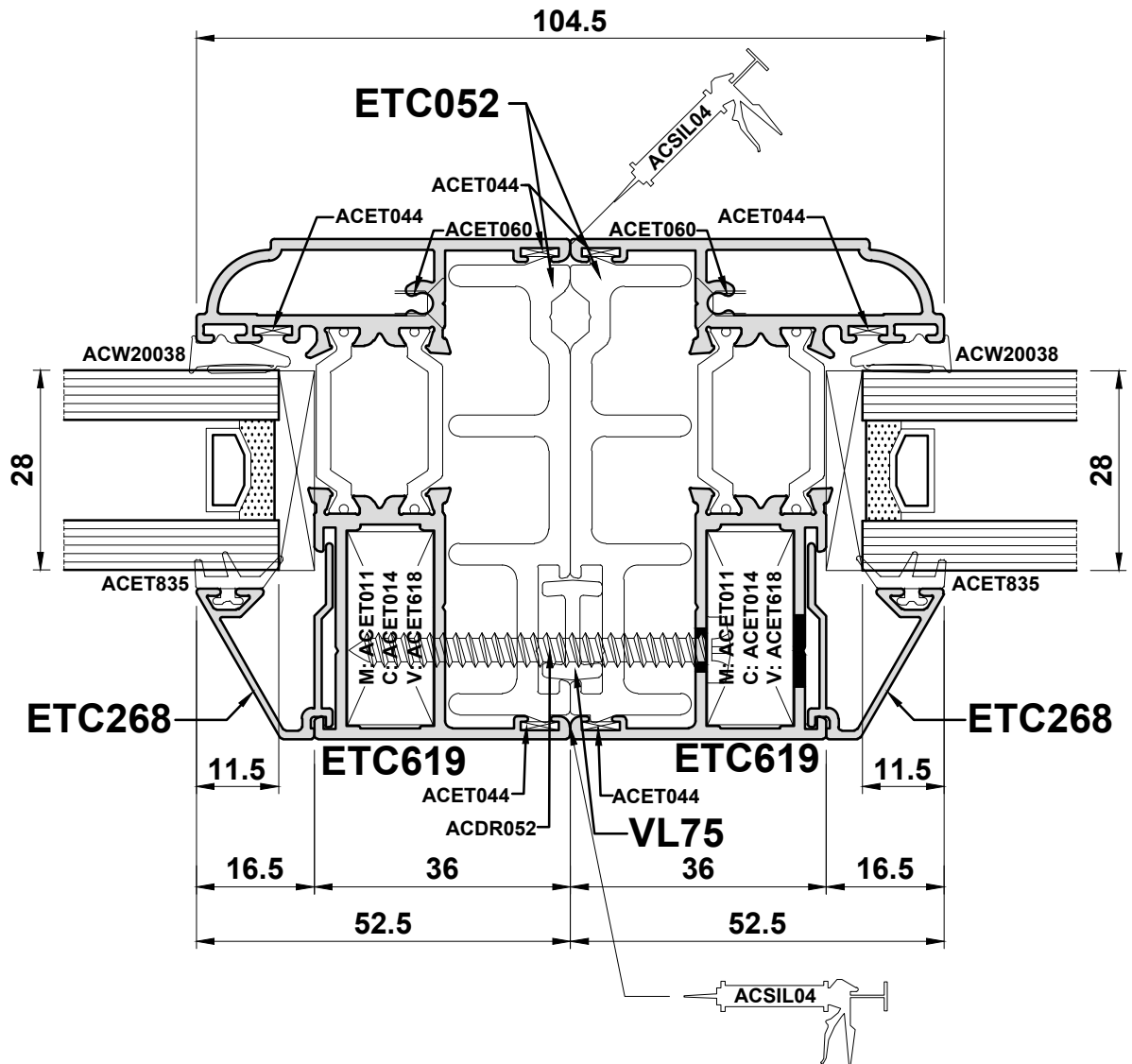
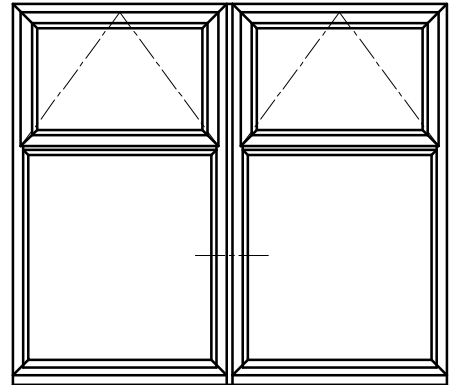
Do Not Scale From This Drawing

Detail 10B



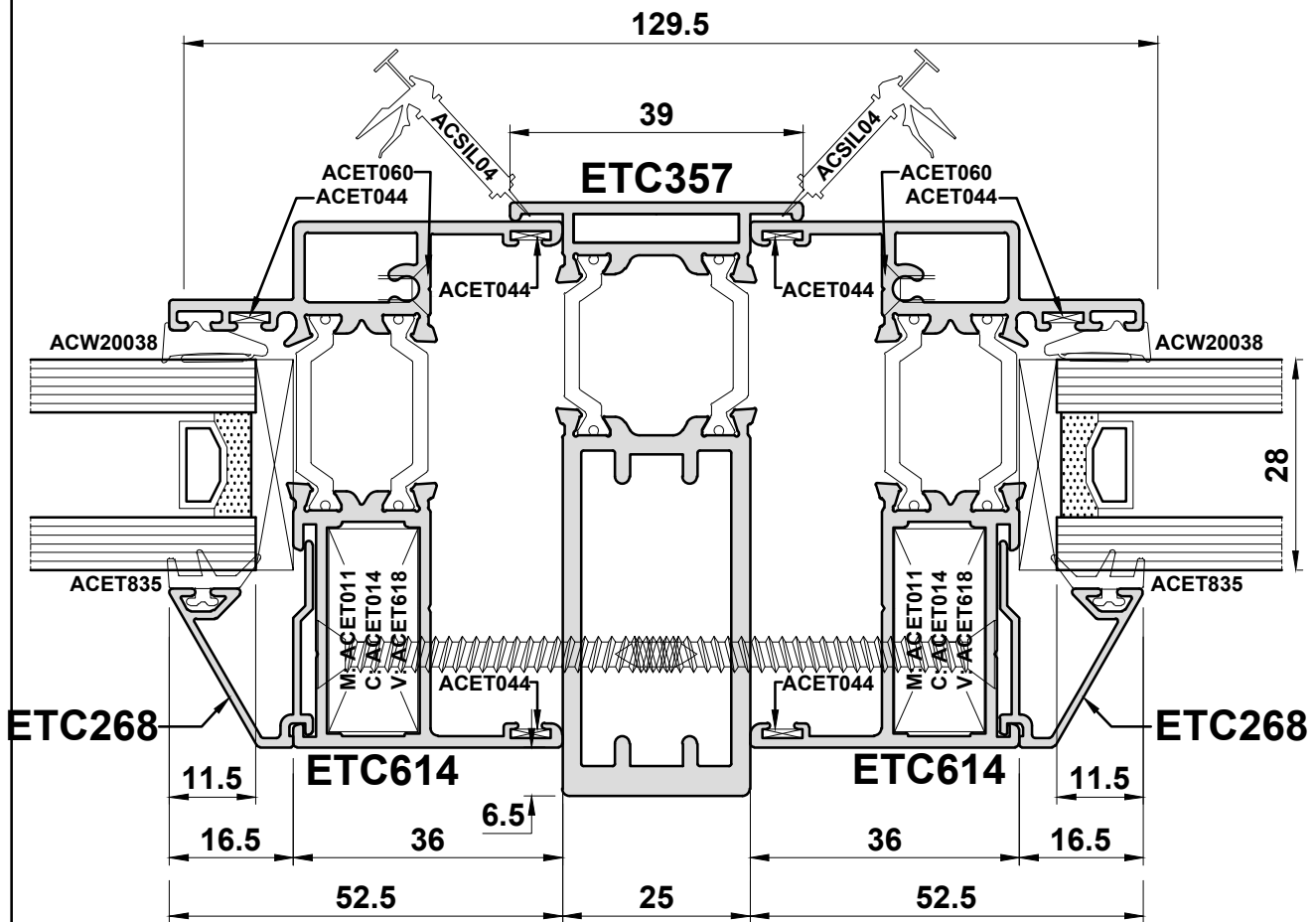
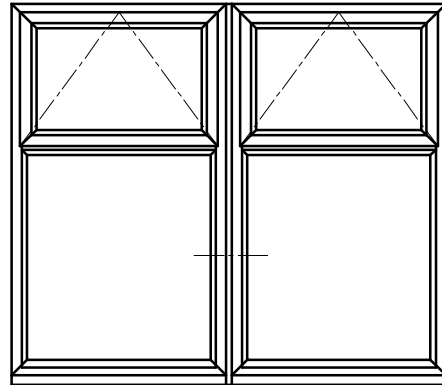
Do Not Scale From This Drawing

Detail 11A



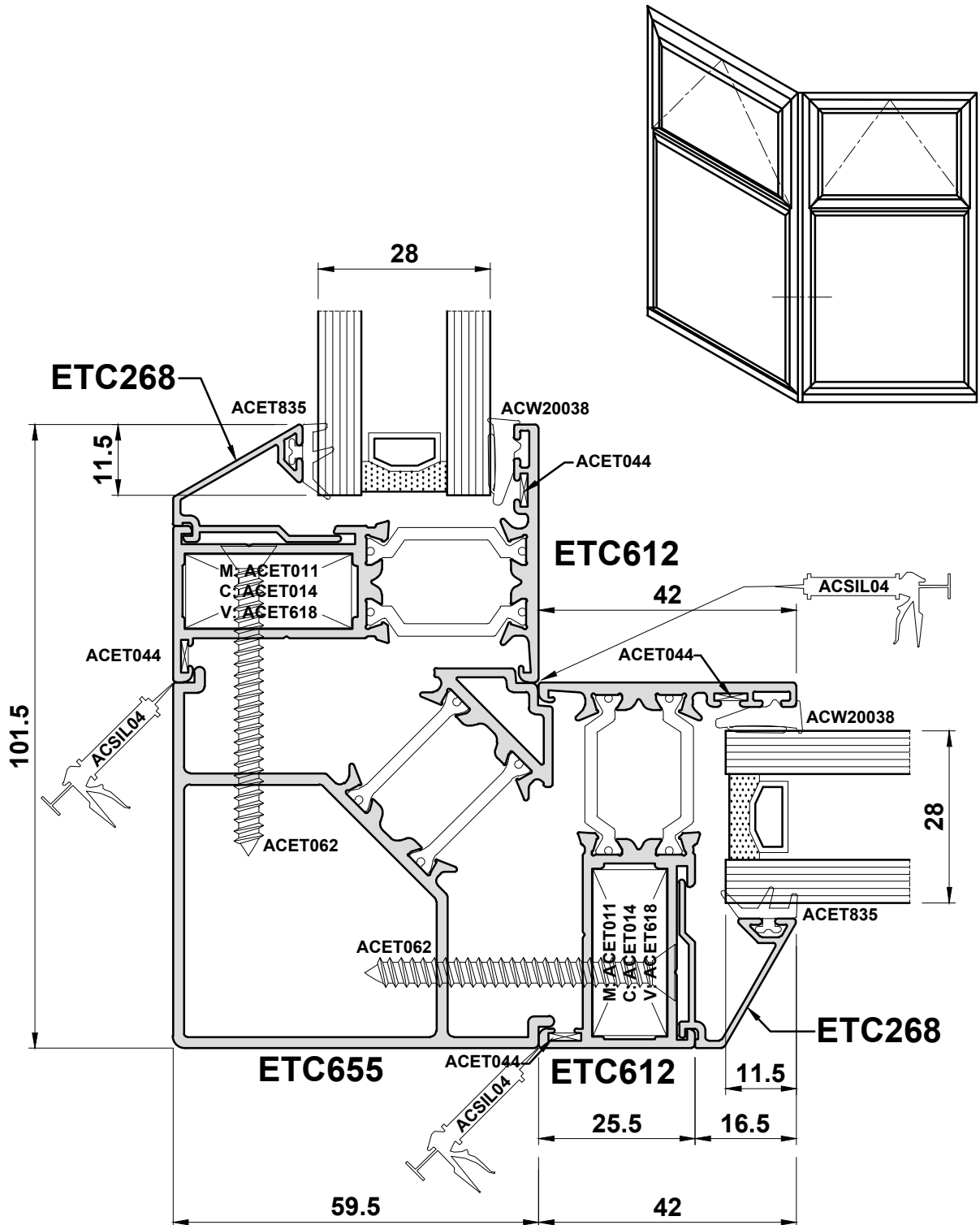
Do Not Scale From This Drawing

Detail 11B



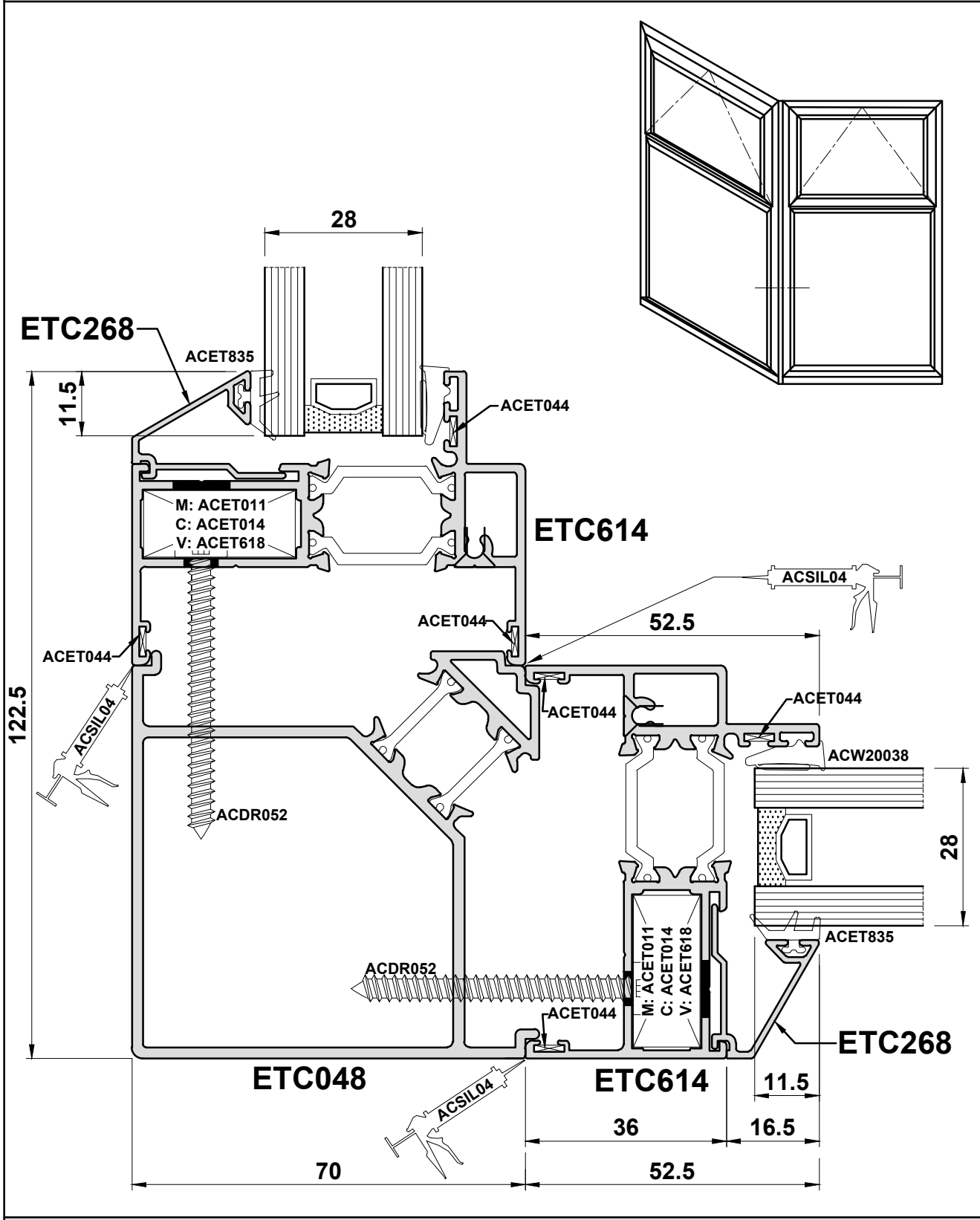
Do Not Scale From This Drawing

Detail 11C



Do Not Scale From This Drawing

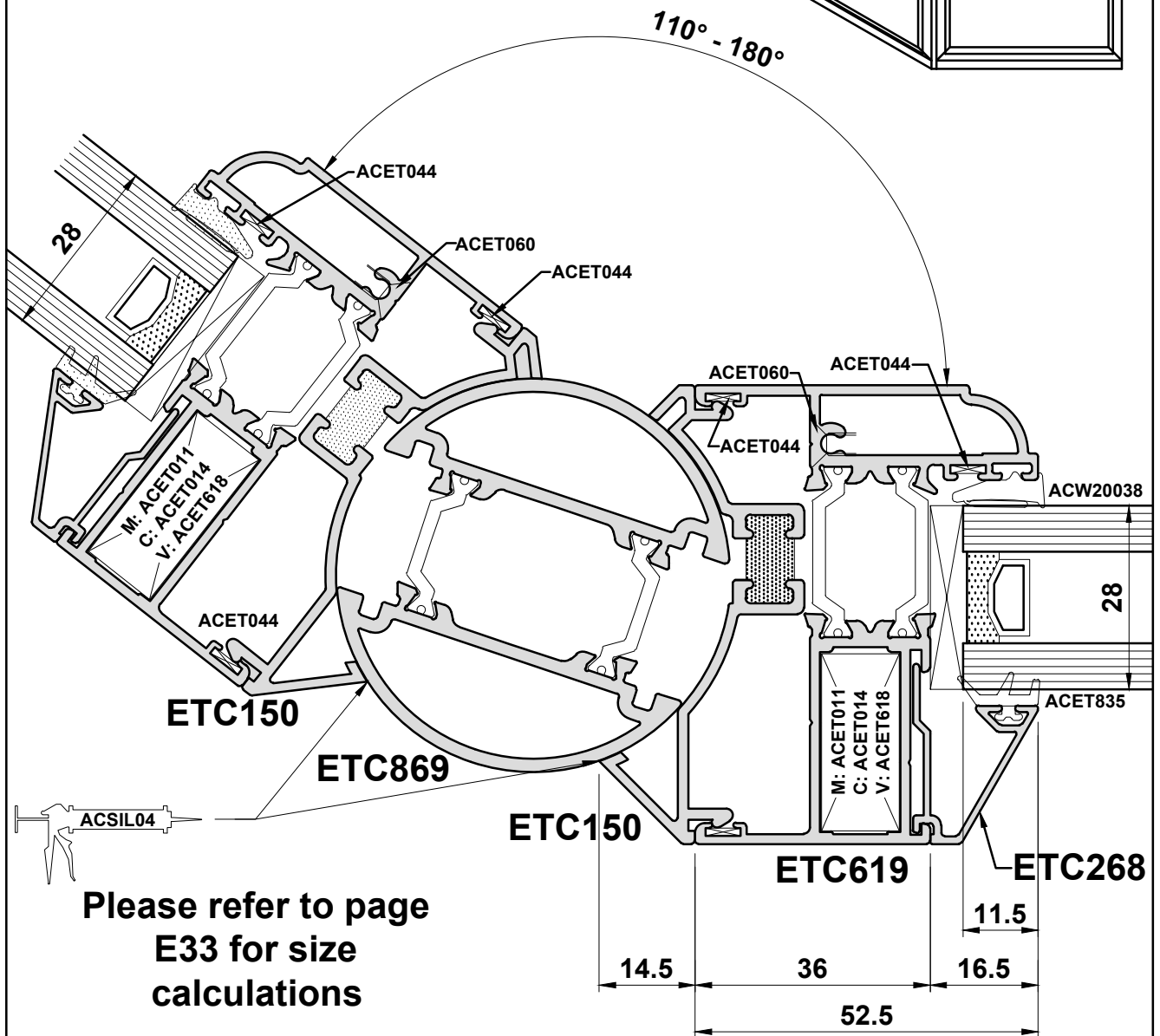
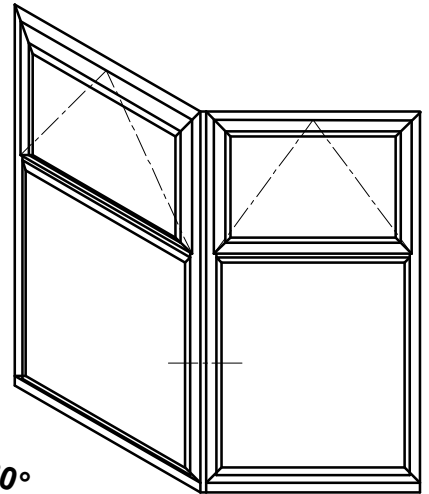
Detail 11D



Do Not Scale From This Drawing

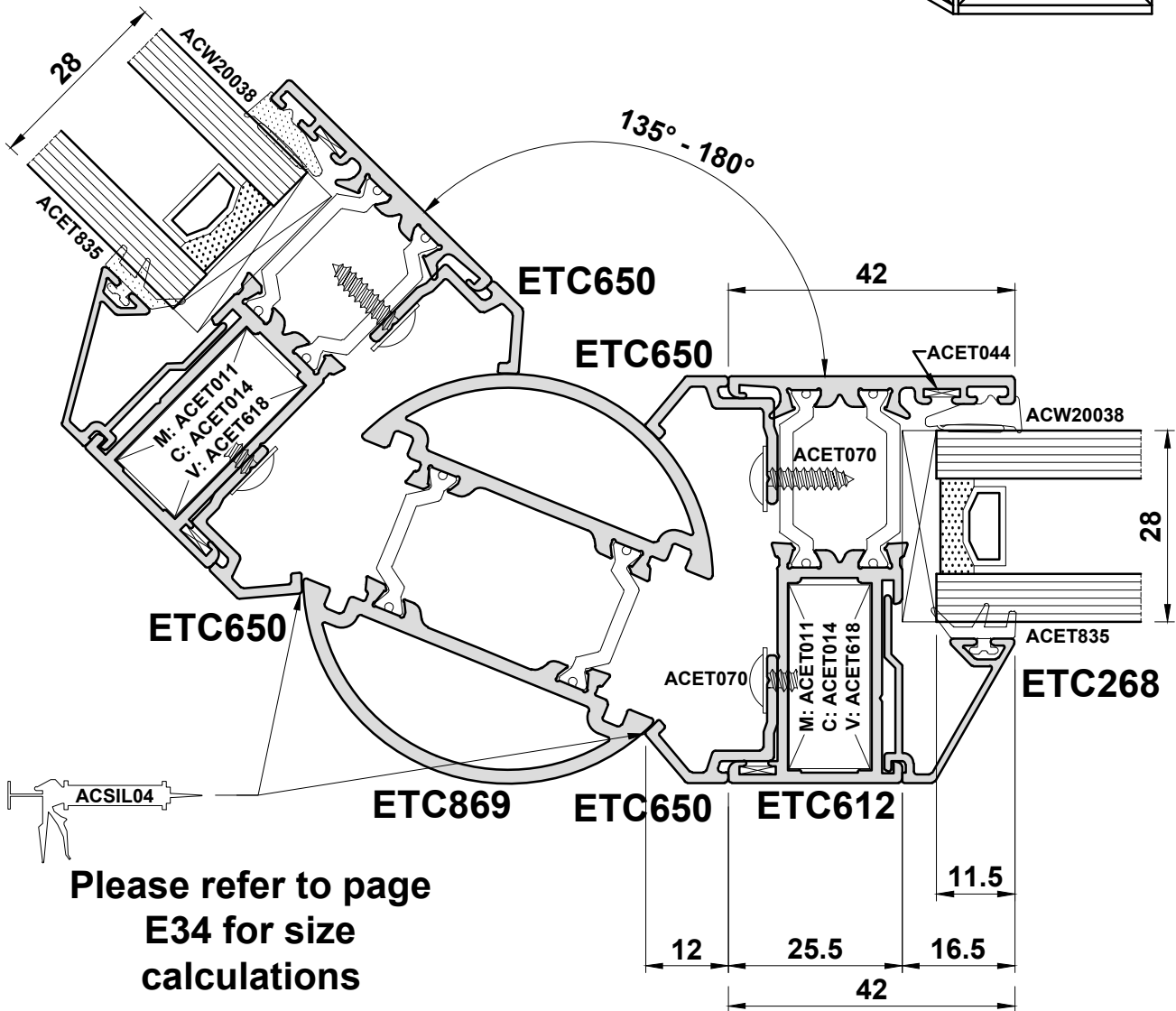
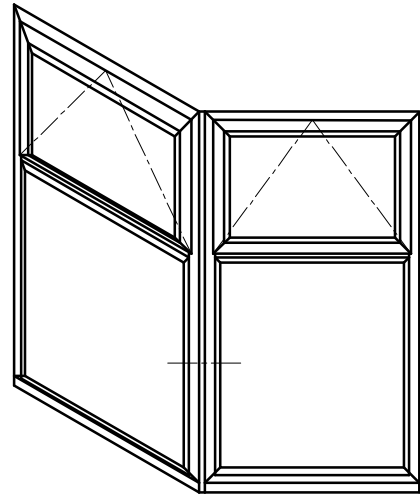
Detail 11E

Dual Colour is not available with ETC150



Do Not Scale From This Drawing

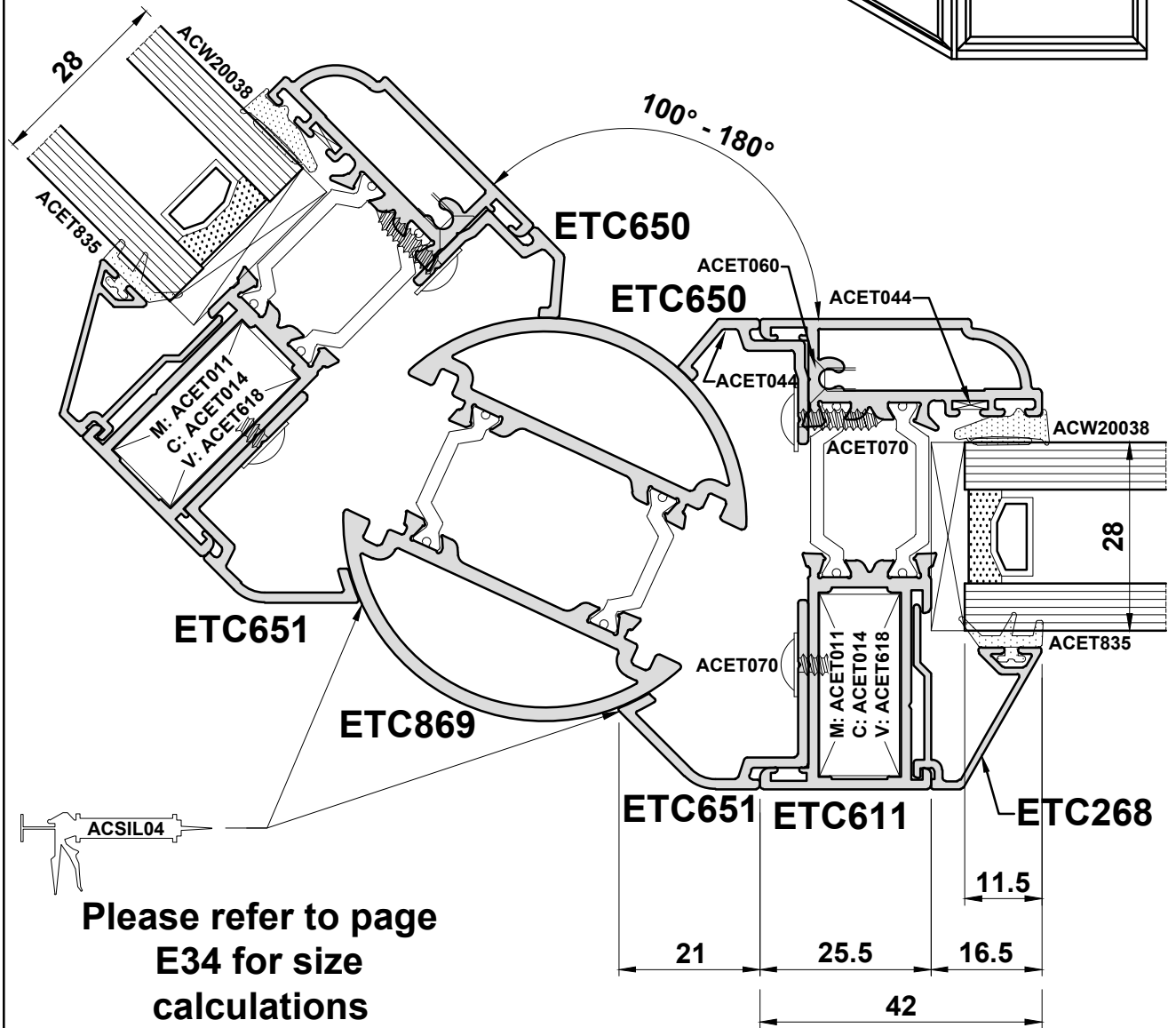
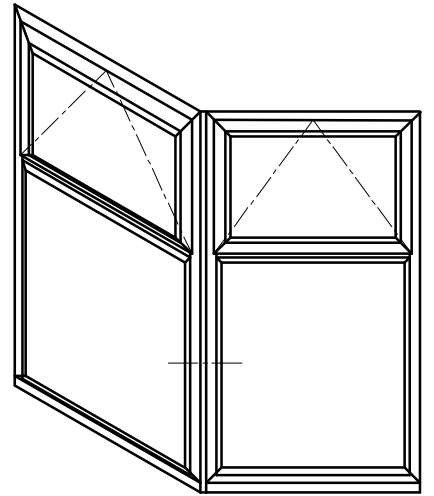
Detail 11F



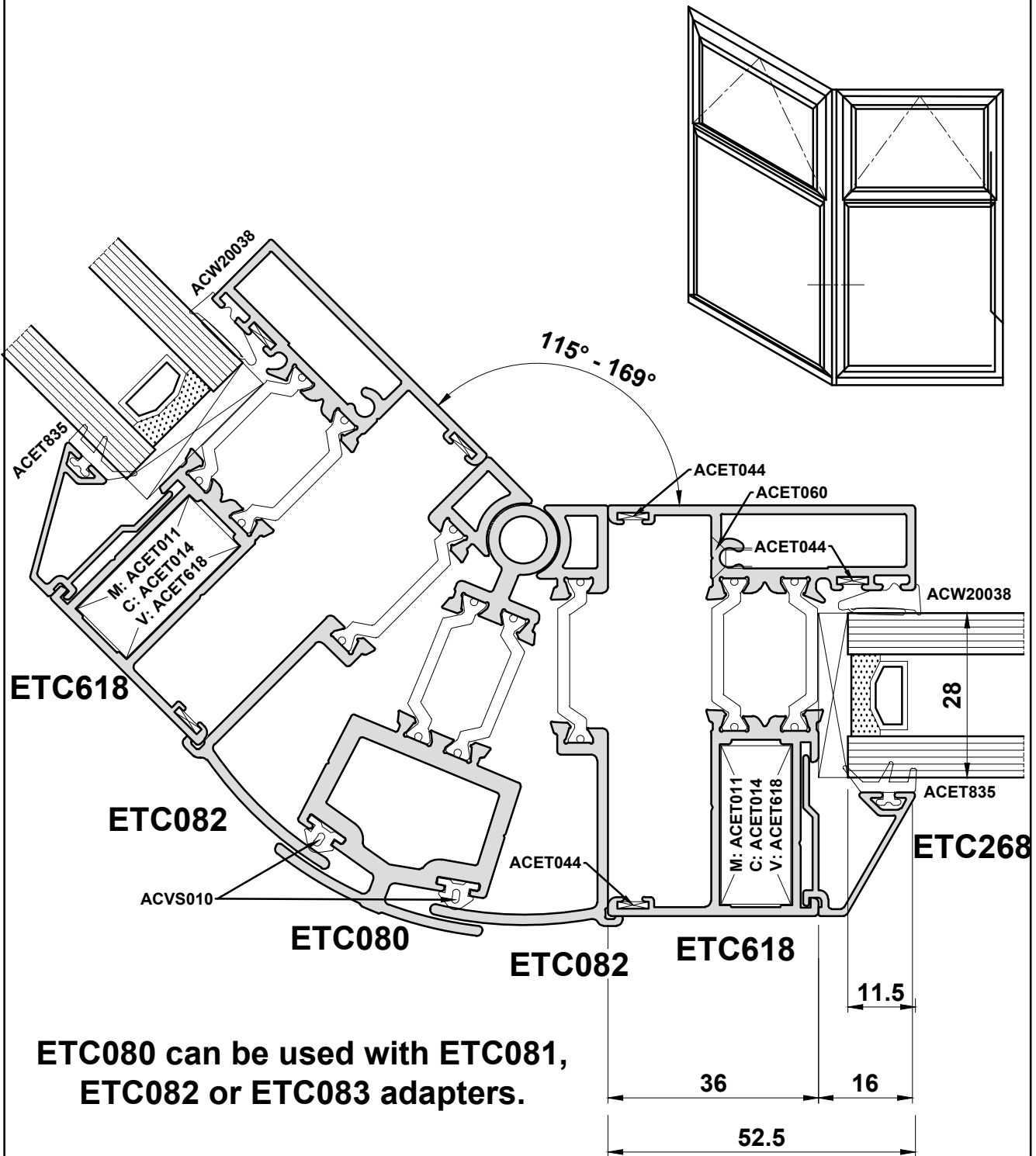
Please refer to page
E34 for size
calculations

Do Not Scale From This Drawing

Detail 11G



Detail 11H

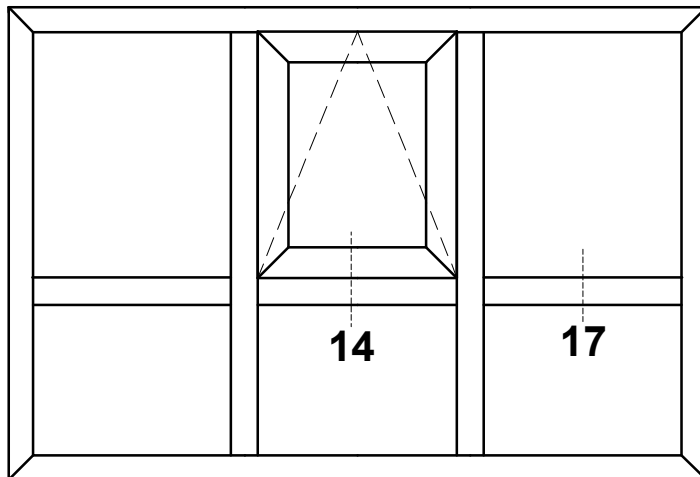
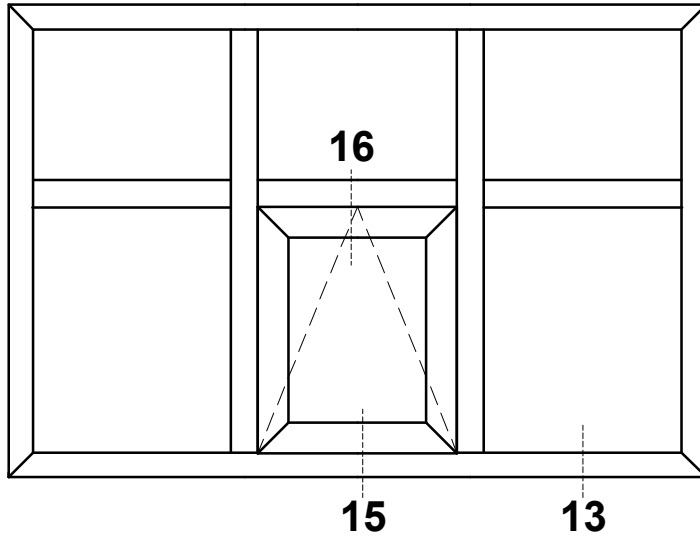


**ETC080 can be used with ETC081,
ETC082 or ETC083 adapters.**

**Please refer to page E35 for size
calculations**

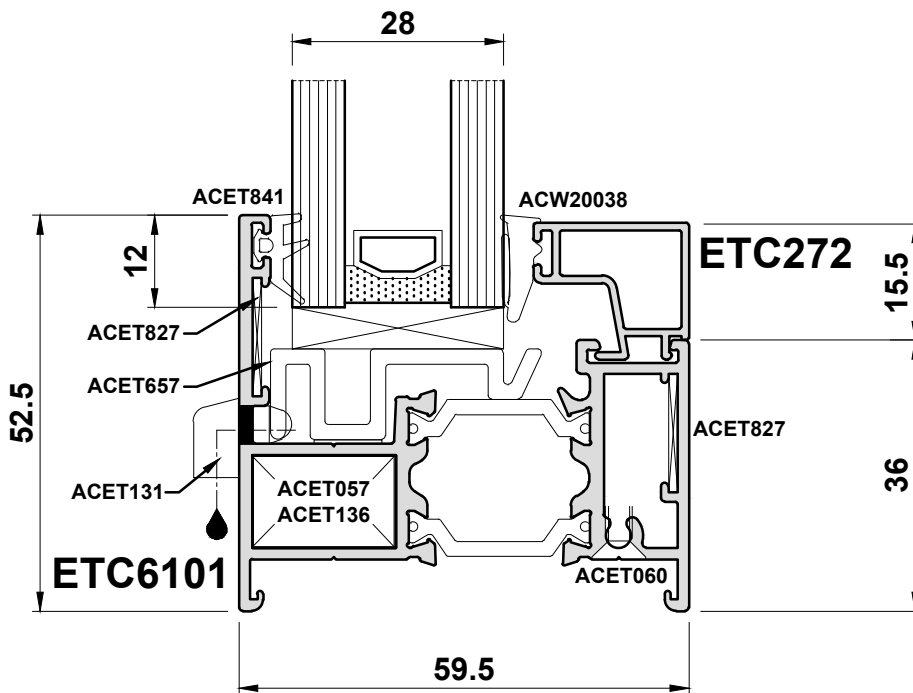
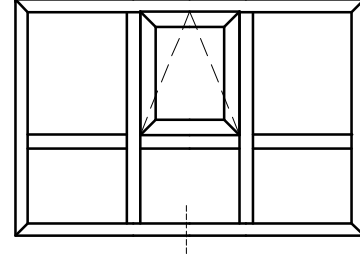
Do Not Scale From This Drawing

Scale Elevations - Internally Glazed



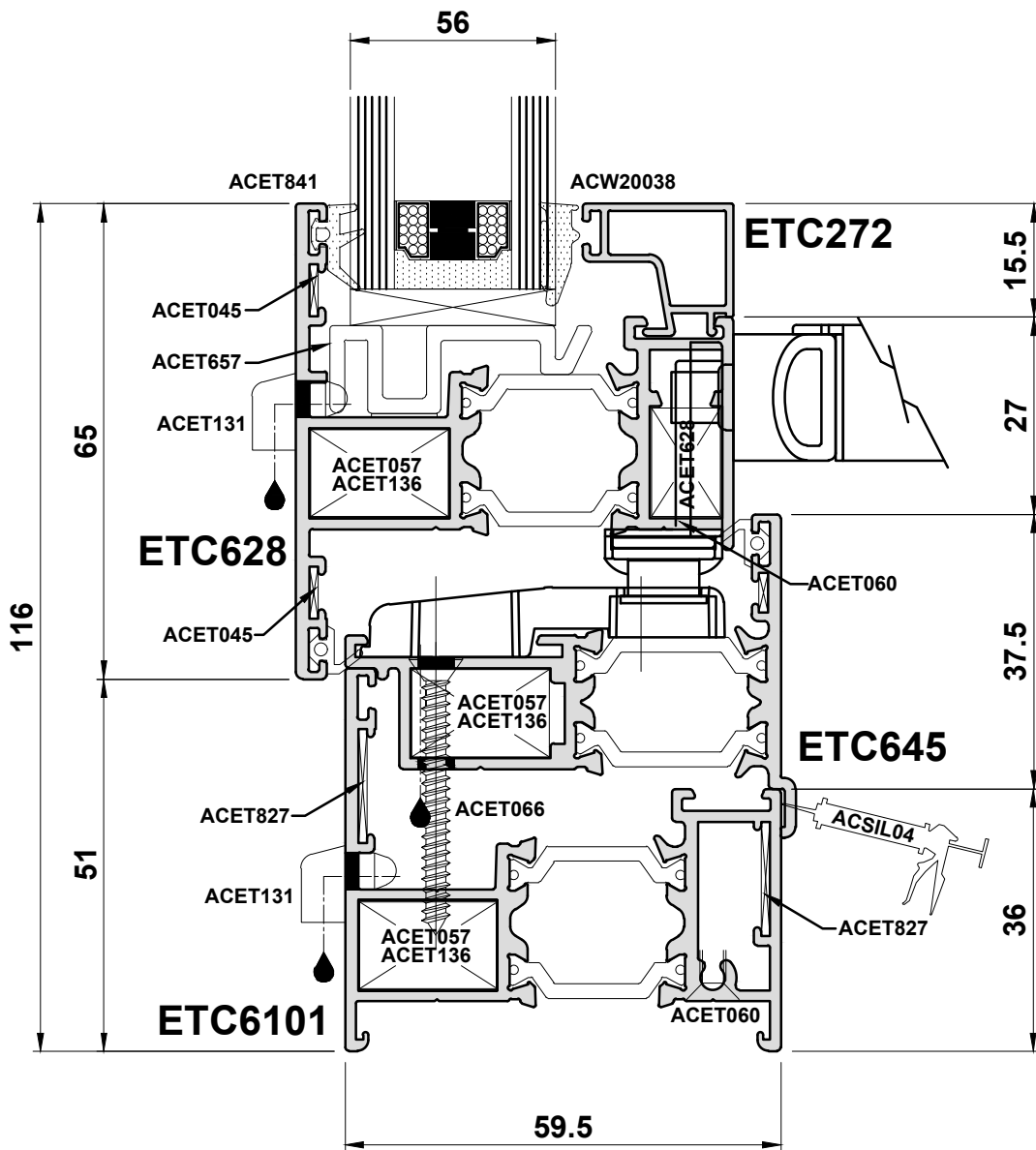
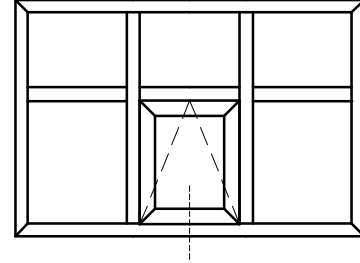
Do Not Scale From This Drawing

Detail 13



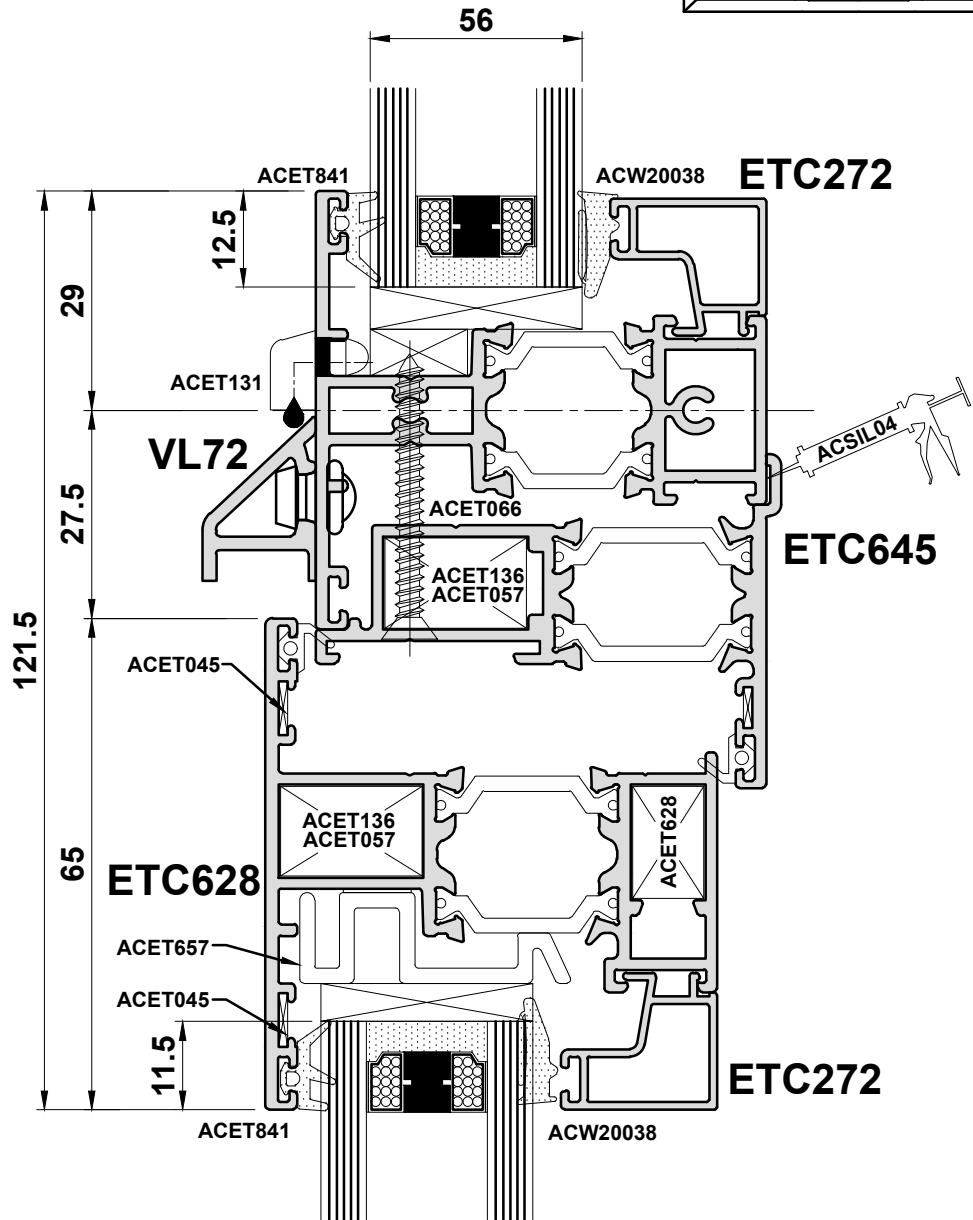
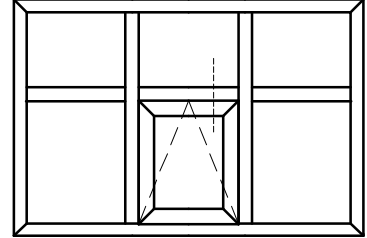
Do Not Scale From This Drawing

Detail 15

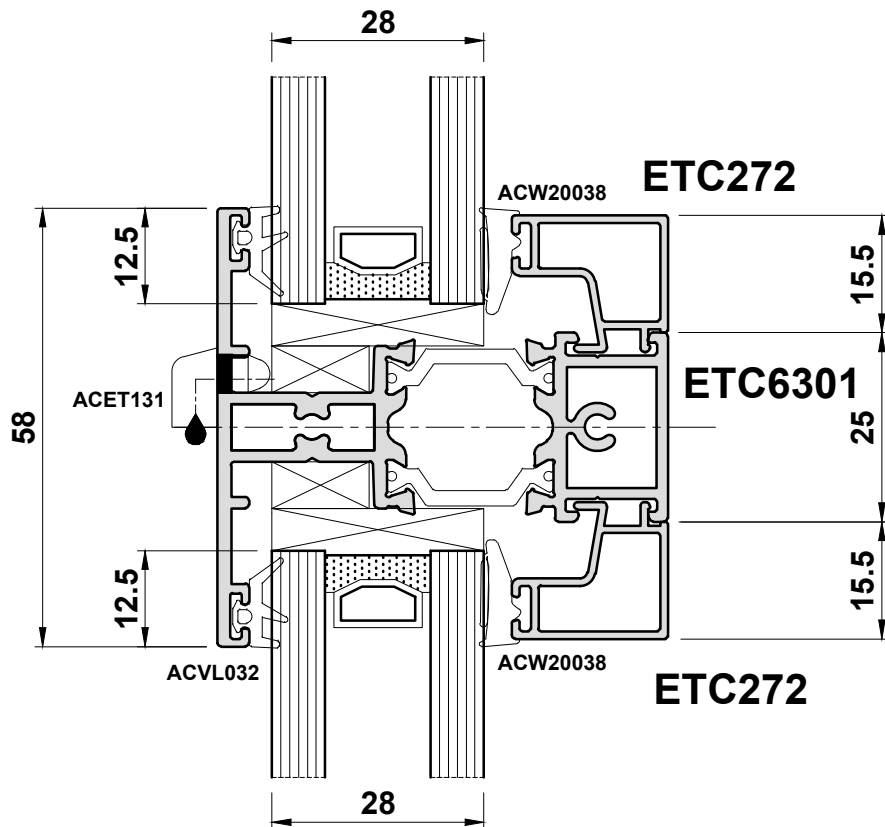
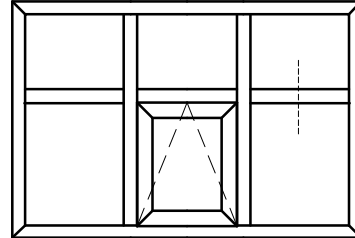


Do Not Scale From This Drawing

Detail 16



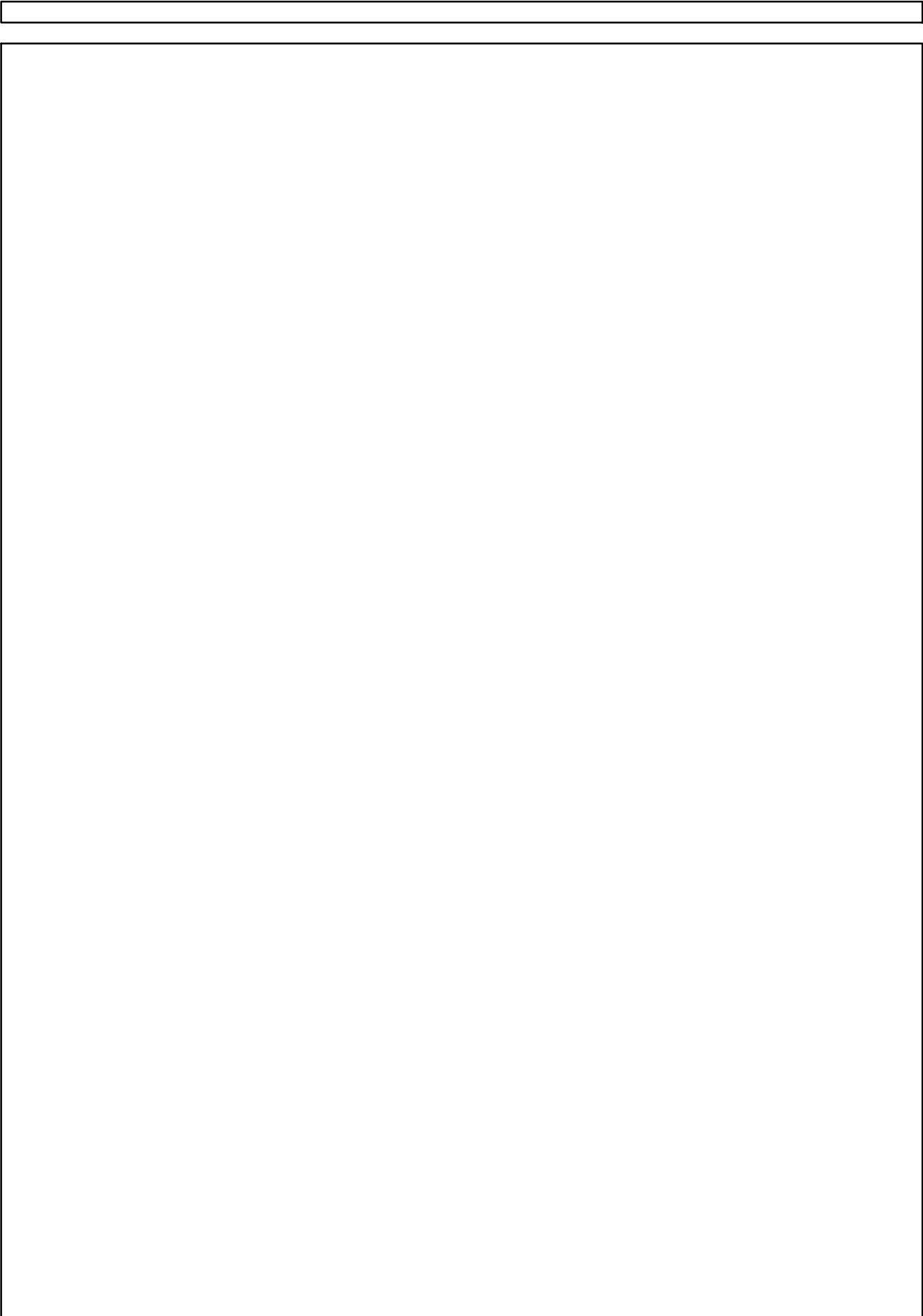
Detail 17



Section D

Statics

**For Wind Loading Limitations,
Please Contact
The Technical Department.**



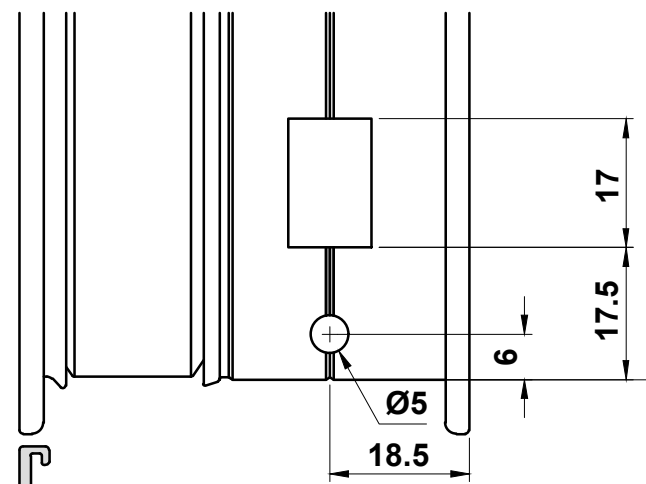
Section E

Construction Drawings

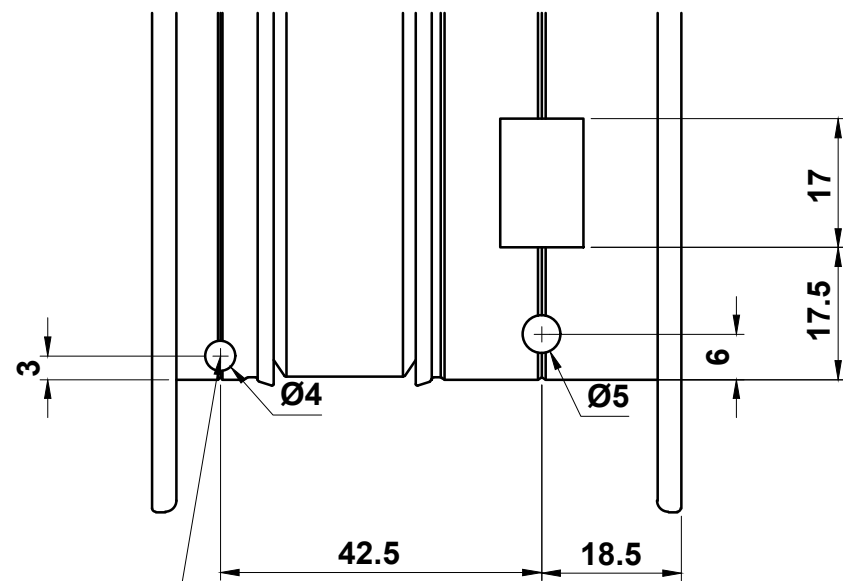
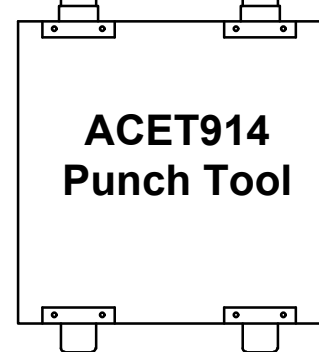
Corner Jointing	Page E03-E07
Drainage	Page E08-E09
Variable Angle Cill Detail	Page E10
Transom/Mullion Fixings	Page E11-E21
UN3000 Horizontal Coupler Detail	Page E22
Hinges - System Parameters	Page E23-E27
Locking Hardware - System Parameters	Page E28-E31
French Casement Detail	Page E32-E33
Bead & Glazing	Page E34-E38
Bay Pole Details	Page E39-E42
Internally Glazed Example	Page E43
Fixing Strap Guide	Page E44

Section E

Corner Assembly - Mechanical Cleats



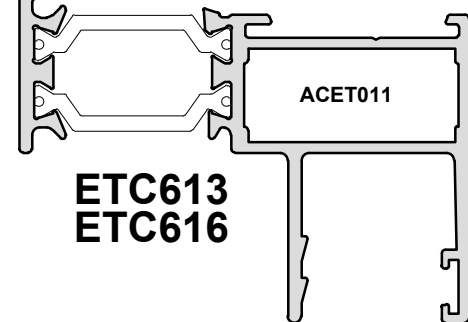
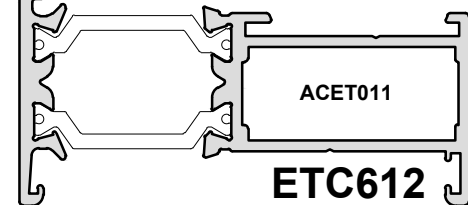
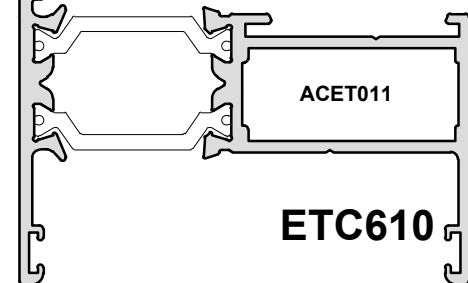
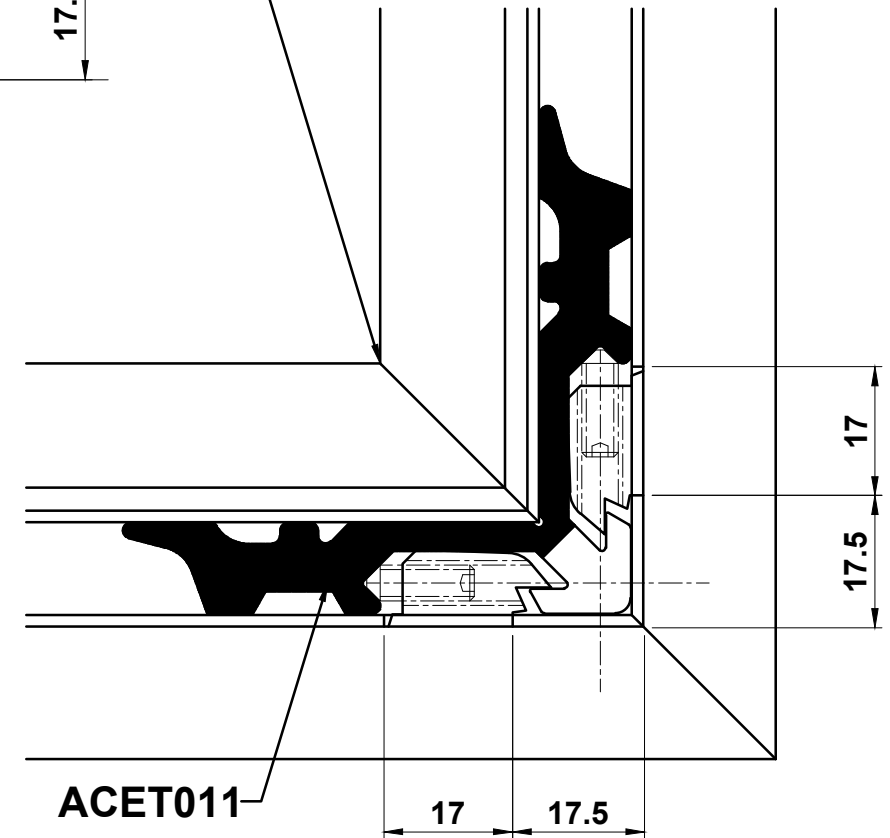
**ETC631, ETC635,
ETC638**



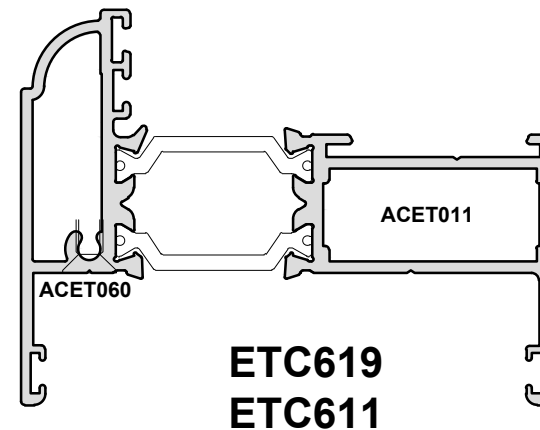
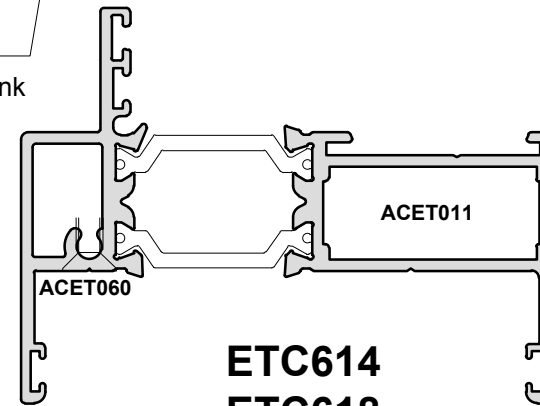
**ETC610, ETC611
ETC612, ETC613
ETC614, ETC616
ETC618, ETC619**

Stepped drill ACET907 can be used to drill and countersink simultaneously

Coat Cut Face of Profile with ACSIL04 Prior to Mechanically Joining



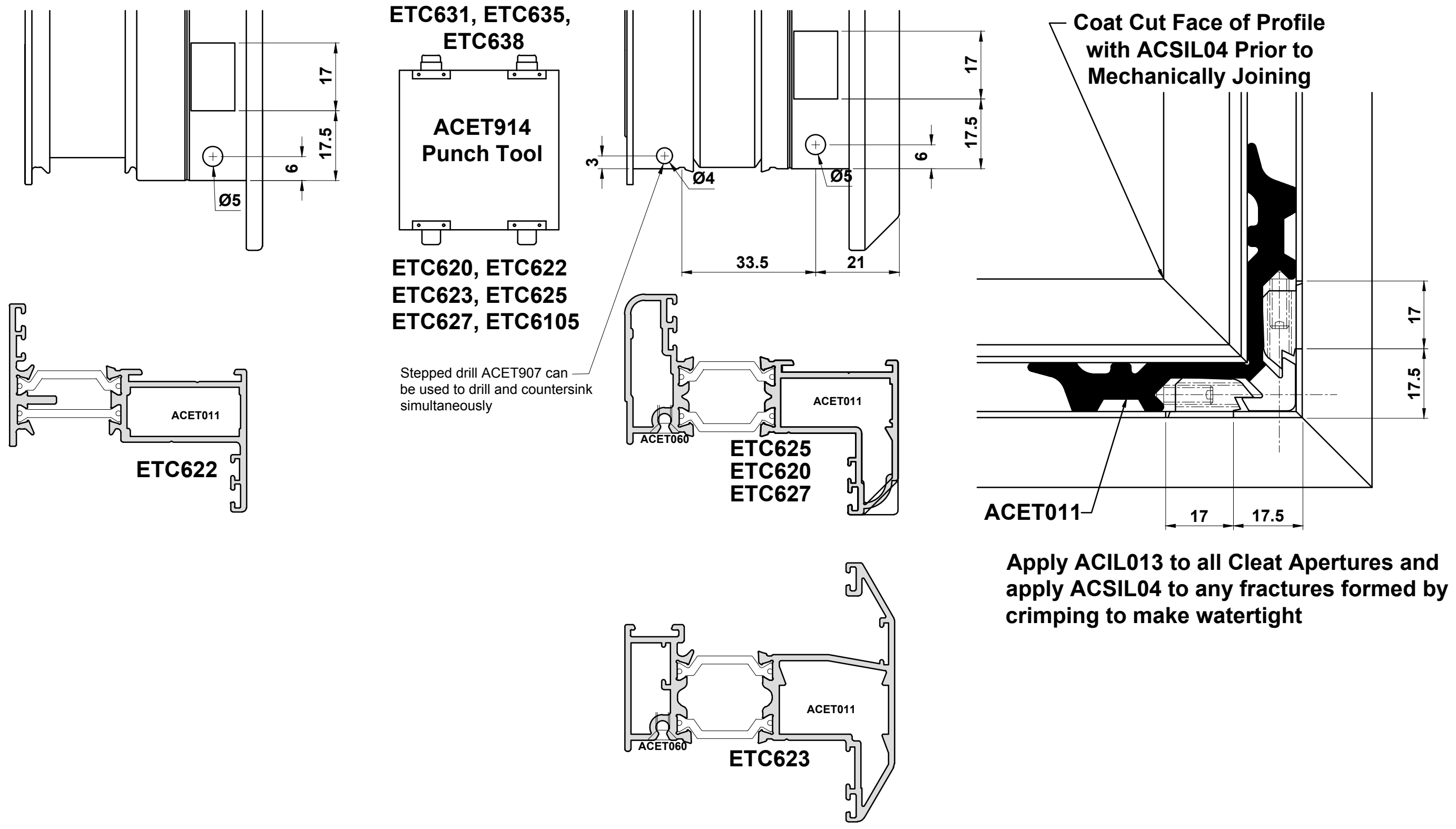
- Notes**
1. Degrease mitre sections
 2. Cover mitred faces with ACSIL04
 3. Apply ACSIL013 to cleat chamber
 4. Apply ACSIL04 to any fractures formed by crimping to make watertight



Apply ACIL013 to all Cleat Apertures and apply ACSIL04 to any fractures formed by crimping to make watertight

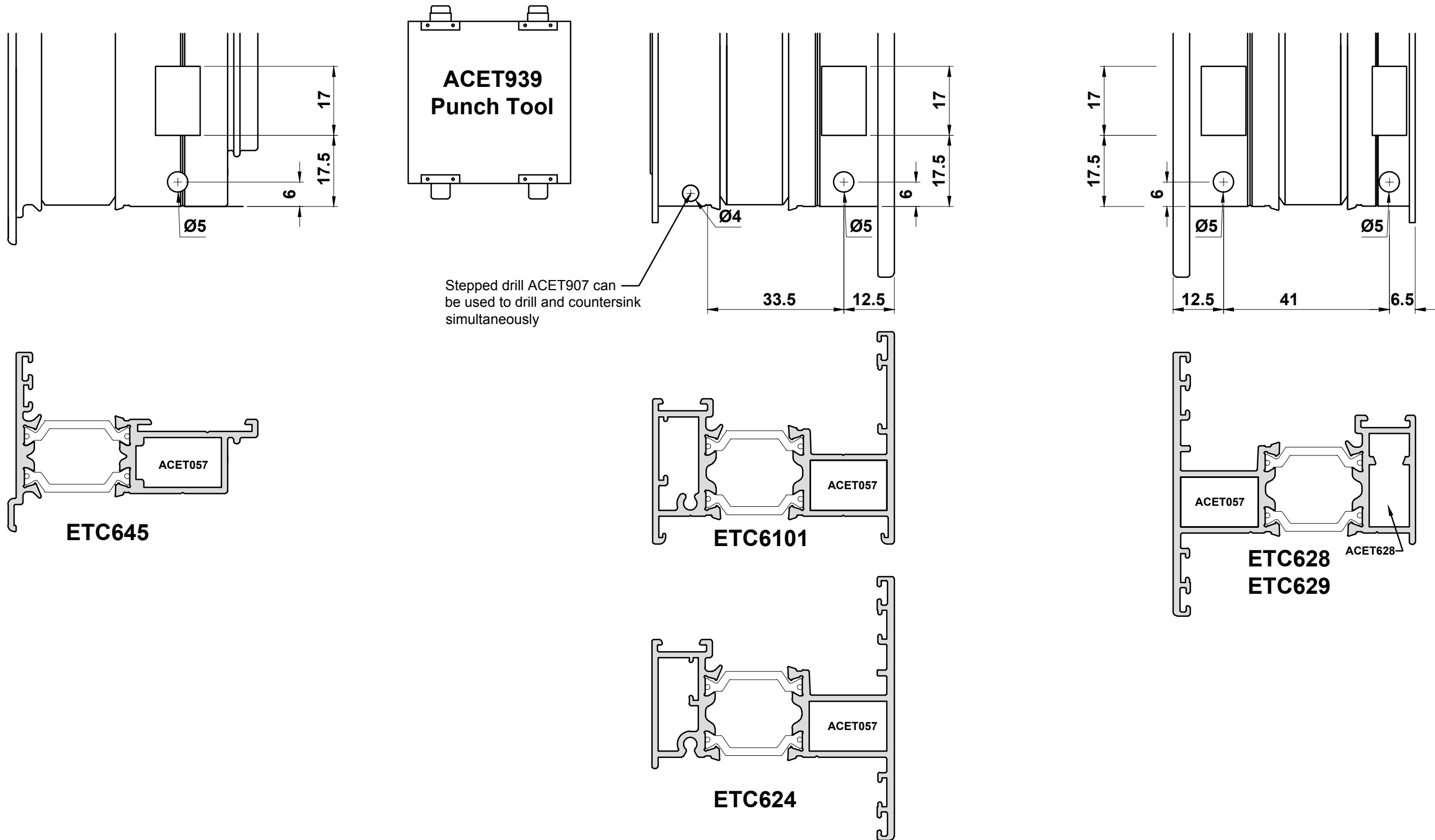
Do Not Scale From This Drawing

Corner Assembly - Mechanical Cleats



Do Not Scale From This Drawing

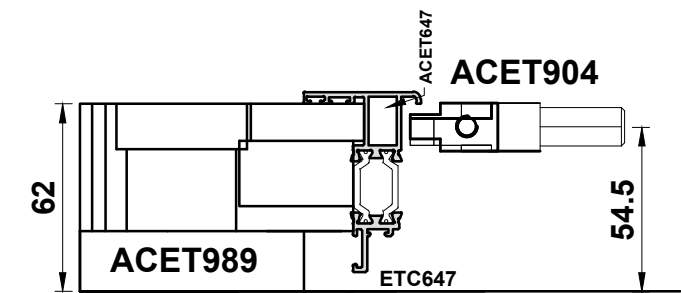
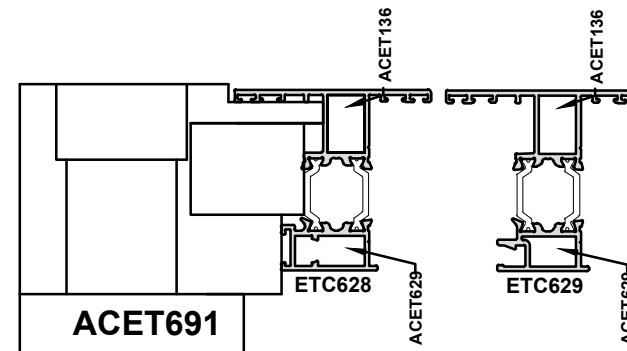
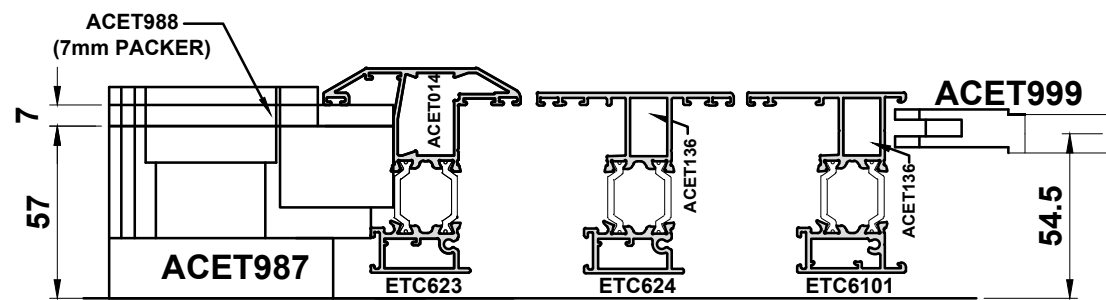
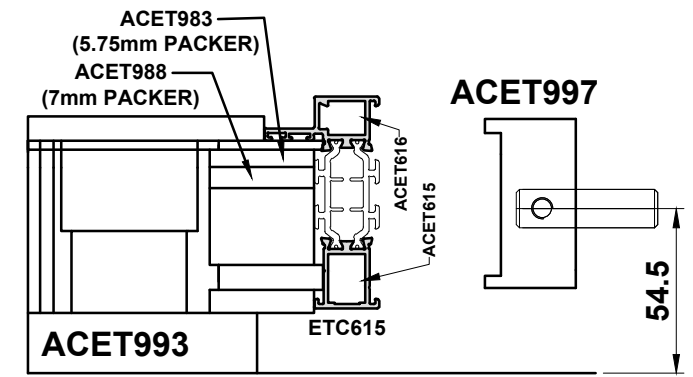
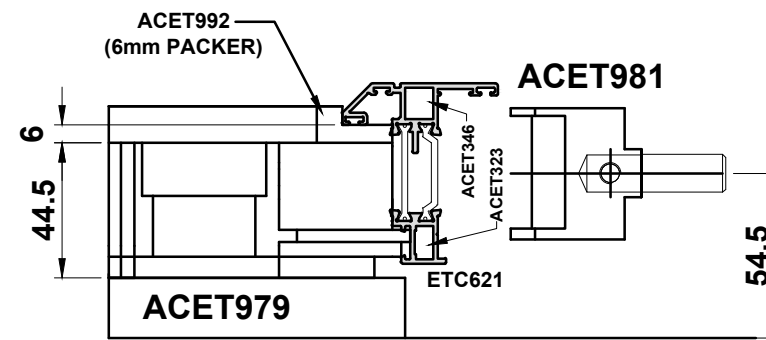
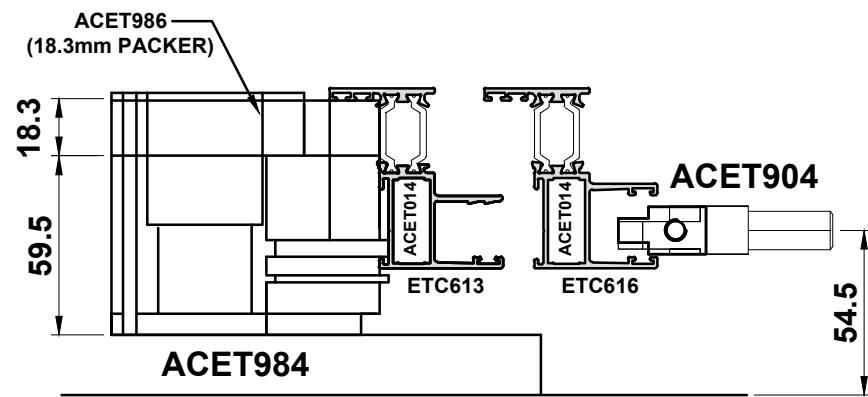
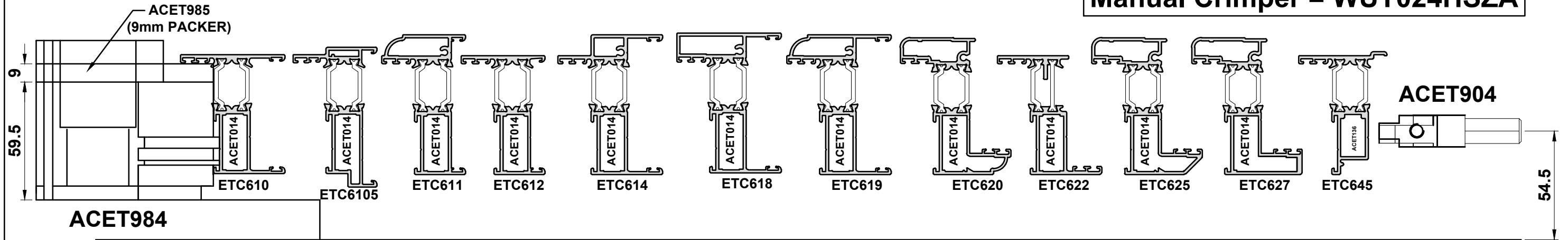
Corner Assembly - Mechanical Cleats



Do Not Scale From This Drawing

Corner Assembly - Crimping Cleats

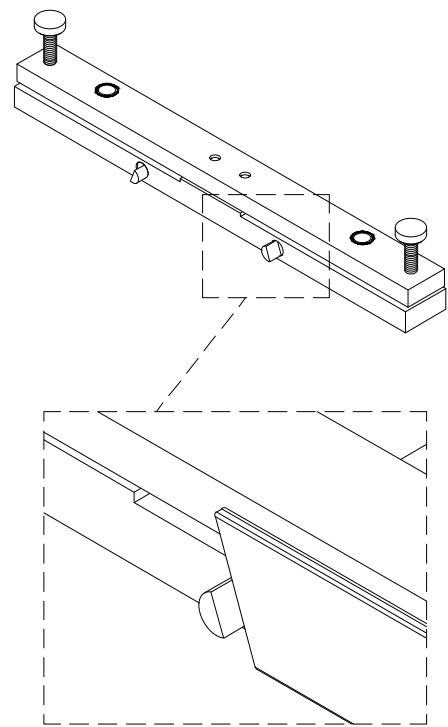
Manual Crimper = WUT024HSZA



Do Not Scale From This Drawing

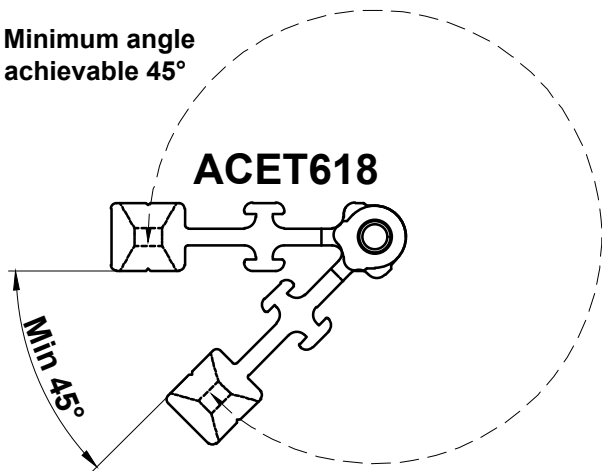
Corner Assembly - Vari-Angle

For ACET618 Vari-Angle Cleat use ACET692 Drilling Jig.

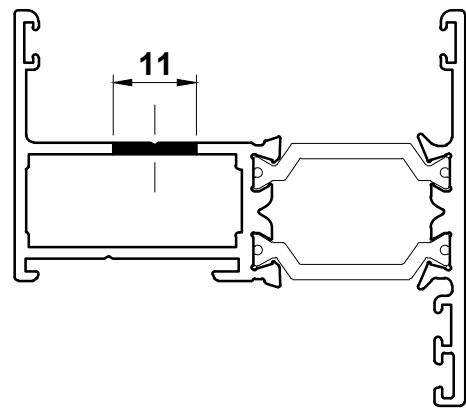


Ensure mitred face of profile is touching flat face of rotating pin in ACET692, then tighten security screw.

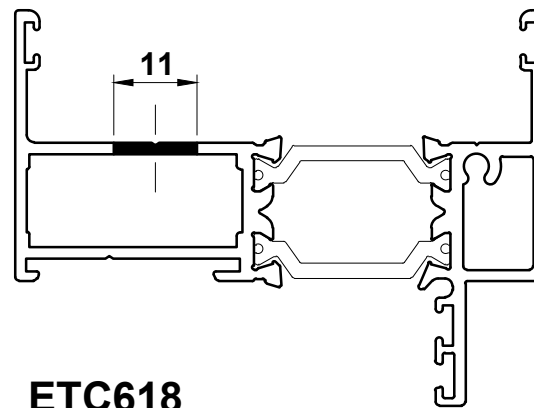
Minimum angle achievable 45°



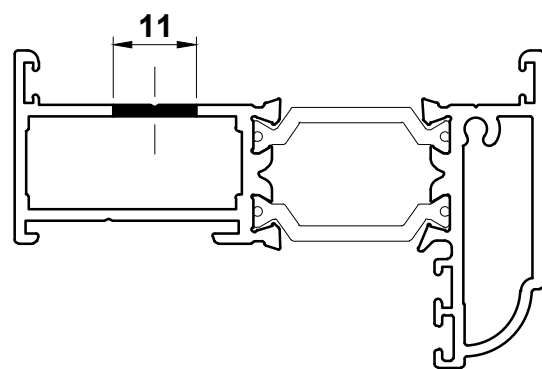
ETC610



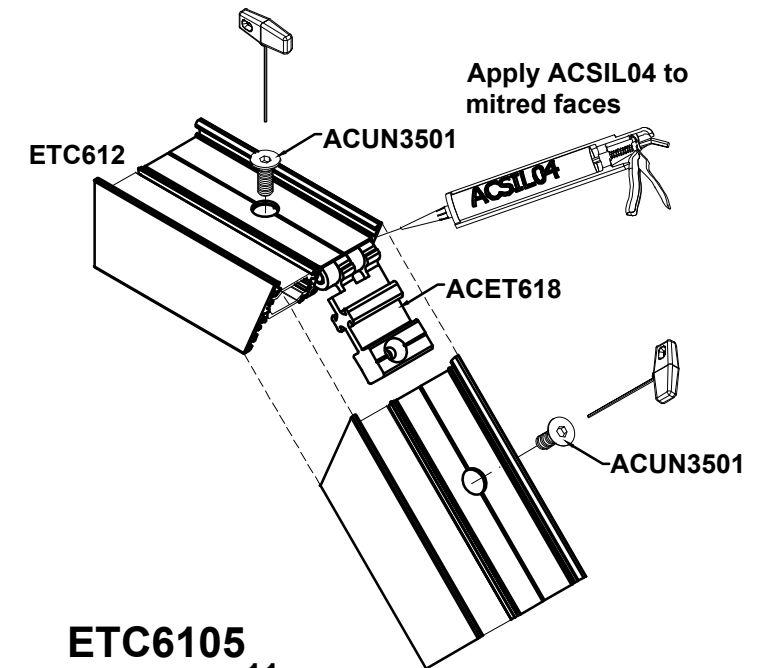
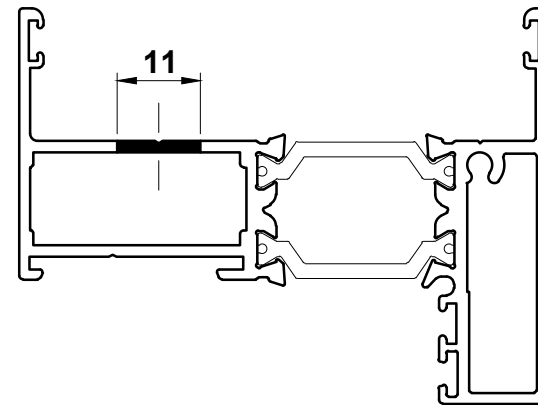
ETC614



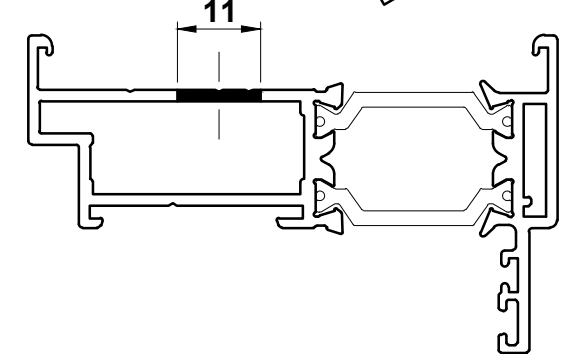
ETC611



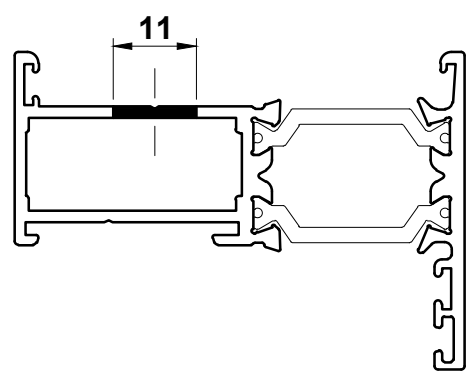
ETC618



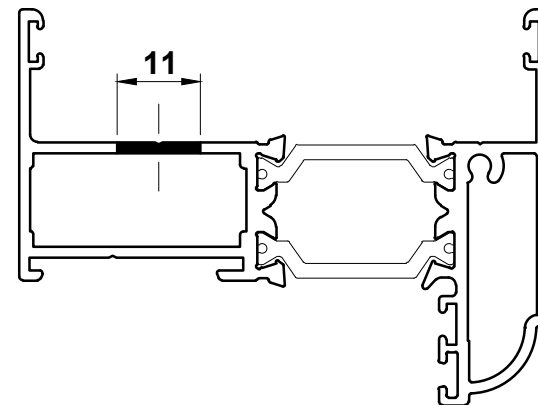
ETC6105



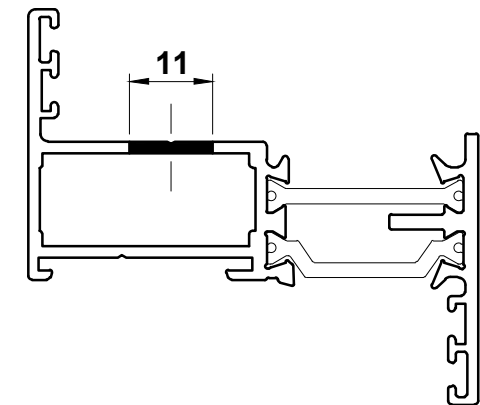
ETC612



ETC619



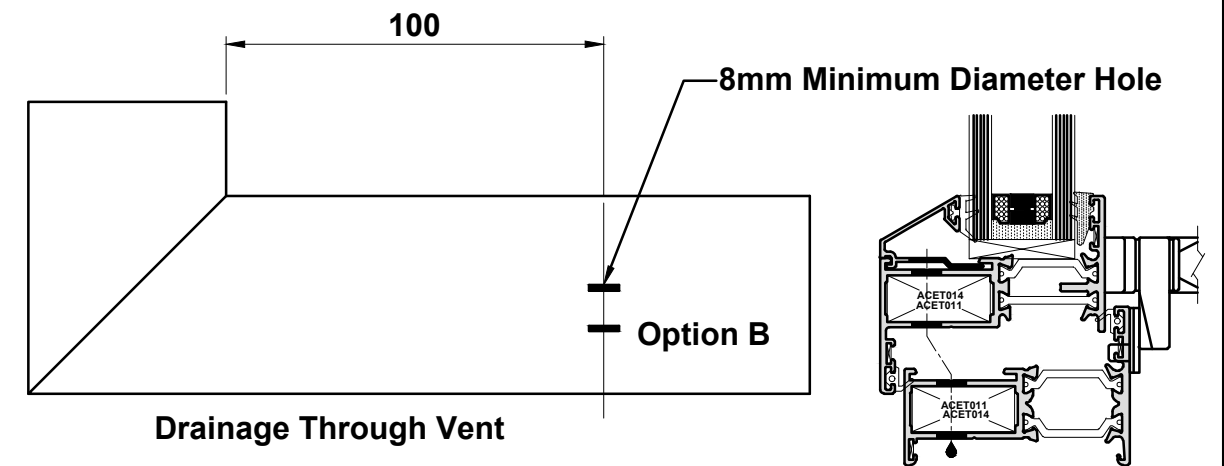
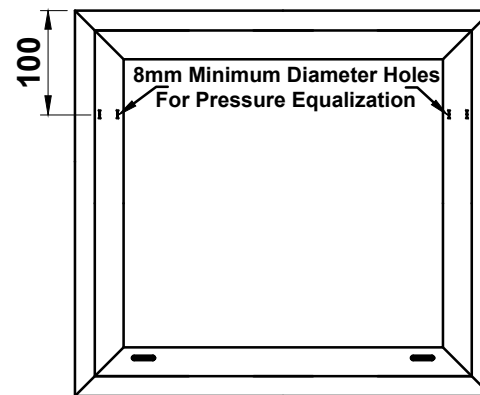
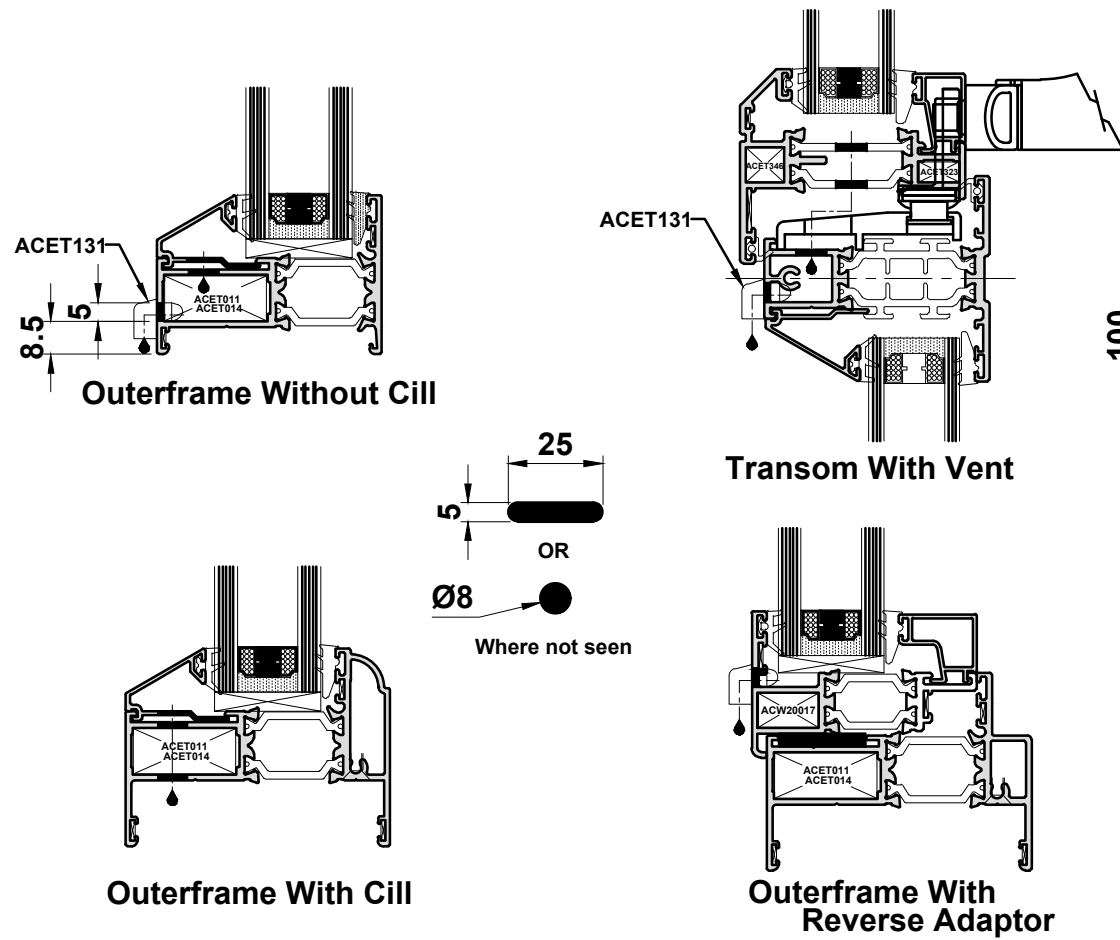
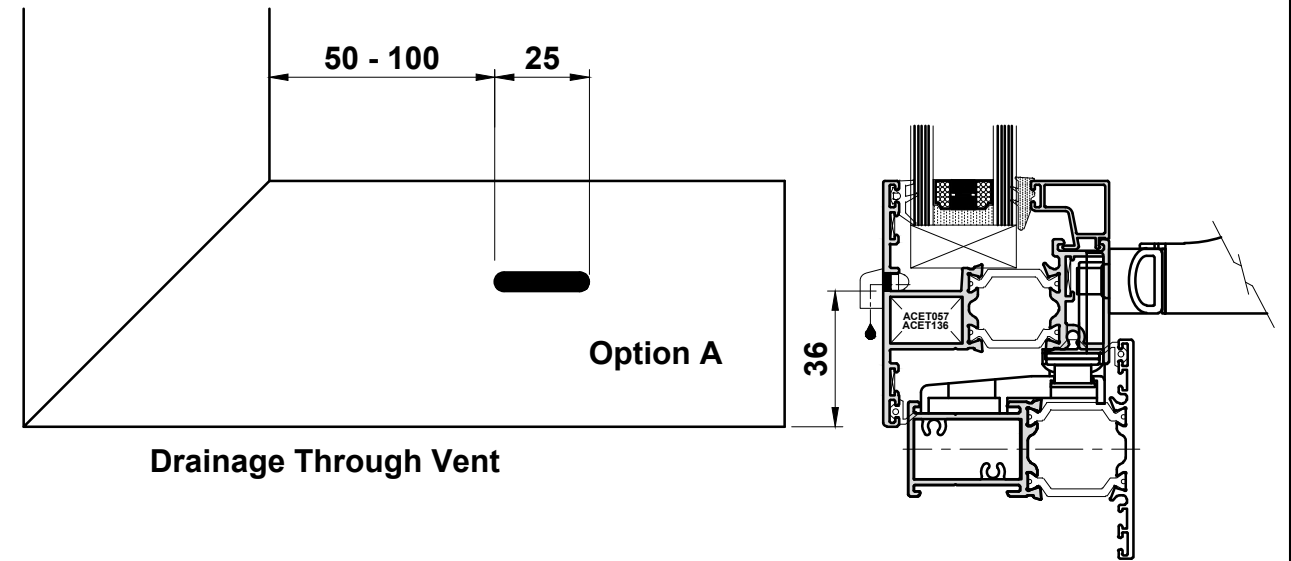
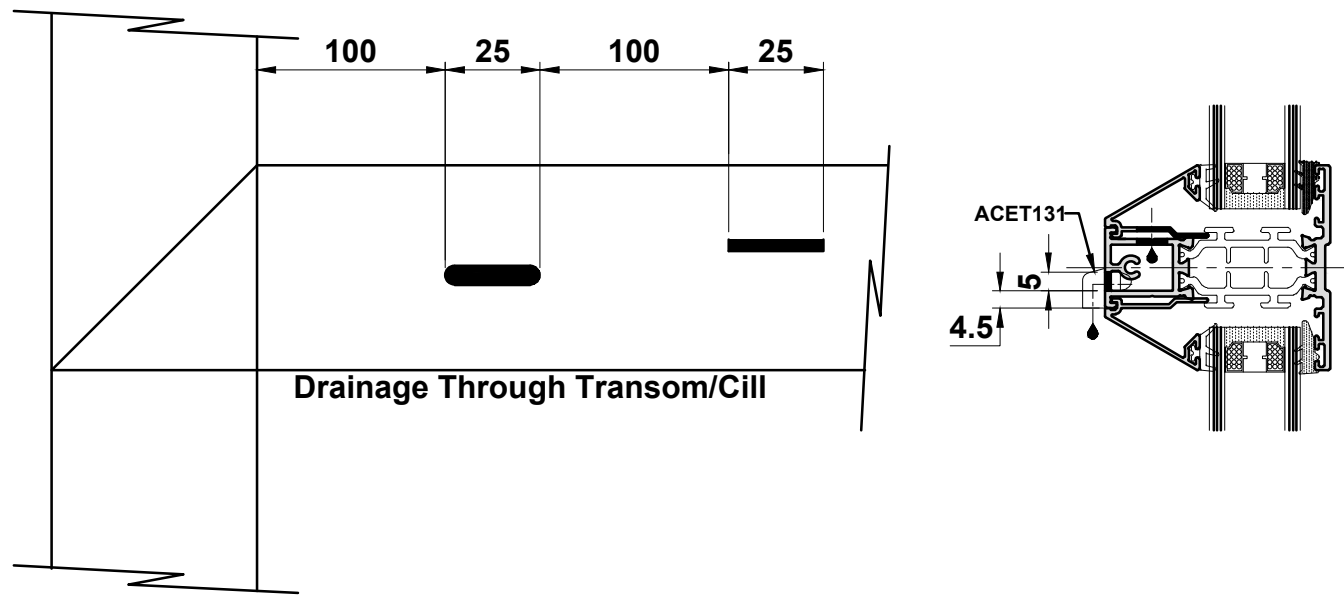
ETC622



Note: Pre-Drill through ACET692 hole with Ø5mm drill before removing jig and drilling Ø11mm hole.

Do Not Scale From This Drawing

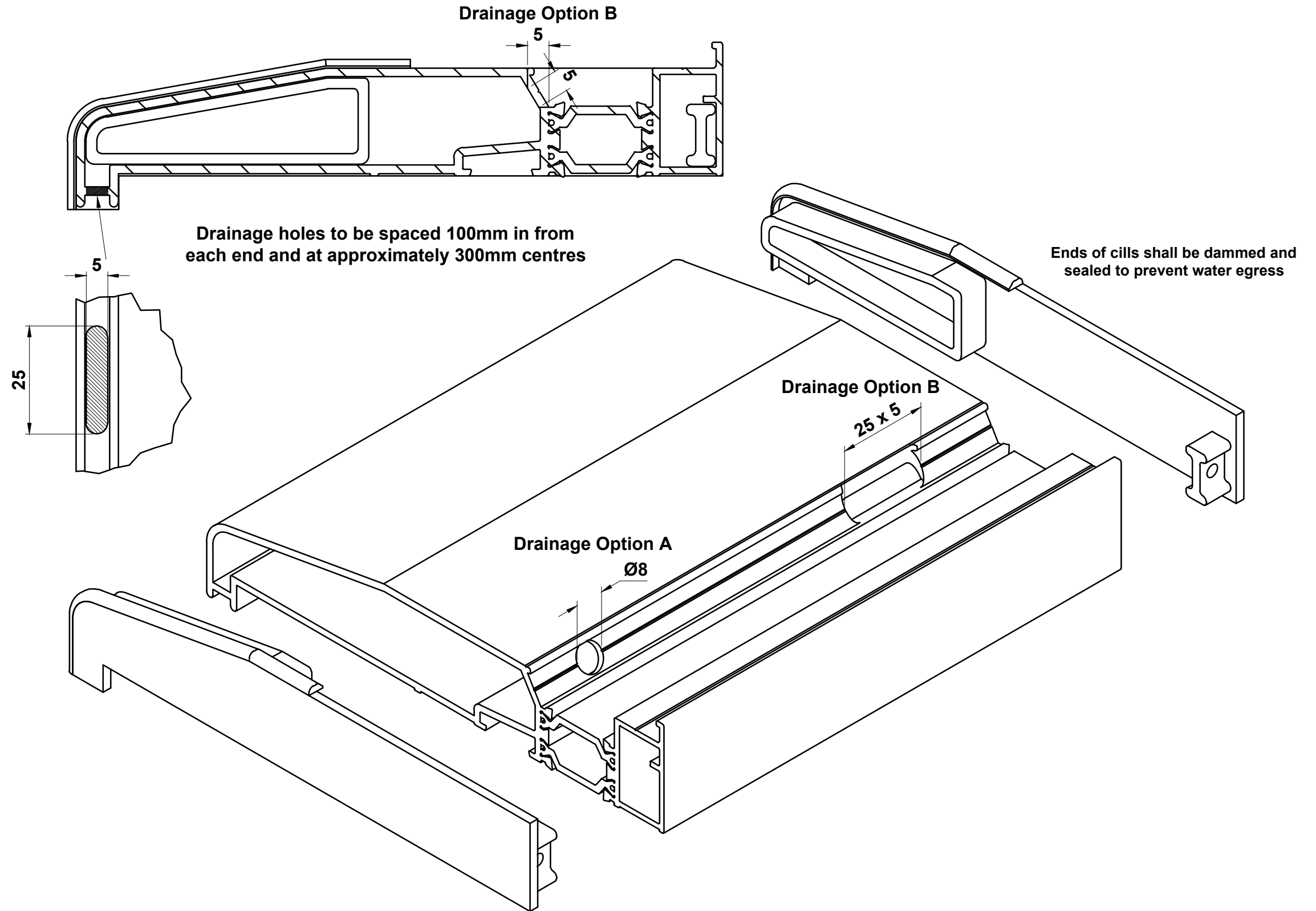
Drainage



Important Note: All exposed aluminium should be coated using ACSIL014 or painted to match the frame.

Do Not Scale From This Drawing

Sub Cill Drainage

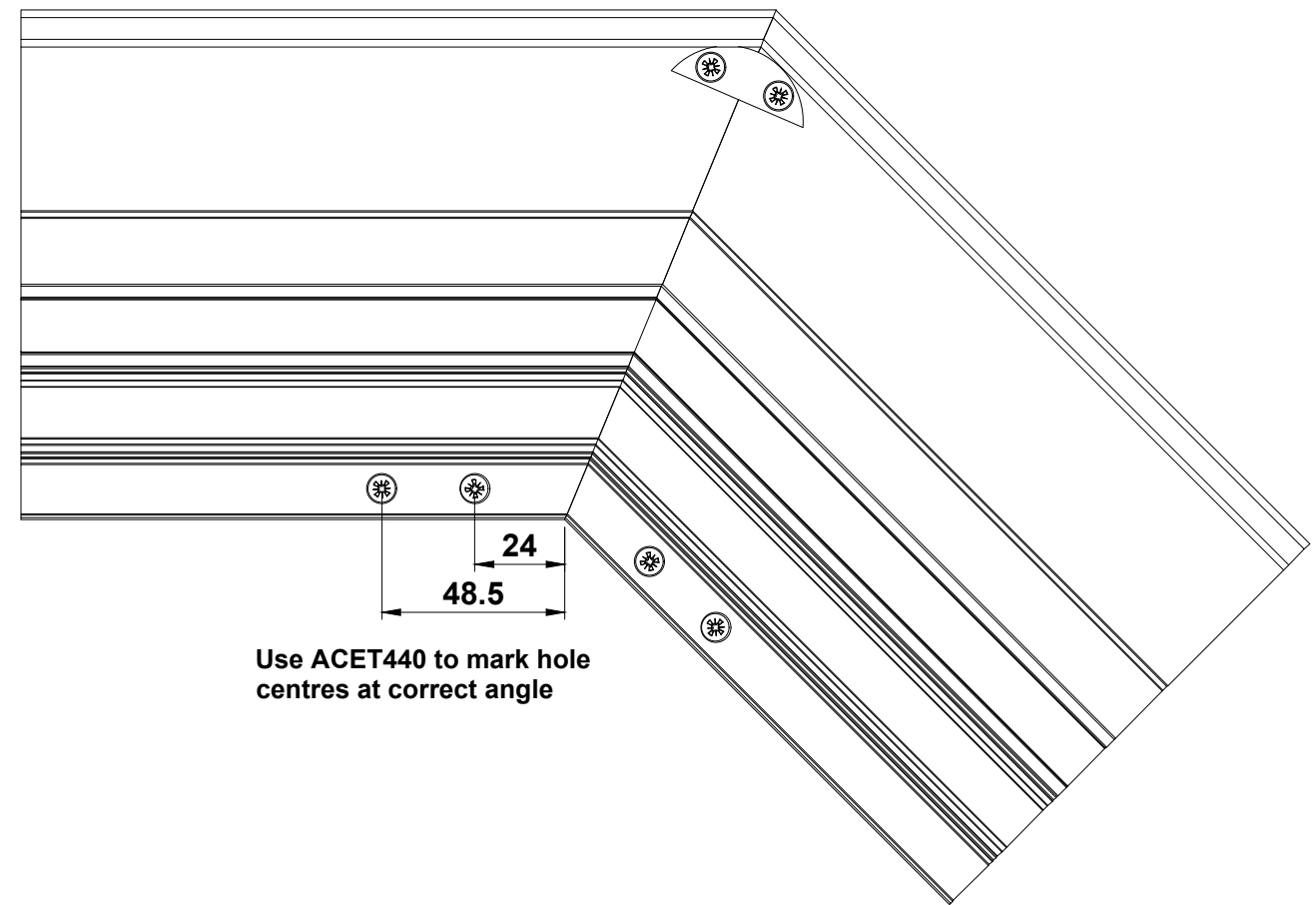
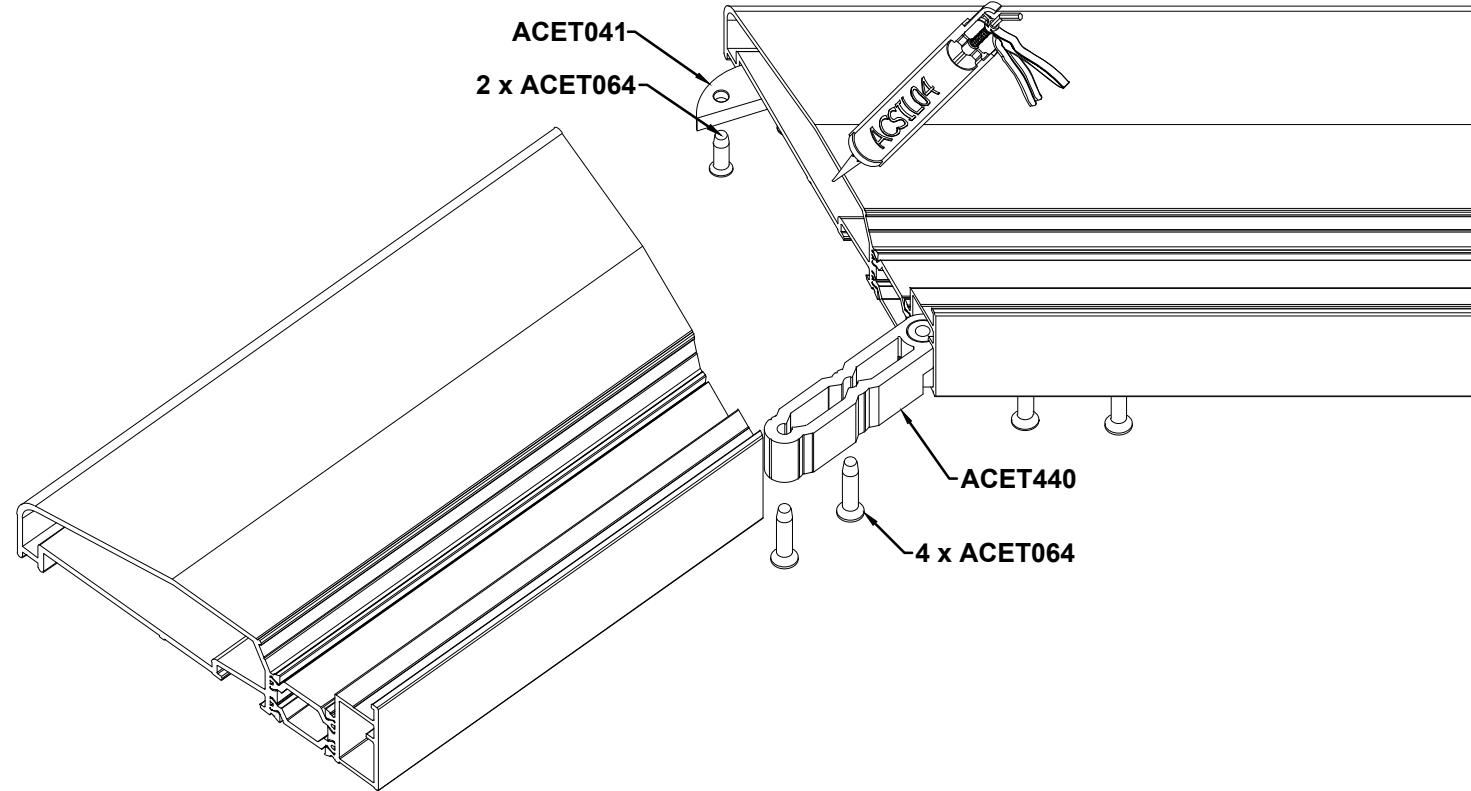


Do Not Scale From This Drawing

90° - 180° Angled Sub Cill

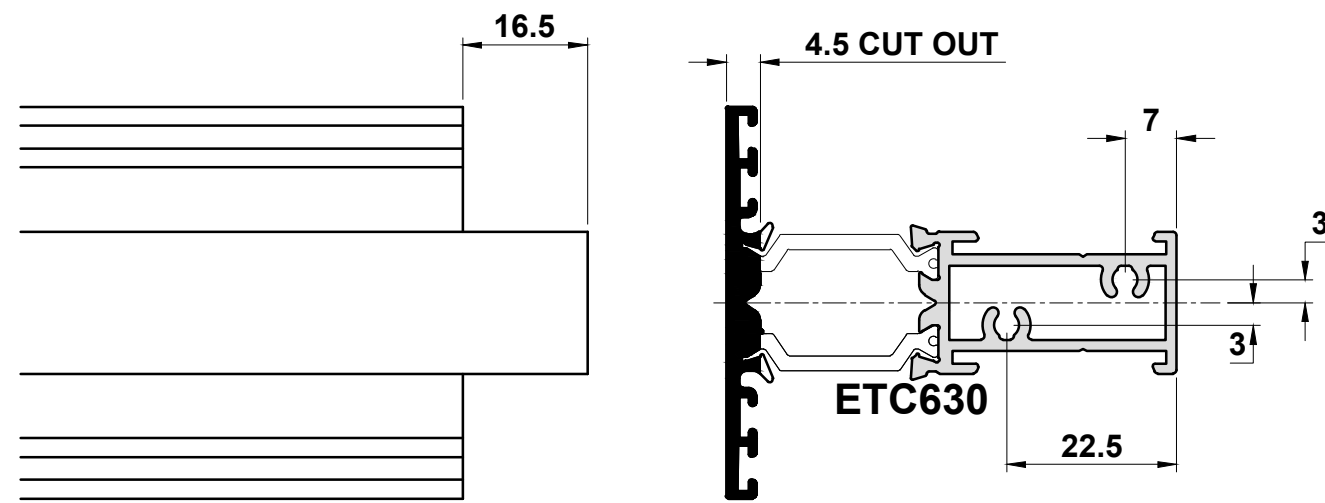
This detail is suitable for: ETC451, ETC452, ETC457, ETC458 and ETC479

End of cills must be dammed and sealed to prevent water egress.

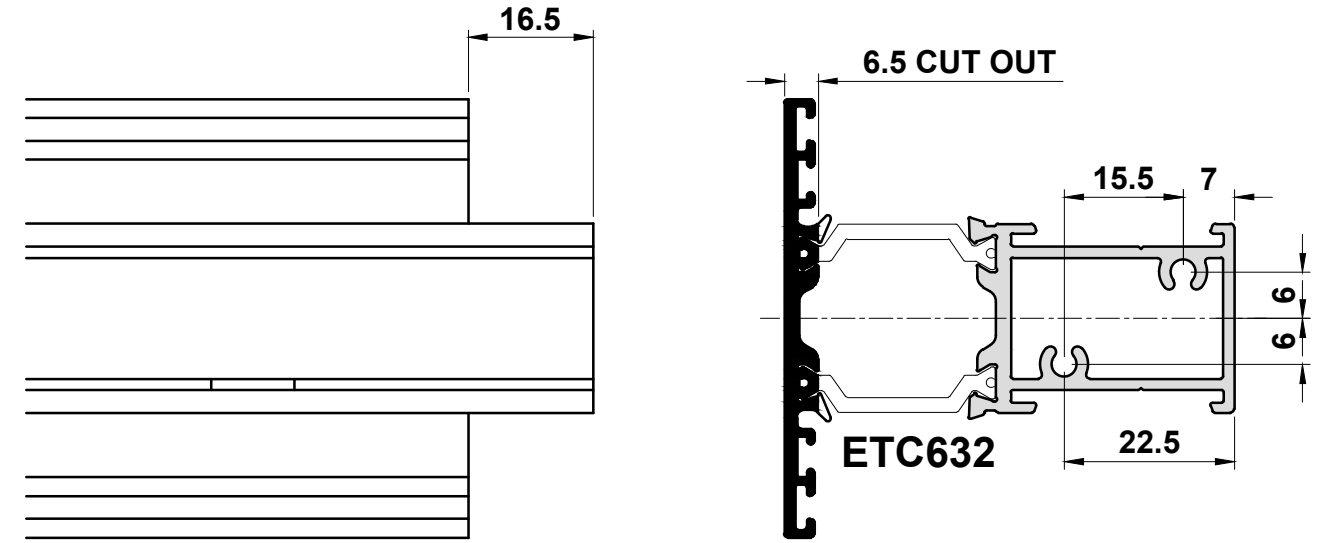


Do Not Scale From This Drawing

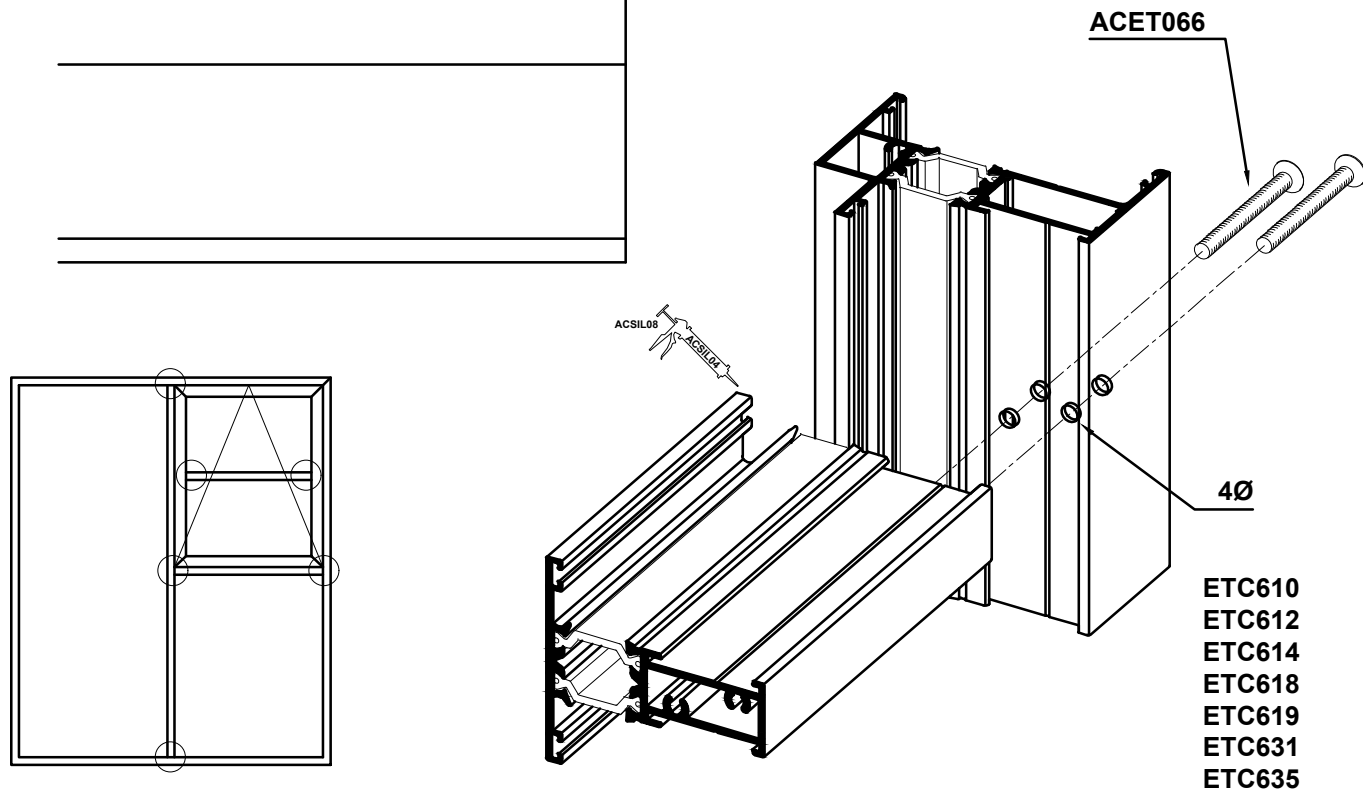
Transom/Mullion Preparation



To ensure accuracy
use recommended
drill jigs-
ETC630-ACET908



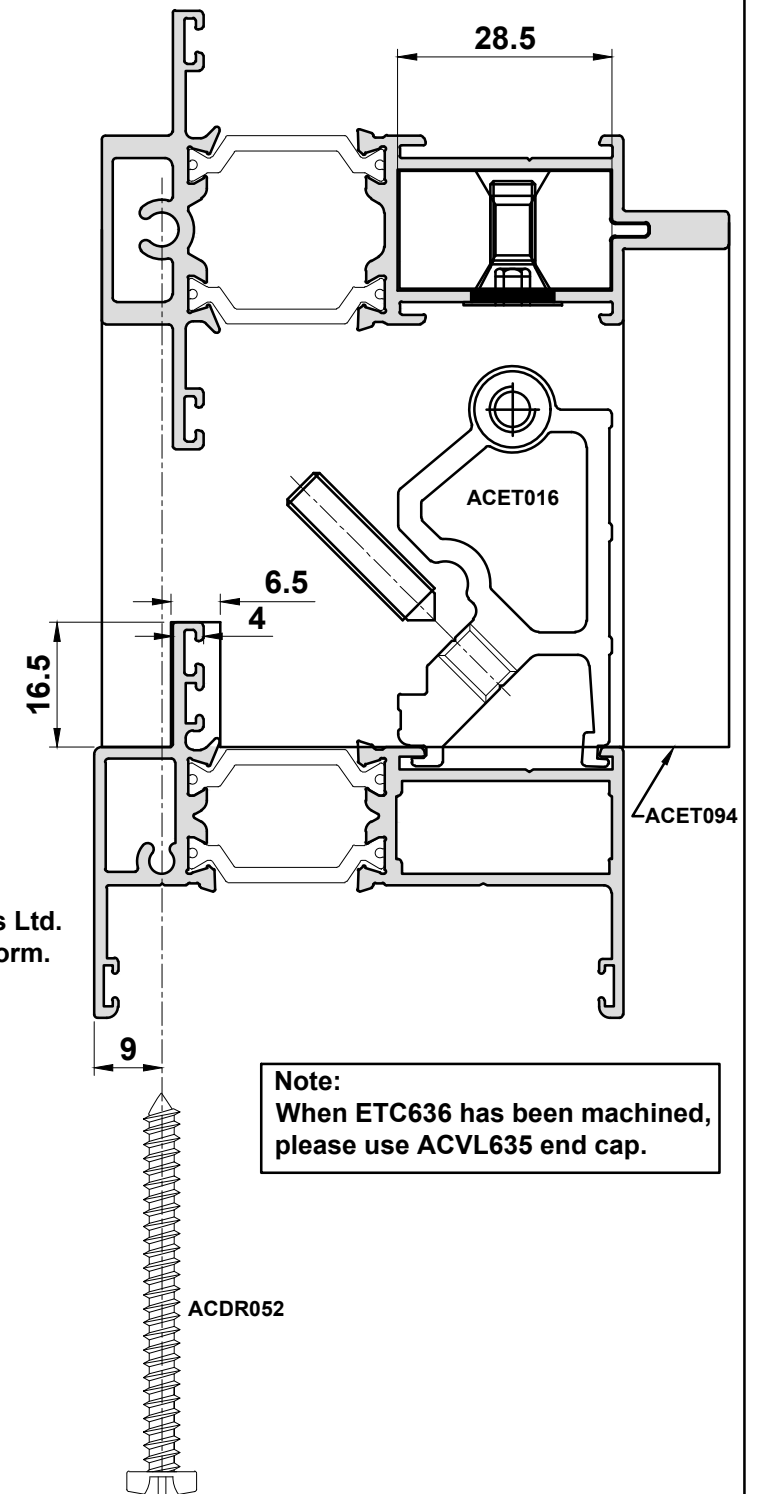
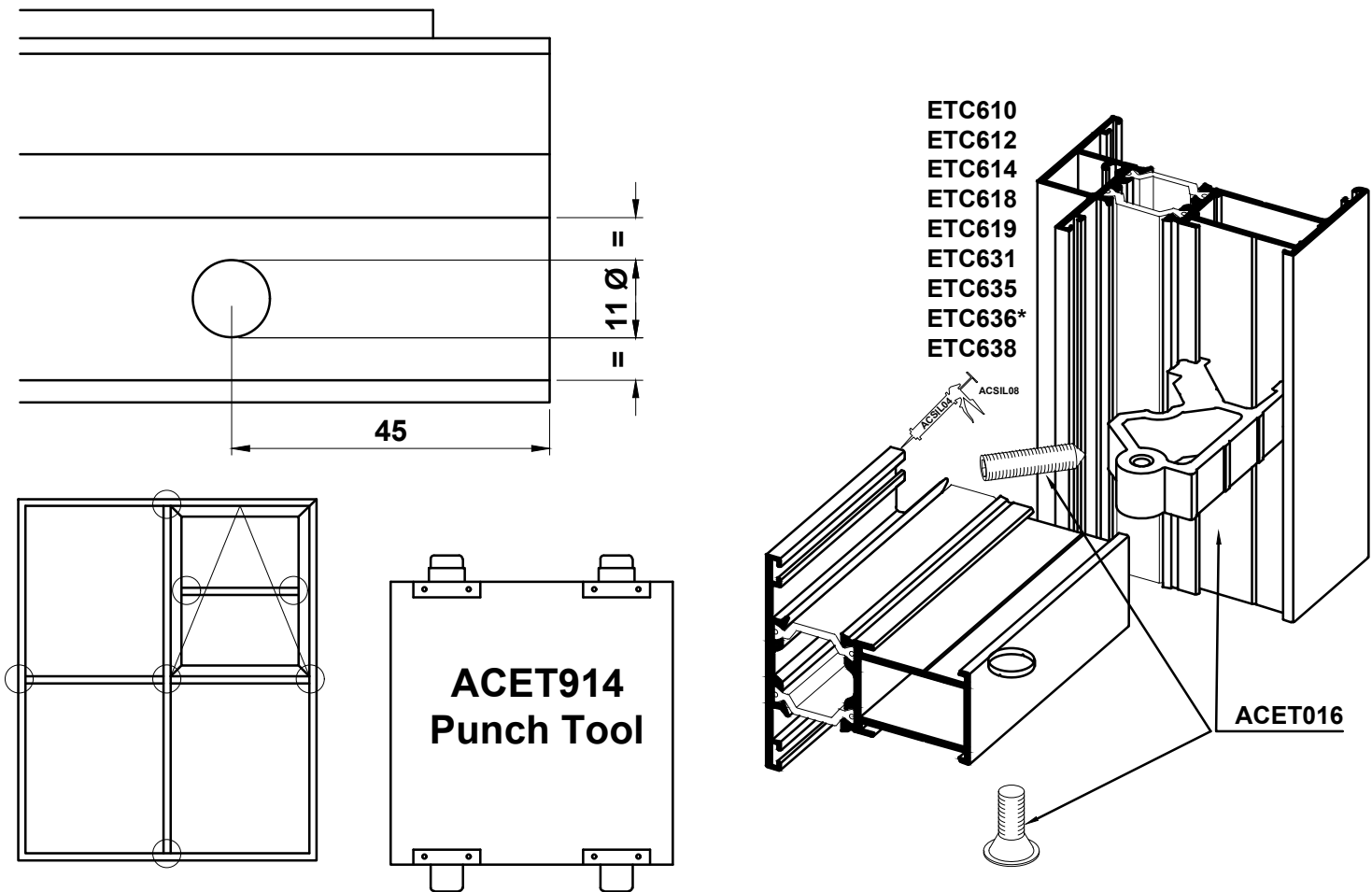
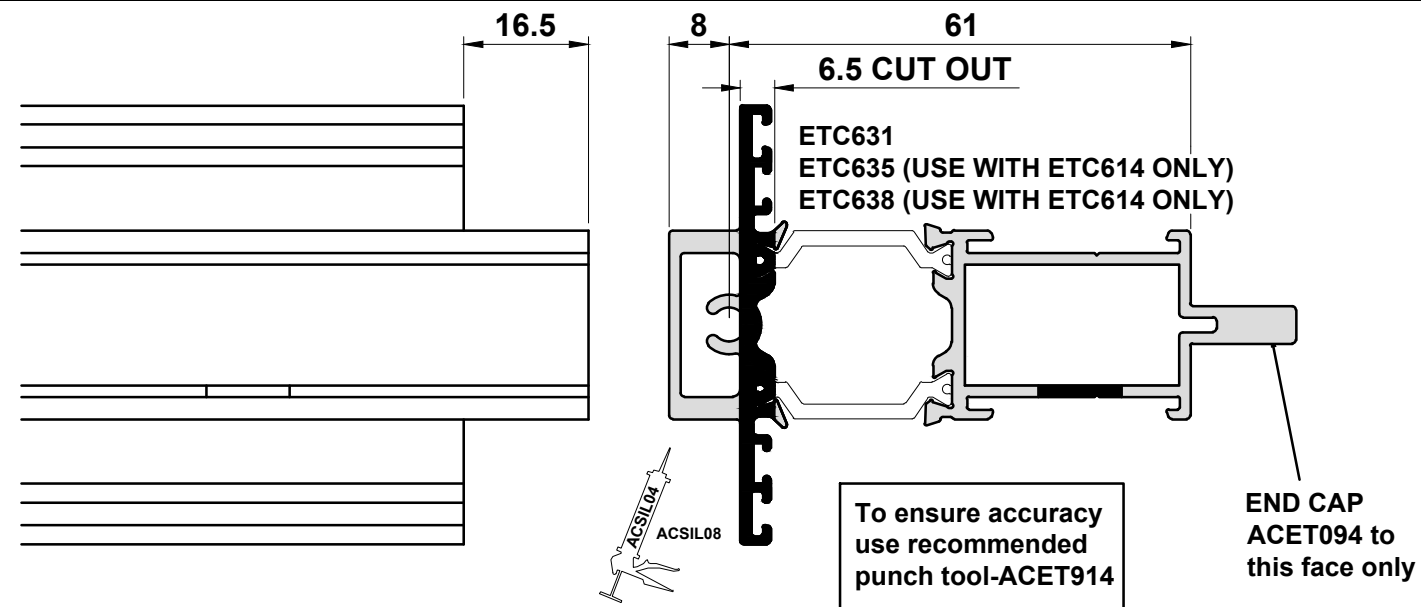
To ensure accuracy
use recommended
drill jigs-
ETC632-ACET910



Note:
End mill cutters can be ordered through Smart Systems Ltd.
Please contact the Technical Department for an order form.
Standard delivery is 2-3 weeks approx.

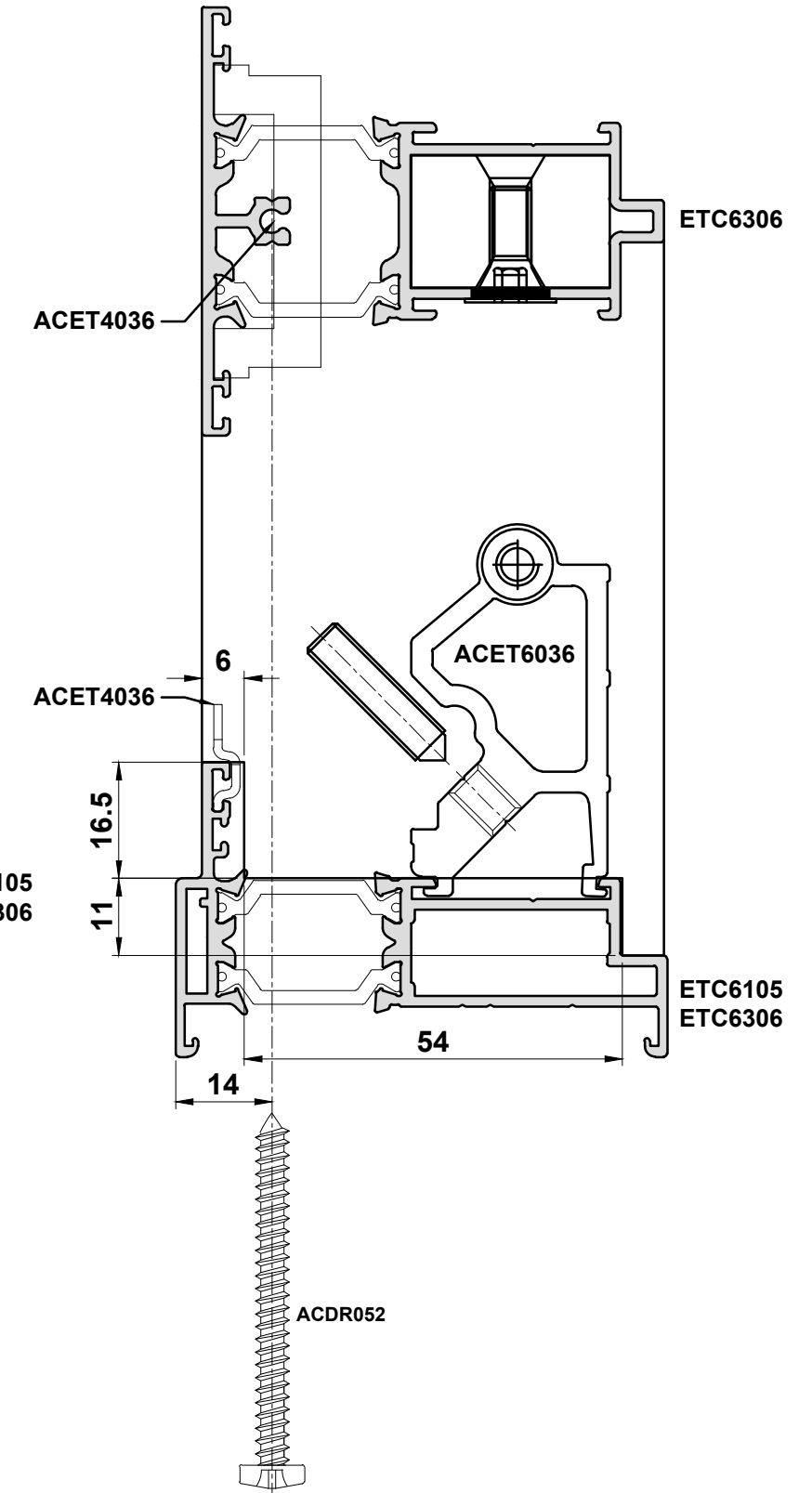
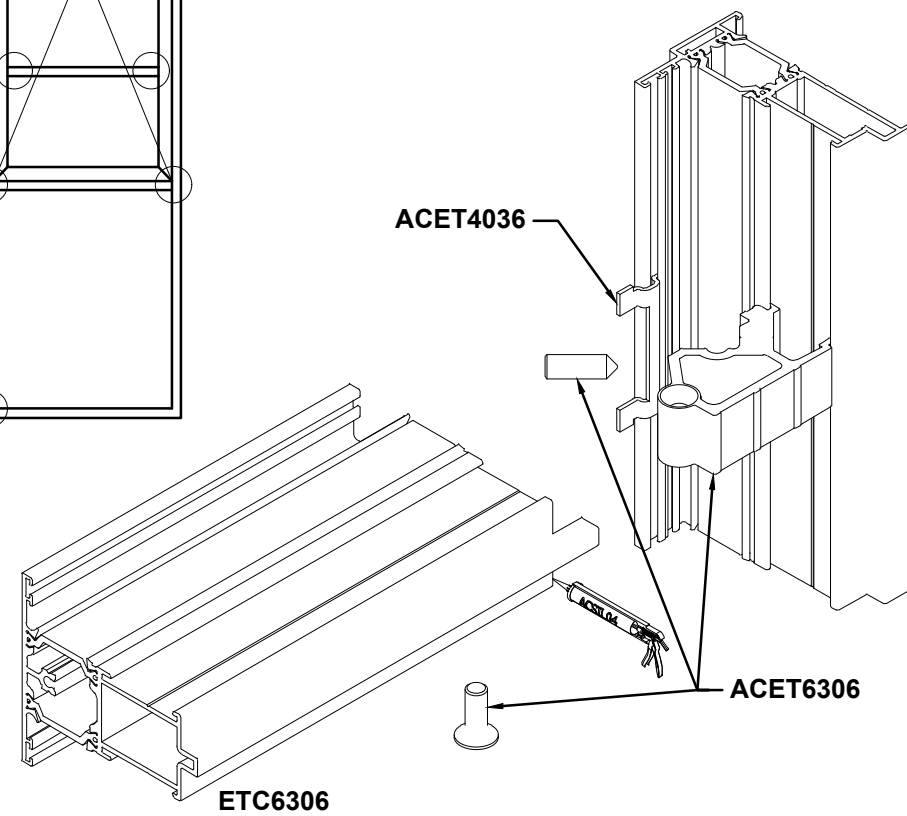
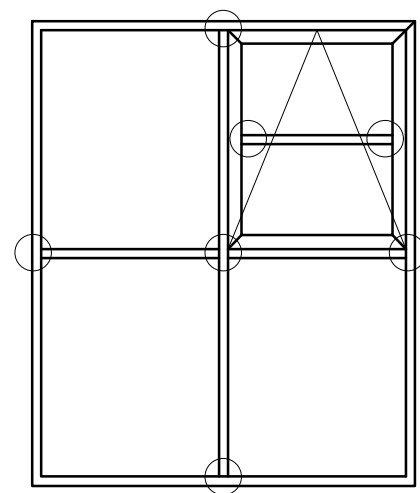
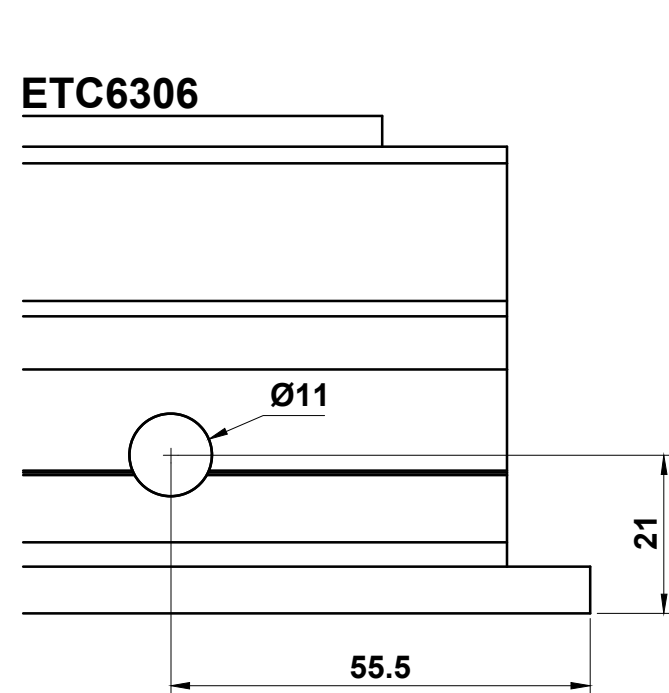
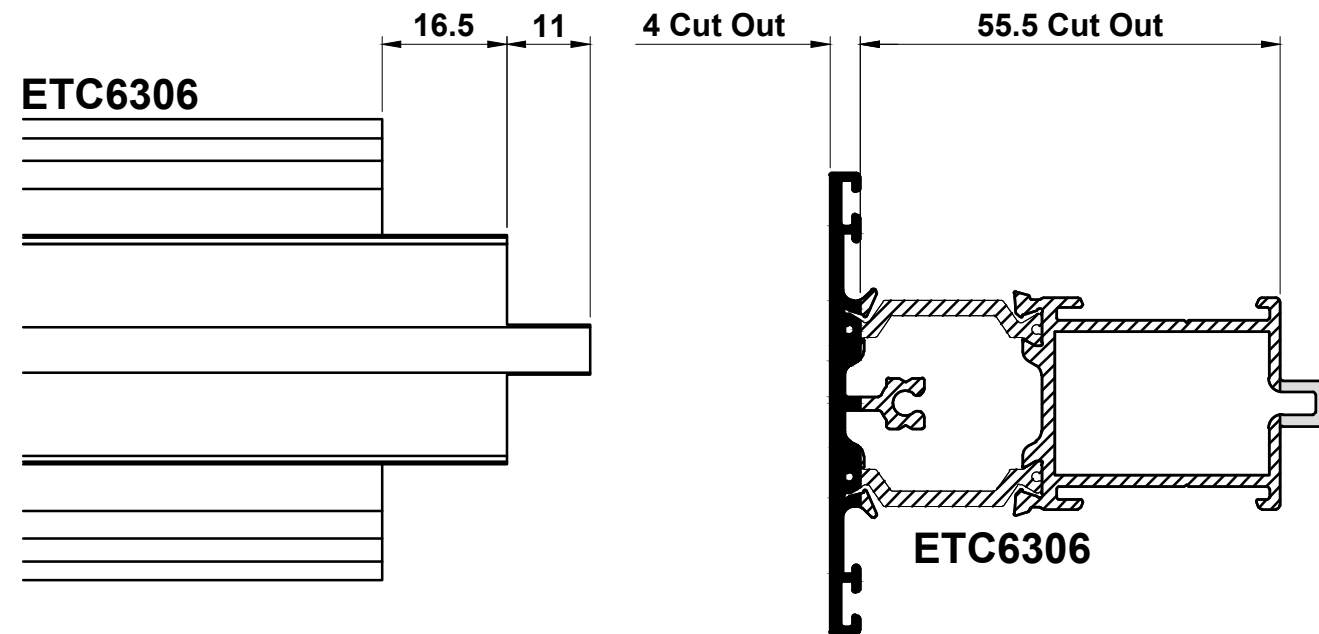
Do Not Scale From This Drawing

Transom/Mullion Preparation



Do Not Scale From This Drawing

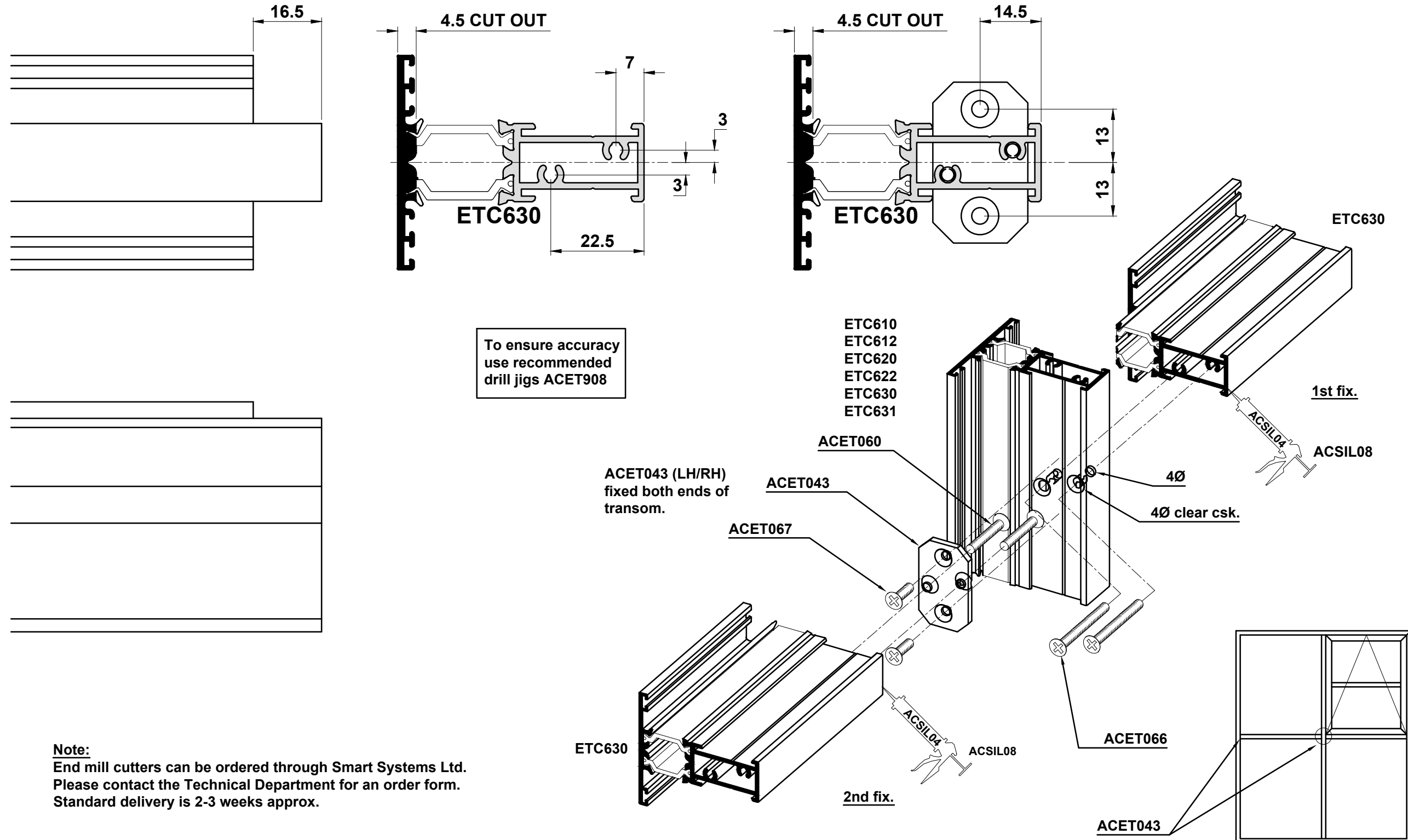
Transom/Mullion Preparation



Note:
End mill cutters can be ordered through Smart Systems Ltd.
Please contact the Technical Department for an order form.
Standard delivery is 2-3 weeks approx.

Do Not Scale From This Drawing

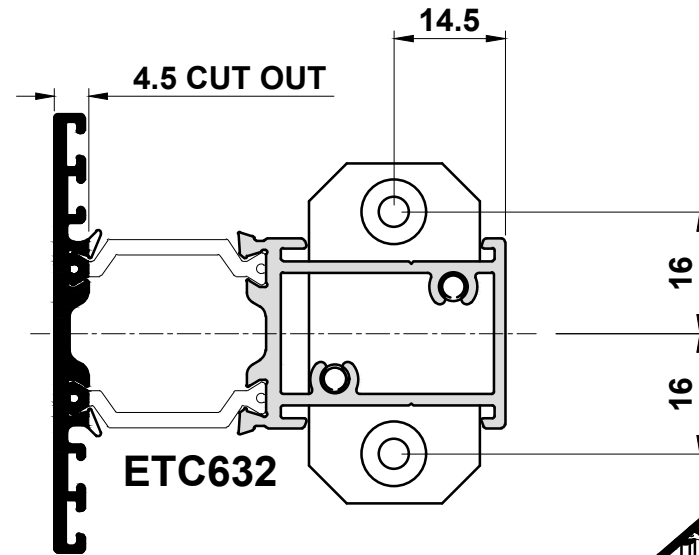
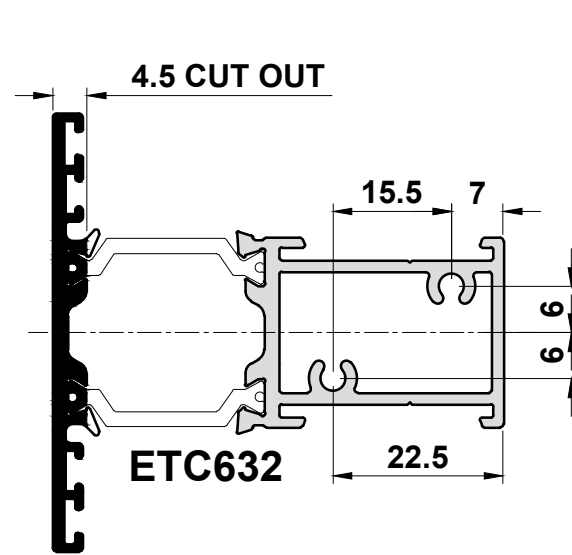
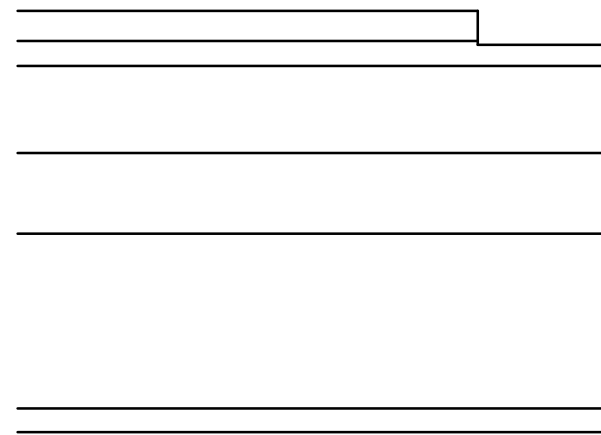
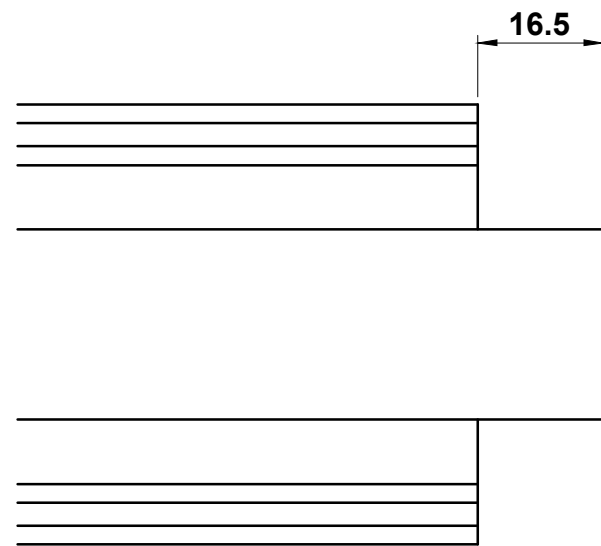
Transom/Mullion Preparation



Note:
End mill cutters can be ordered through Smart Systems Ltd.
Please contact the Technical Department for an order form.
Standard delivery is 2-3 weeks approx.

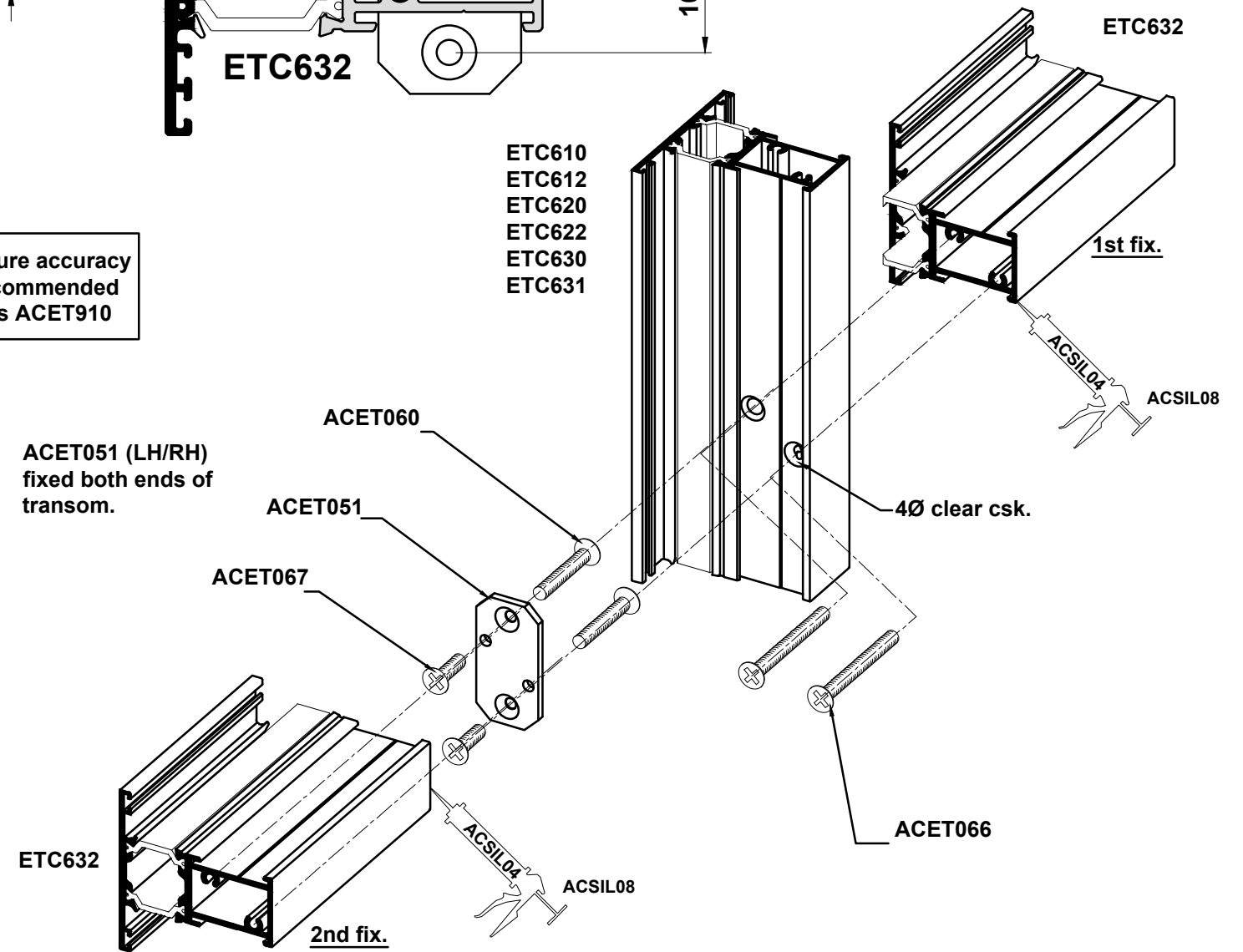
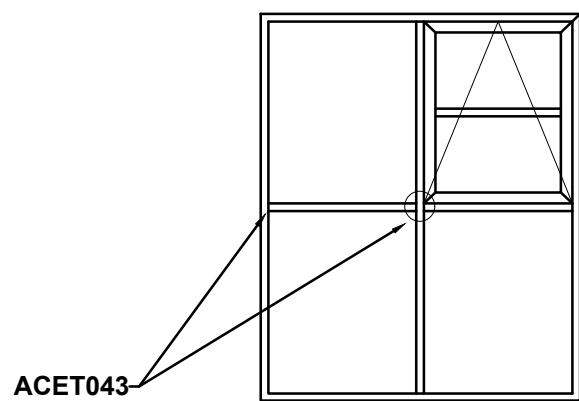
Do Not Scale From This Drawing

Transom/Mullion Preparation



To ensure accuracy use recommended drill jigs ACET910

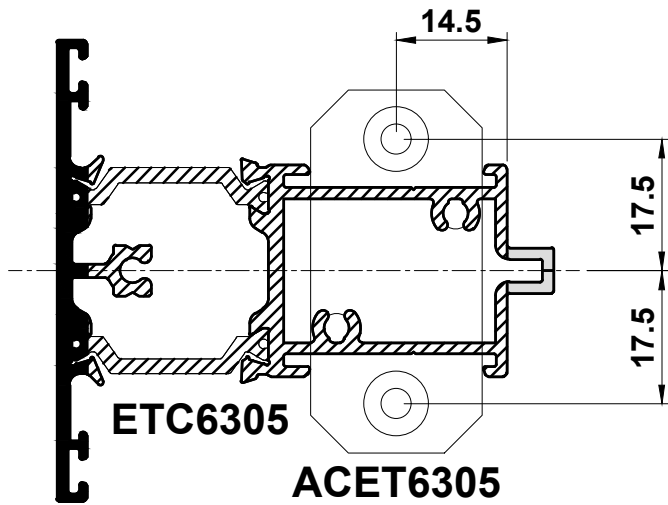
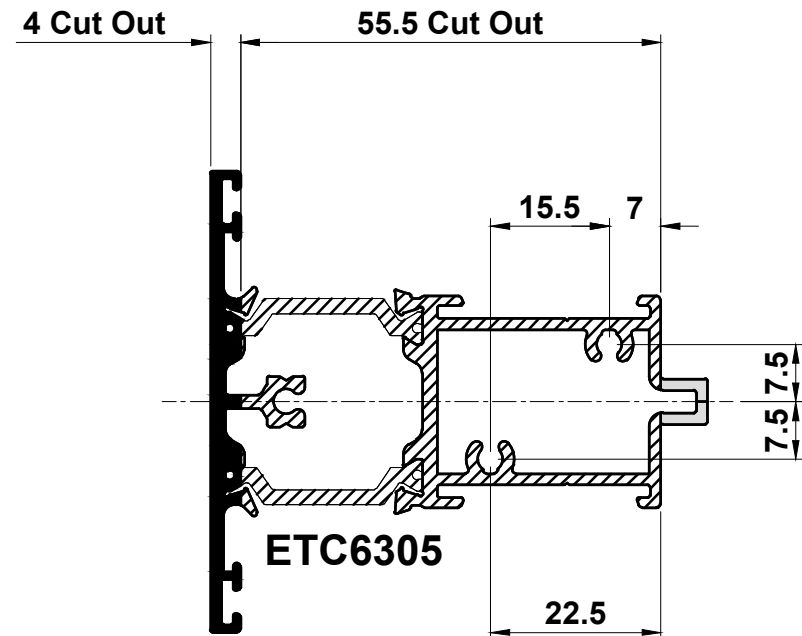
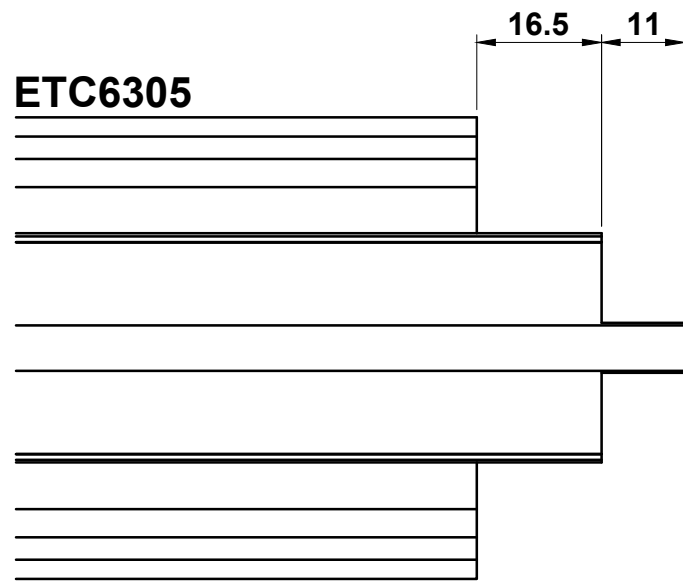
- ETC610
- ETC612
- ETC620
- ETC622
- ETC630
- ETC631



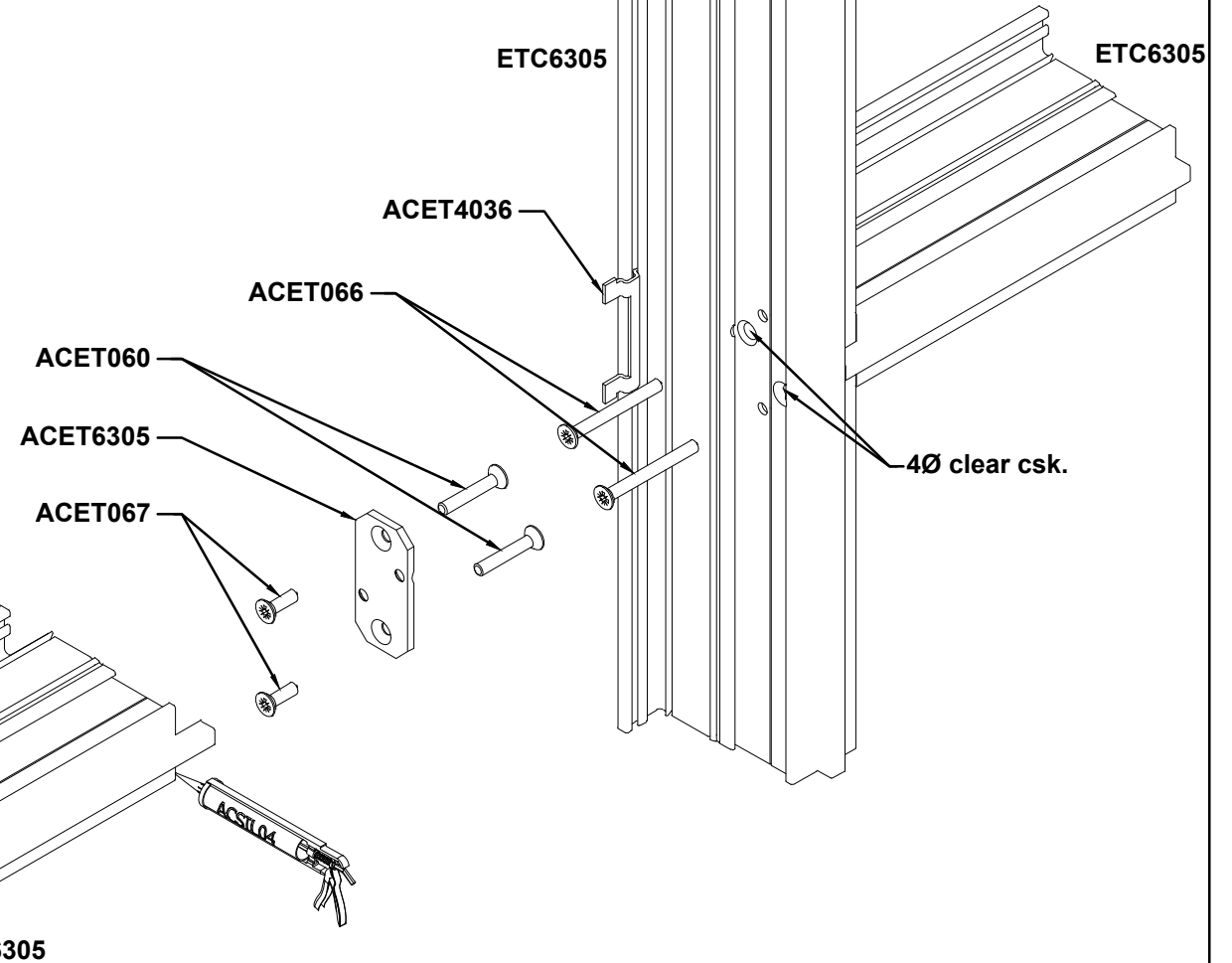
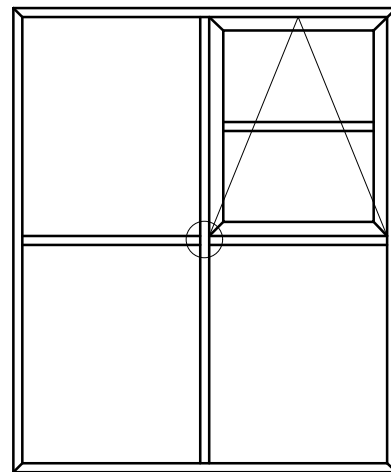
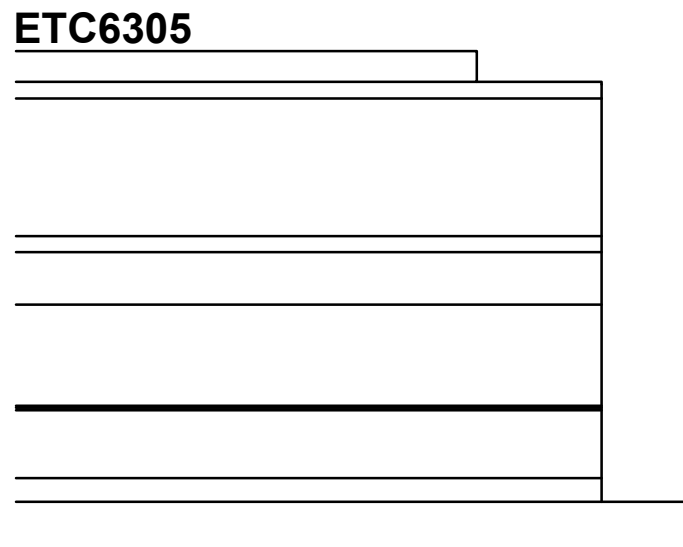
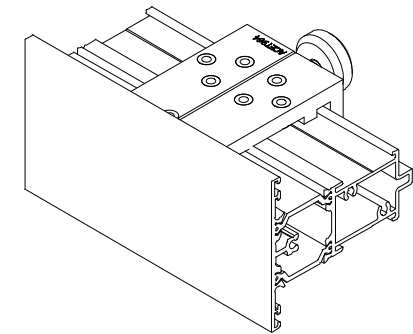
Note:
End mill cutters can be ordered through Smart Systems Ltd.
Please contact the Technical Department for an order form.
Standard delivery is 2-3 weeks approx.

Do Not Scale From This Drawing

Transom/Mullion Preparation



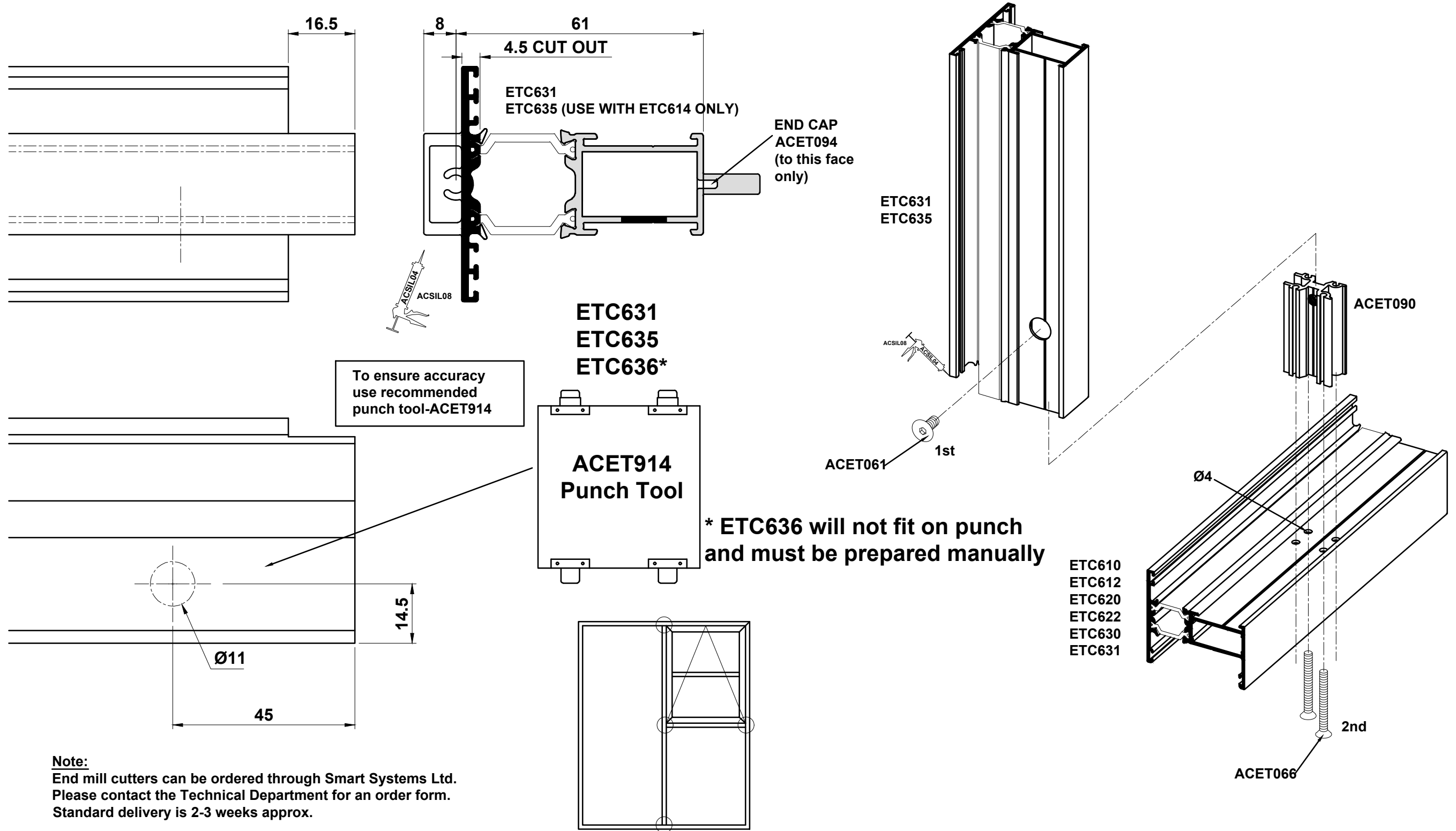
To ensure accuracy use
ACET964 Drill Jig



Note:
End mill cutters can be ordered through Smart Systems Ltd.
Please contact the Technical Department for an order form.
Standard delivery is 2-3 weeks approx.

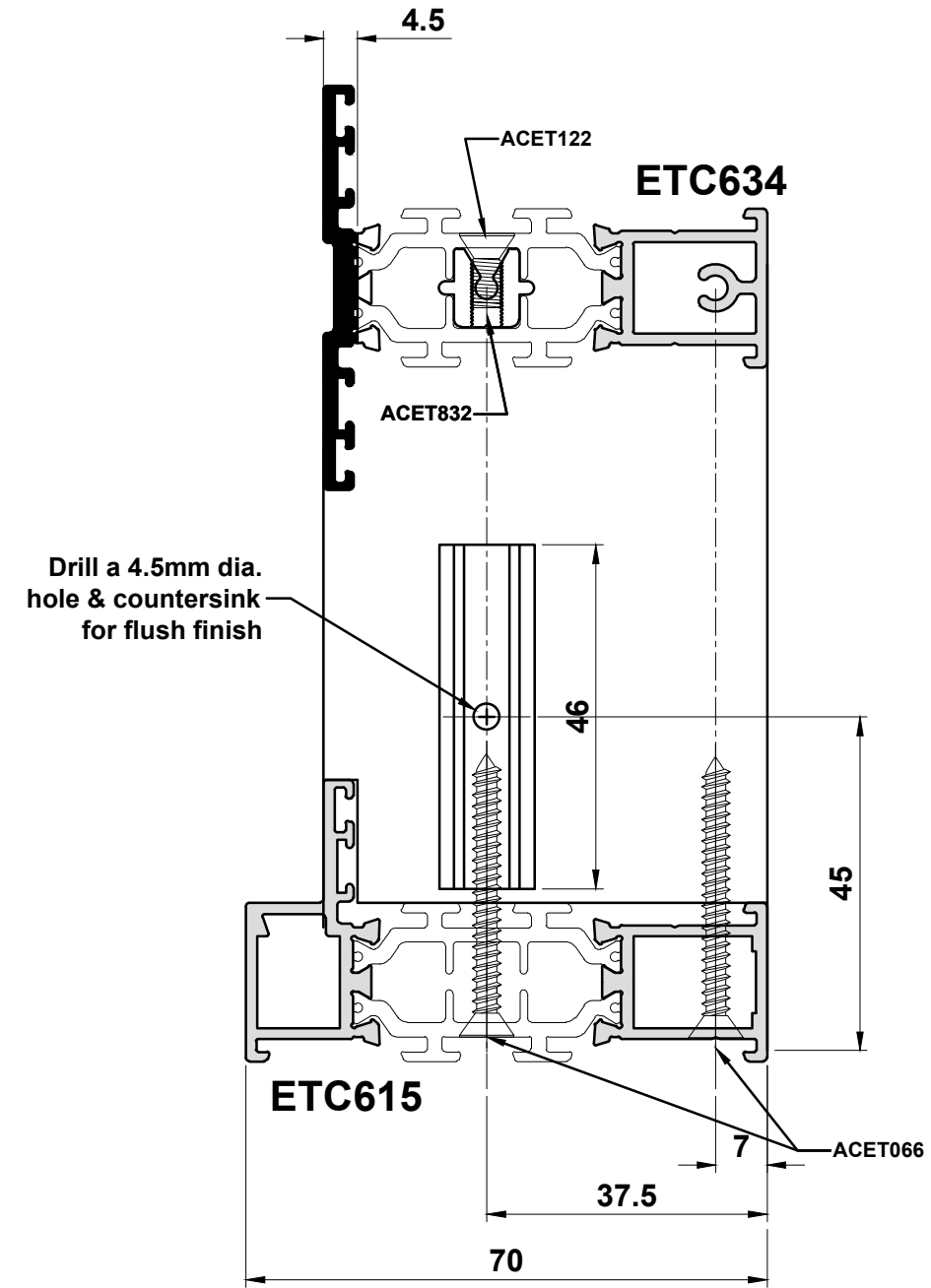
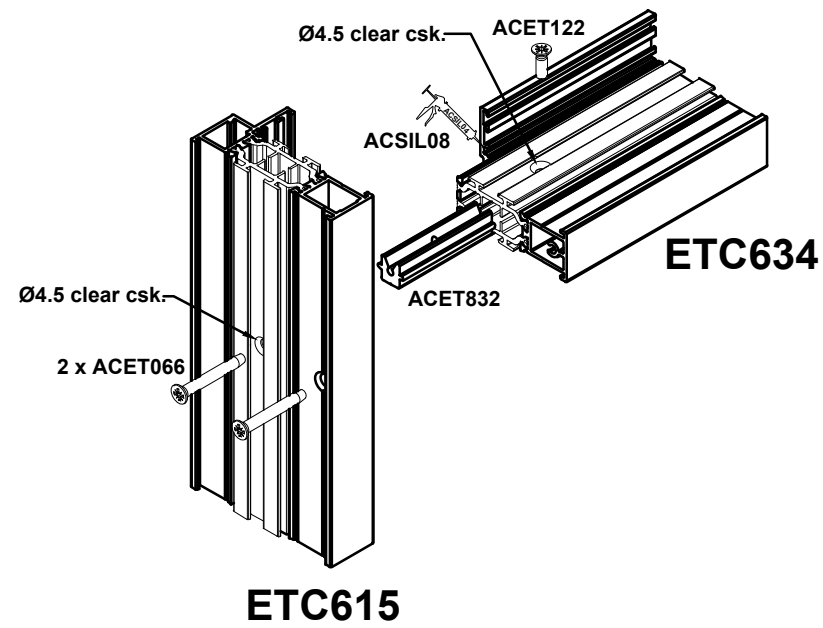
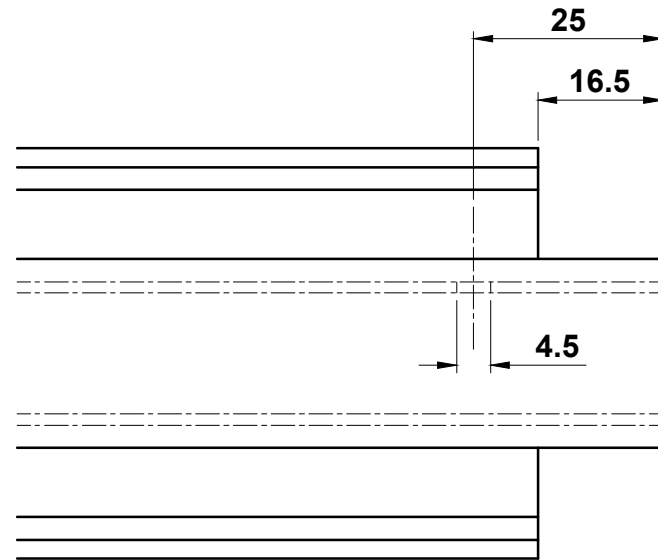
Do Not Scale From This Drawing

Transom/Mullion Preparation



Do Not Scale From This Drawing

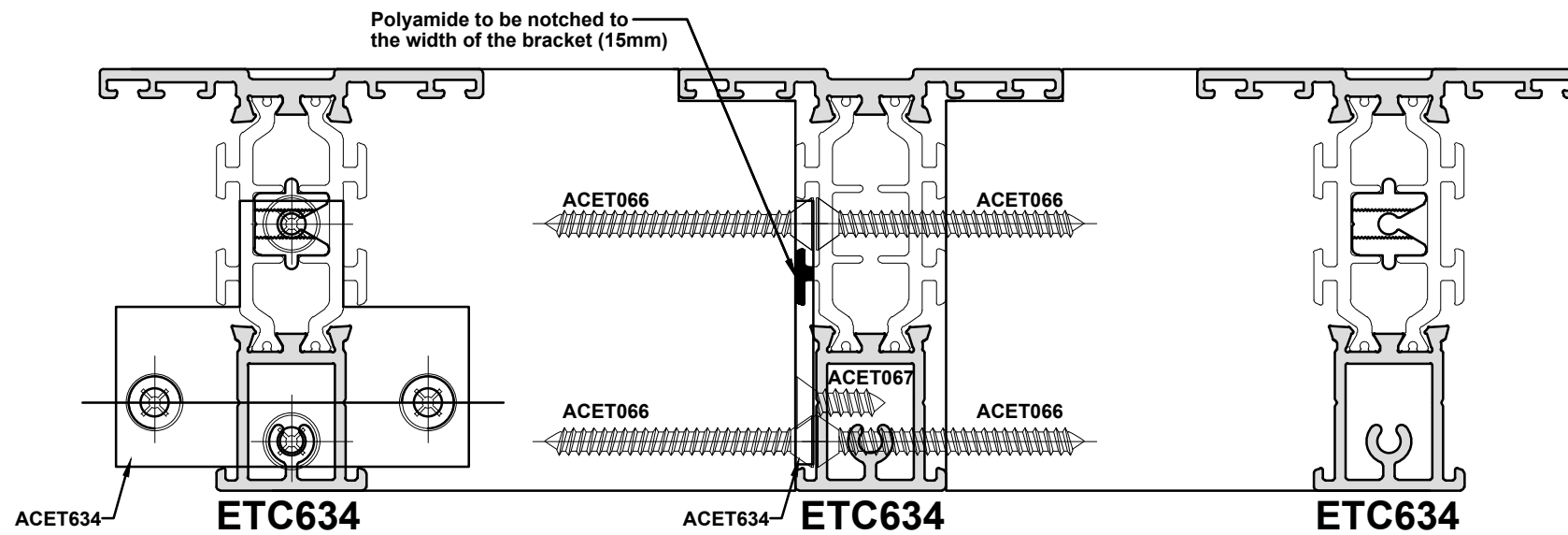
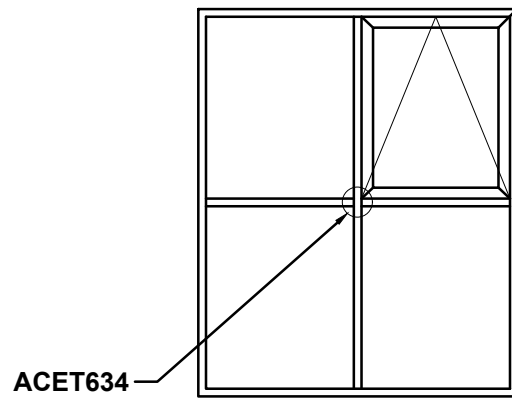
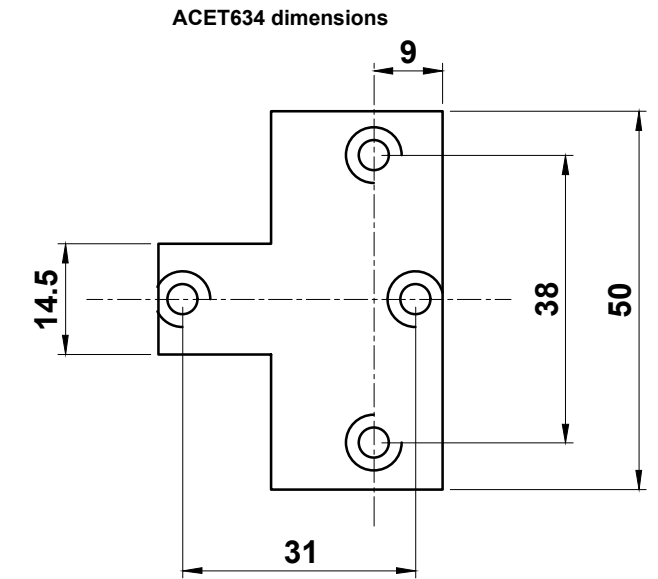
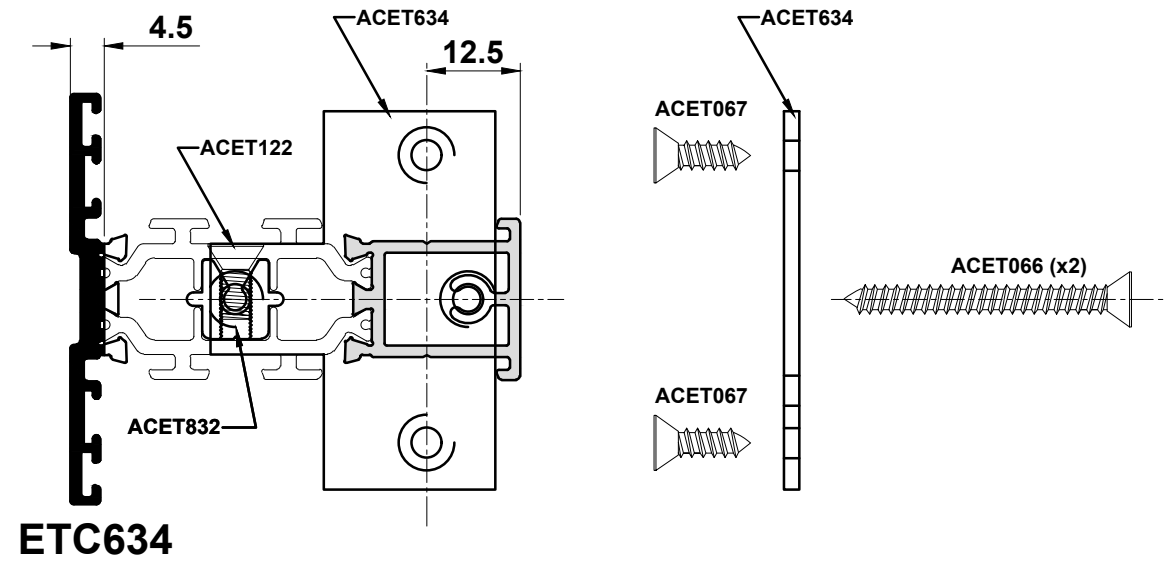
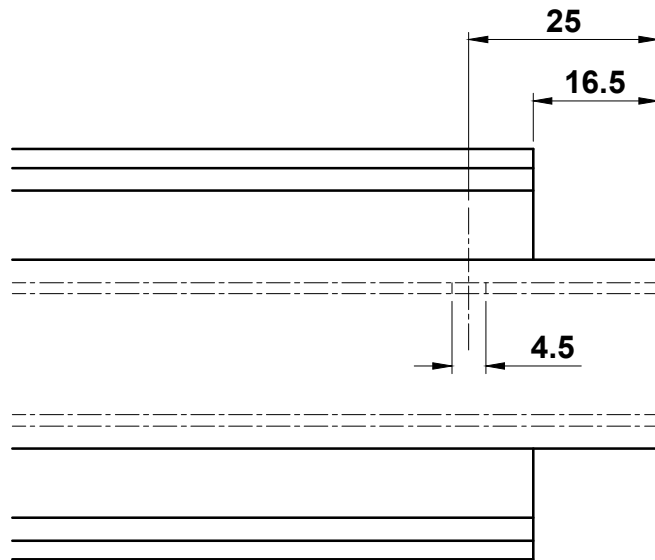
Transom/Mullion Preparation



Note:
End mill cutters can be ordered through Smart Systems Ltd.
Please contact the Technical Department for an order form.
Standard delivery is 2-3 weeks approx.

Do Not Scale From This Drawing

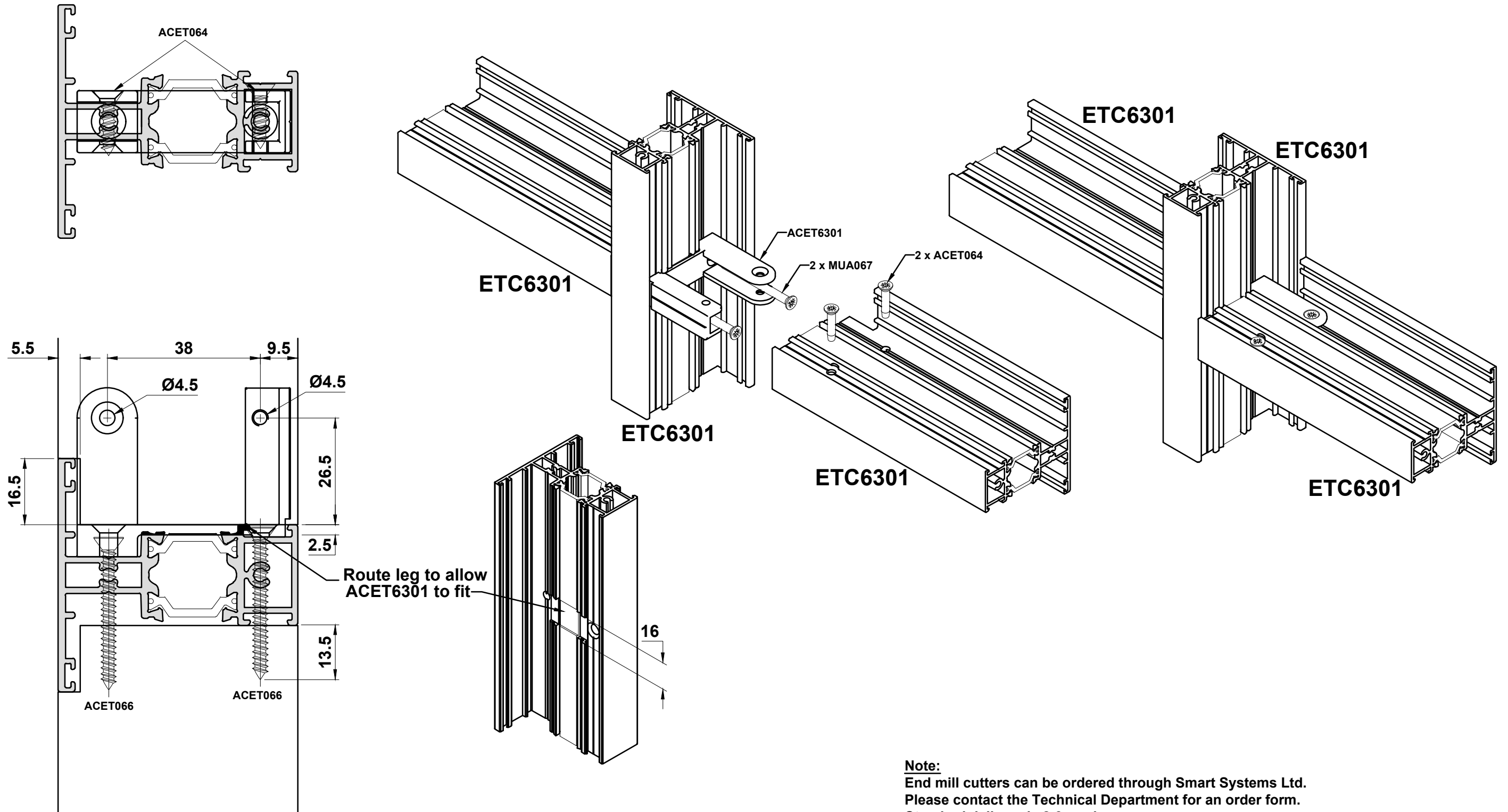
Transom/Mullion Preparation



Note:
End mill cutters can be ordered through Smart Systems Ltd.
Please contact the Technical Department for an order form.
Standard delivery is 2-3 weeks approx.

Do Not Scale From This Drawing

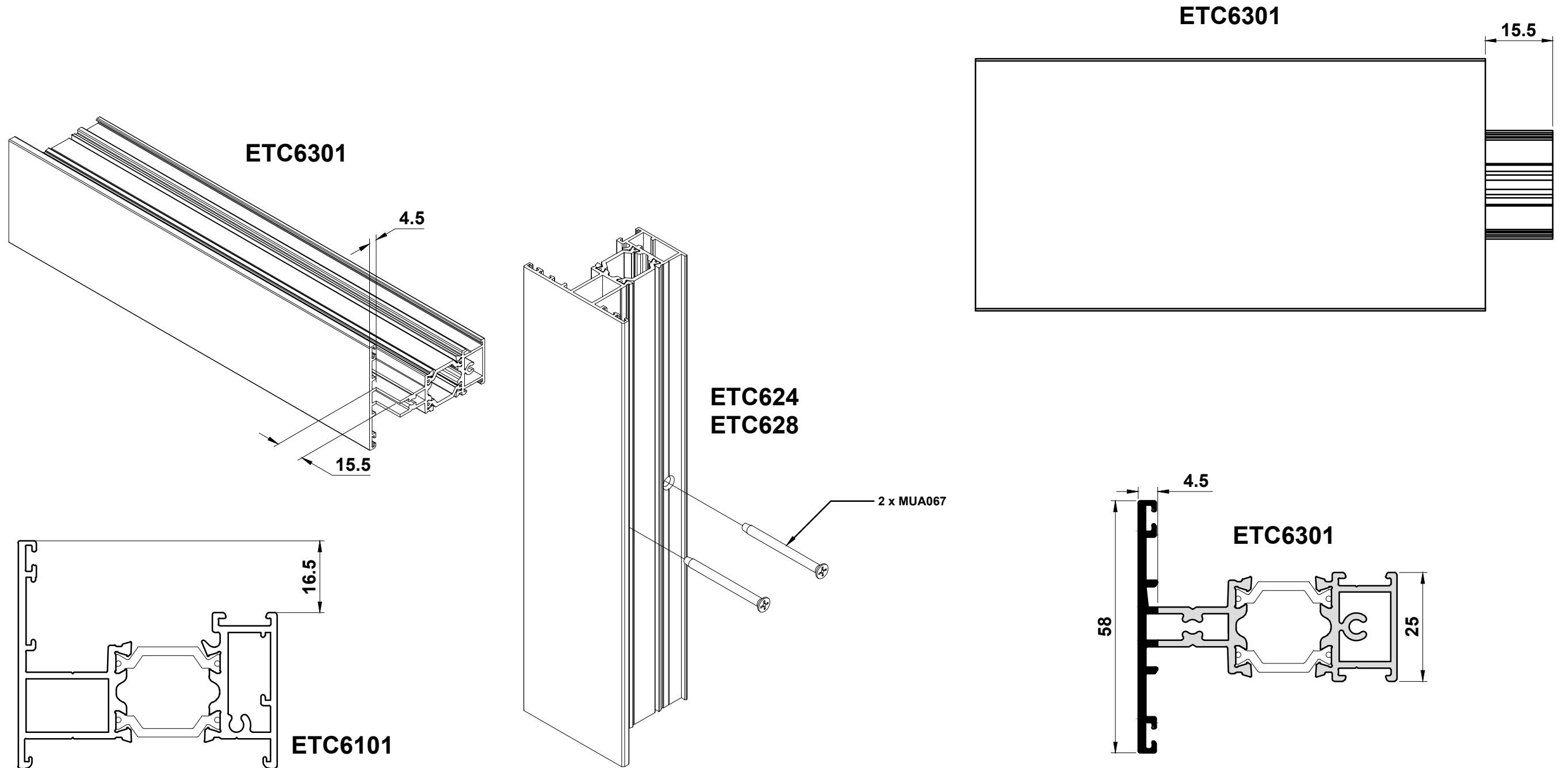
ETC6301 Transom/Mullion Preparation



Note:
End mill cutters can be ordered through Smart Systems Ltd.
Please contact the Technical Department for an order form.
Standard delivery is 2-3 weeks approx.

Do Not Scale From This Drawing

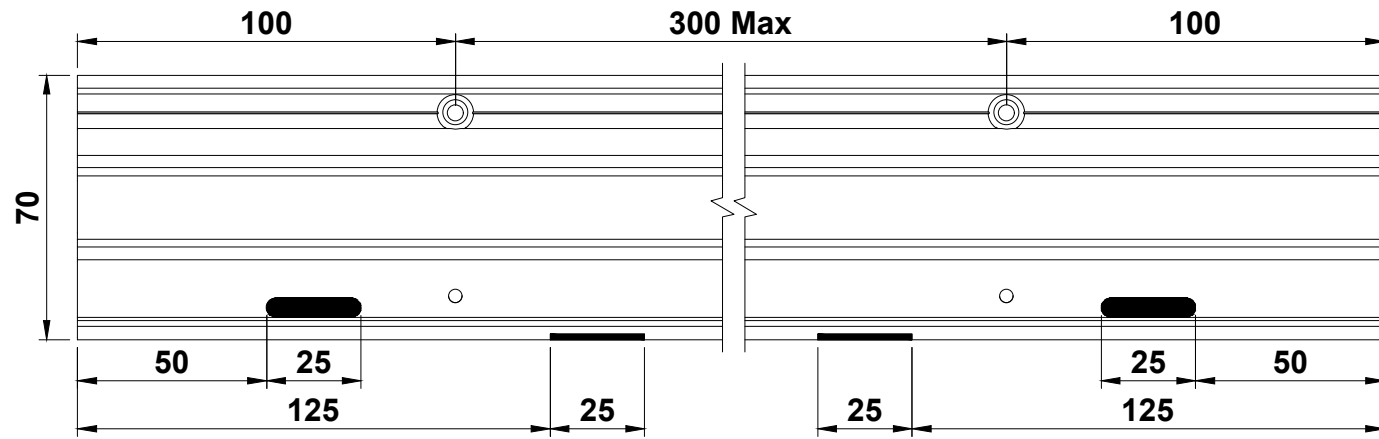
ETC6301 Dummy Transom for ETC624/ETC628 Preparation



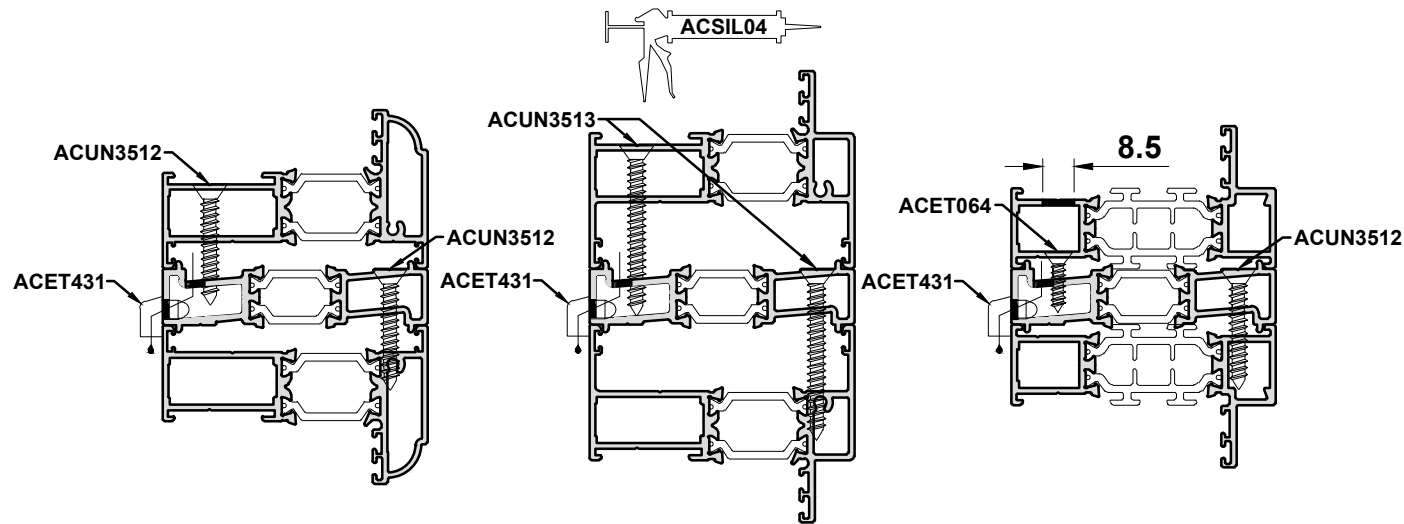
Note:
End mill cutters can be ordered through Smart Systems Ltd.
Please contact the Technical Department for an order form.
Standard delivery is 2-3 weeks approx.

Do Not Scale From This Drawing

UN3000 Horizontal Coupler Detail



Important Note: Seal all joints to UN3000 using ACSIL04.

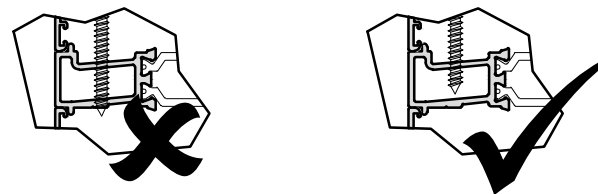


ETC611

**ETC614
ETC618
ETC619**

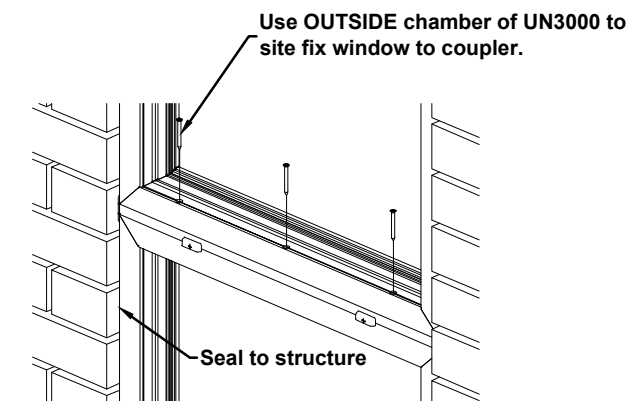
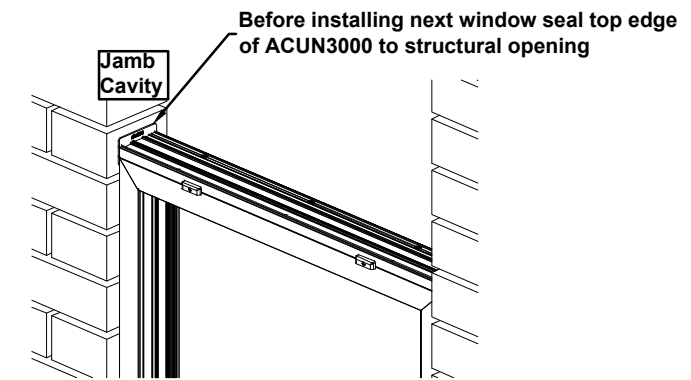
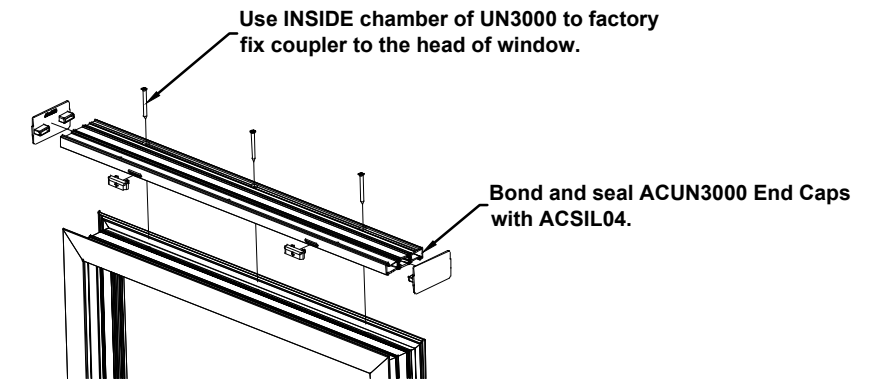
ETC615

Important Note: Do not screw through drainage channel.



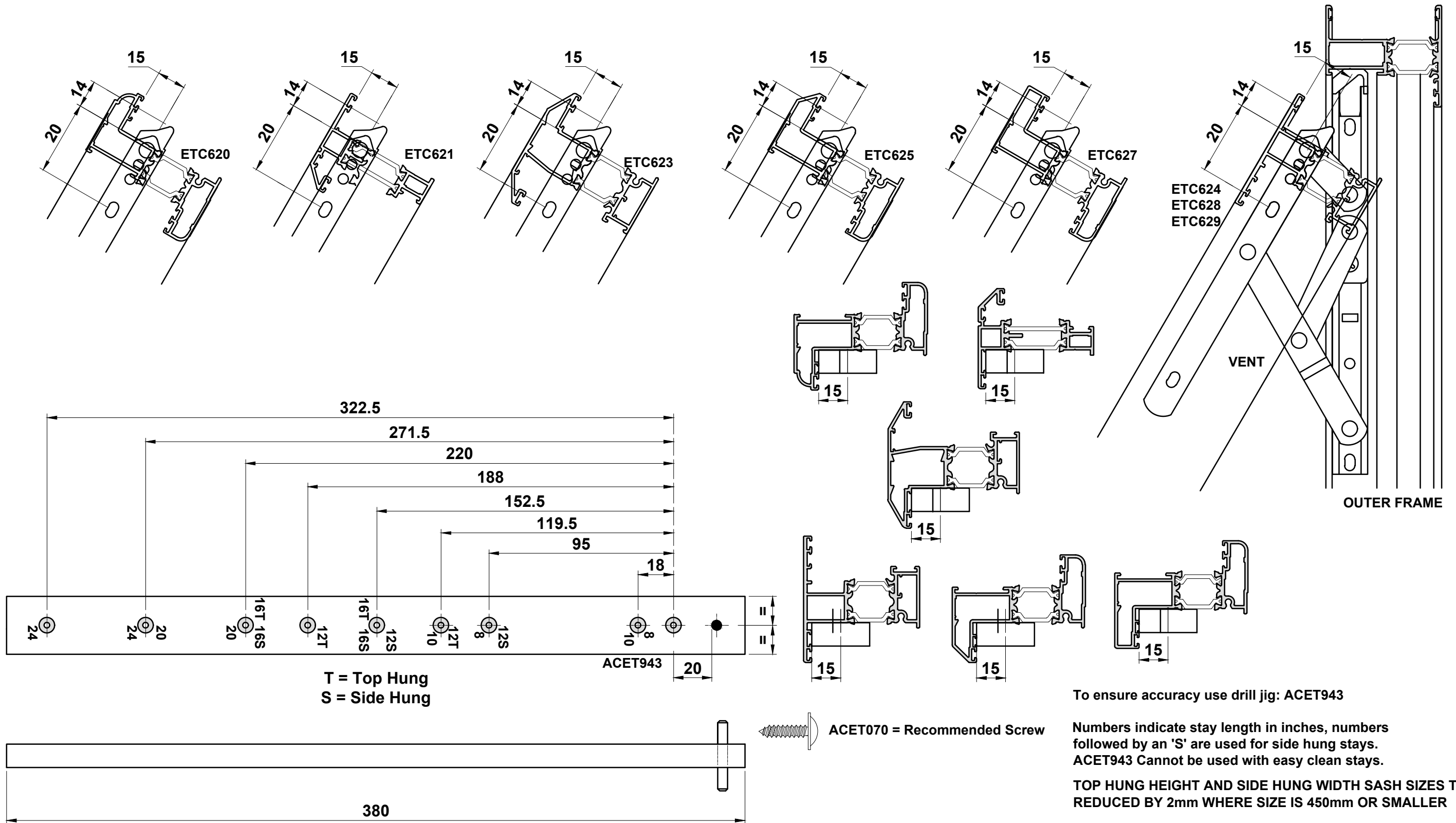
Zone Drainage of Jamb Cavity

CWCT Built up wall guidance recommends drainage of Jamb Cavity



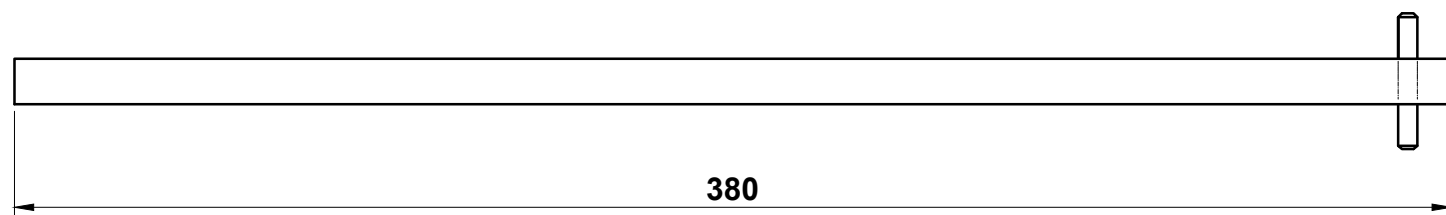
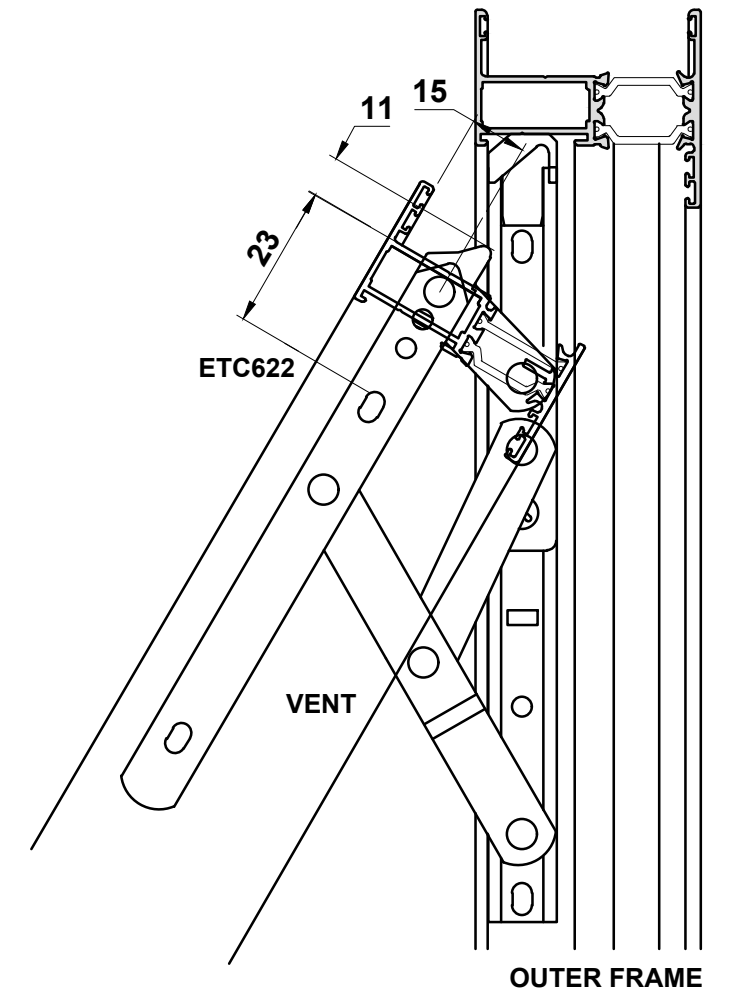
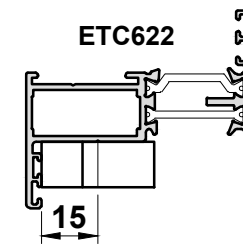
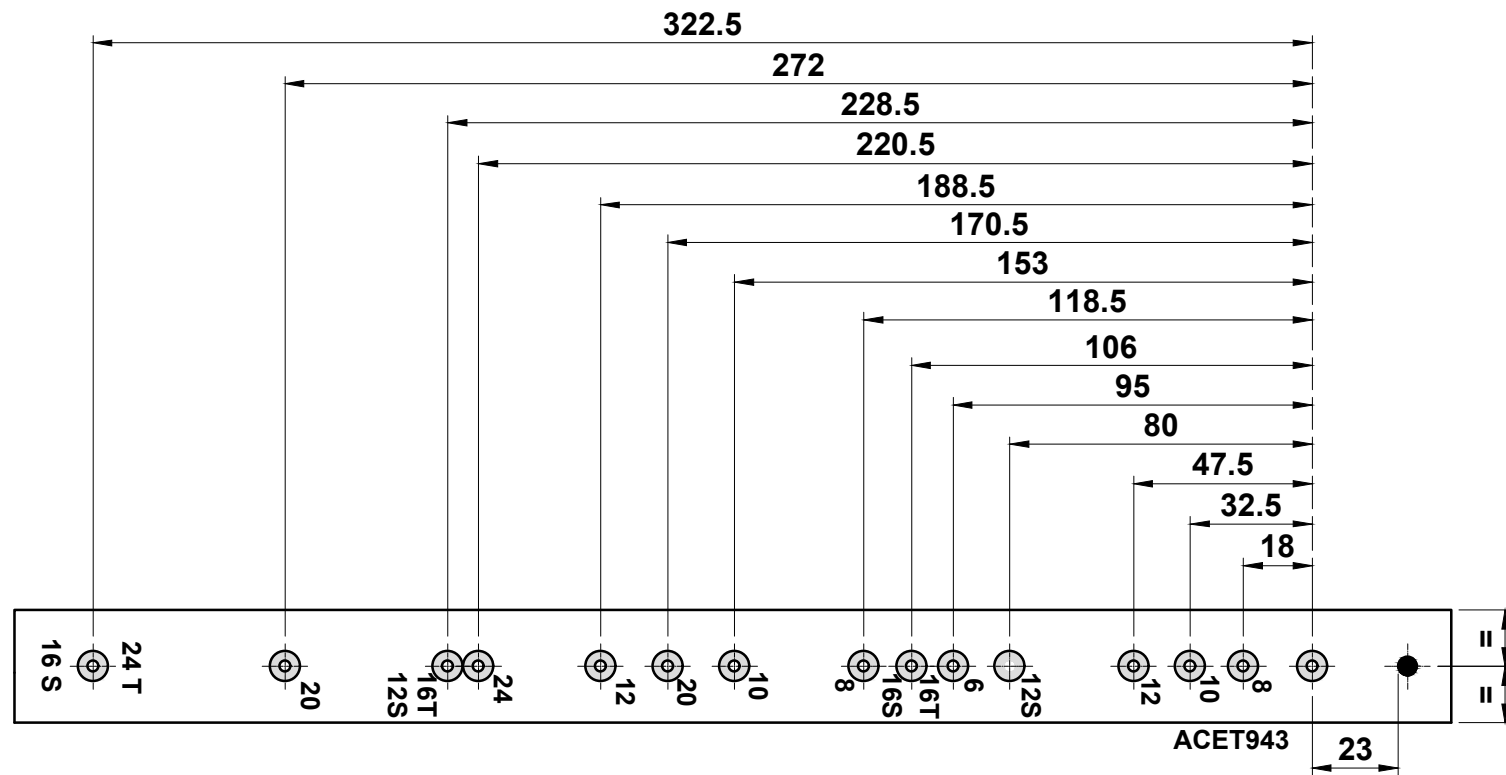
Do Not Scale From This Drawing

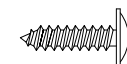
16mm Stack Height Friction Hinge Details



Do Not Scale From This Drawing

13mm Stack Height Friction Hinge Details



 ACET070 = Recommended Screw

To ensure accuracy use drill jig:
Top Hung Vents ACET944

Numbers indicate stay length in inches, numbers followed by an 'S' are used for side hung stays.

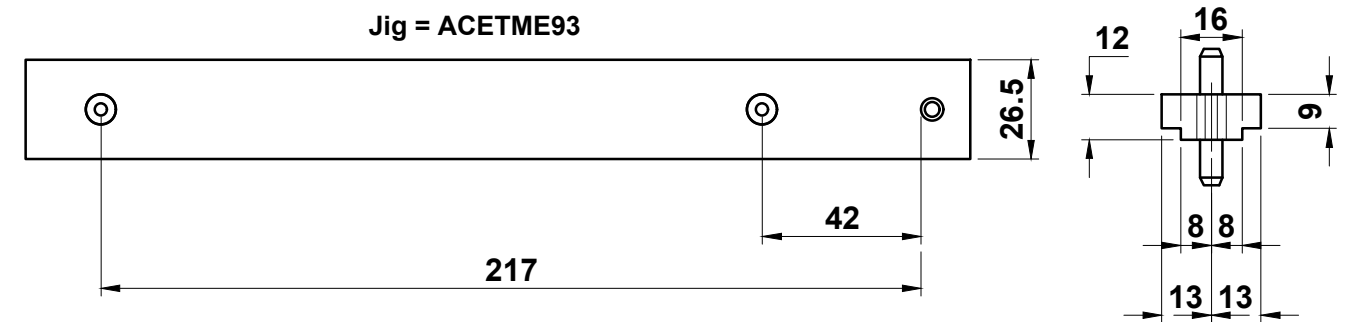
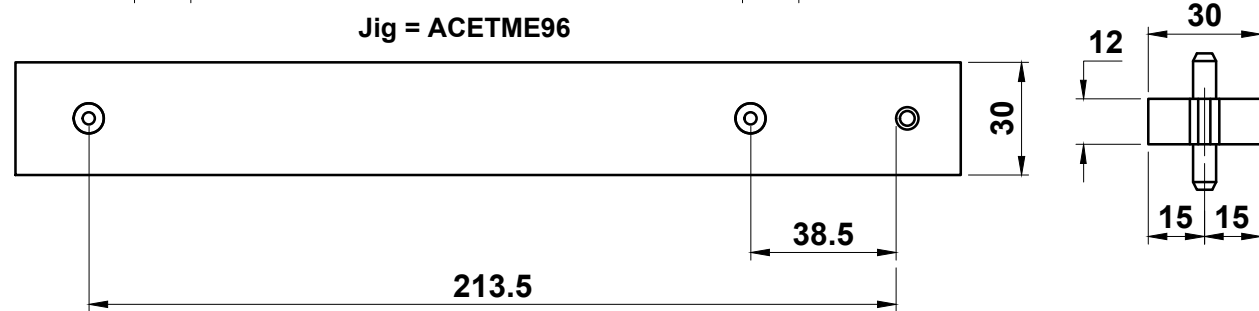
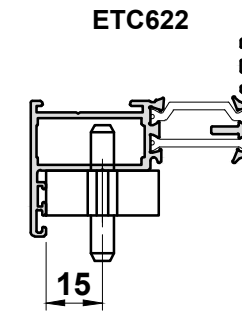
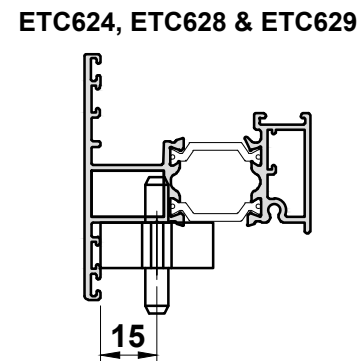
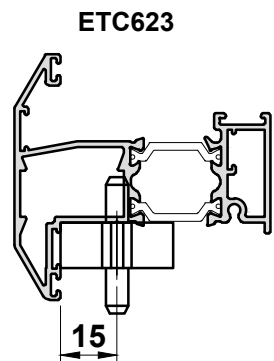
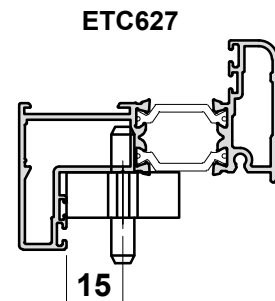
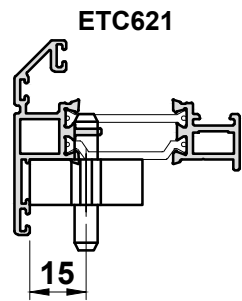
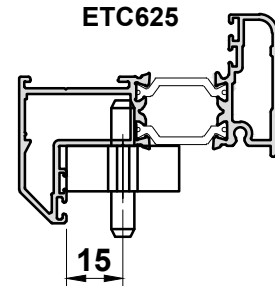
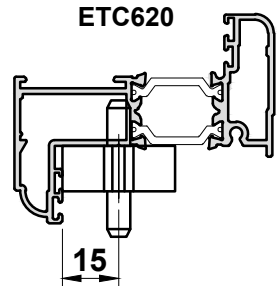
TOP HUNG HEIGHT AND SIDE HUNG WIDTH SASH SIZES TO BE REDUCED BY 2mm WHERE SIZE IS 450mm OR SMALLER

Do Not Scale From This Drawing

Easy Clean Friction Hinge Details

16mm Stack

13mm Stack



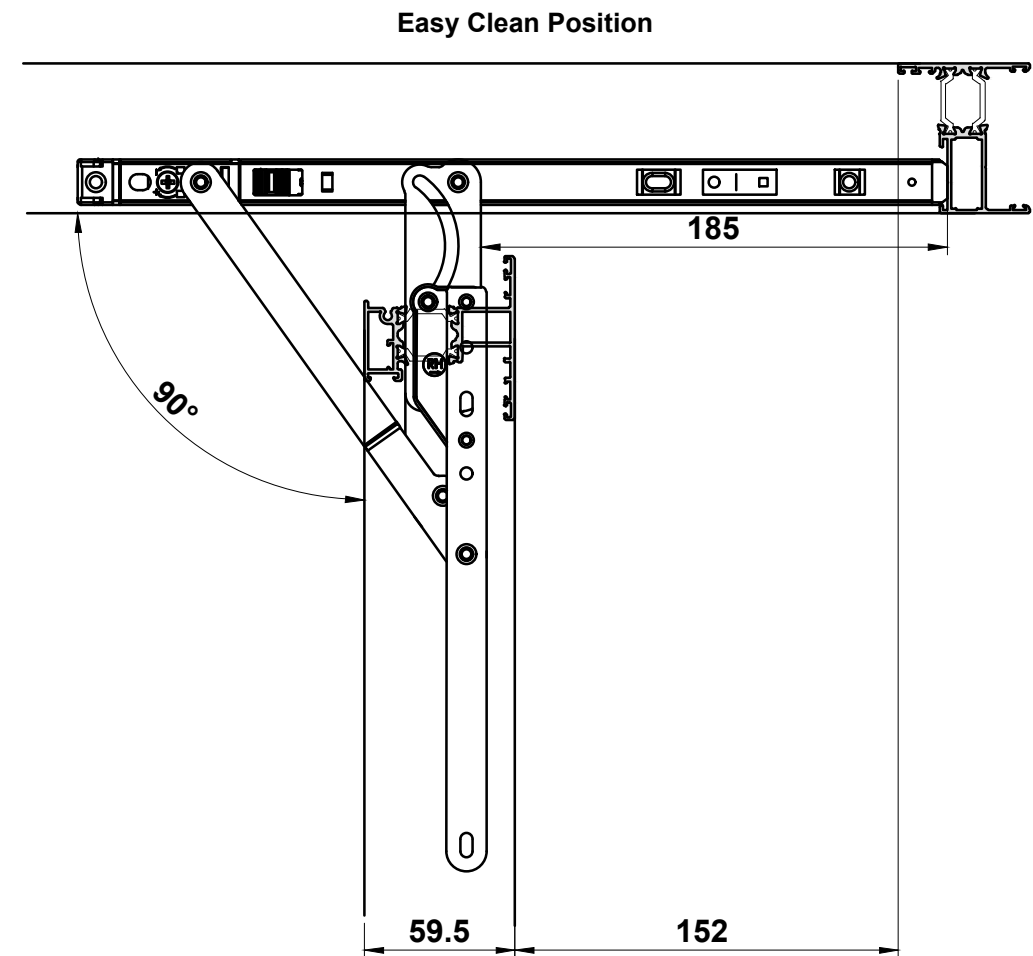
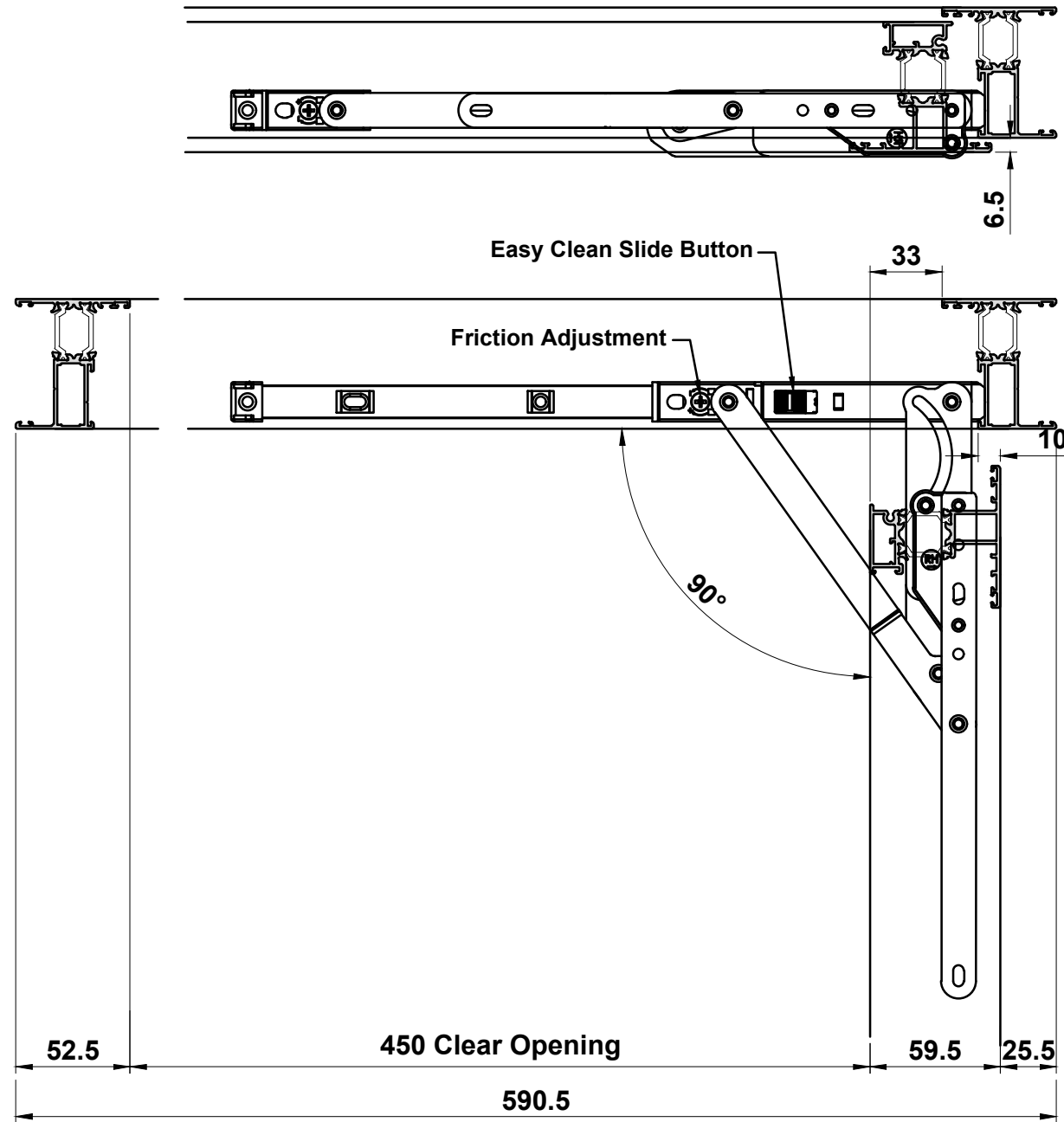
Note: ACETME96 Jig is not compatible with ETC622.
Use ACETME93 to mark the hole positions in the vee groove.

**Vent Sizes 450mm or Smaller
to be Reduced by 2mm**

Do Not Scale From This Drawing

Easy Clean Friction Hinge Details

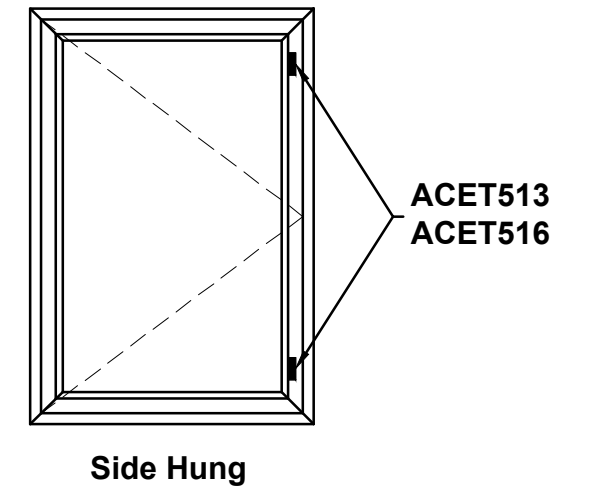
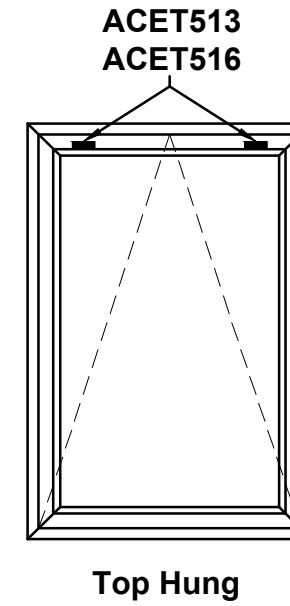
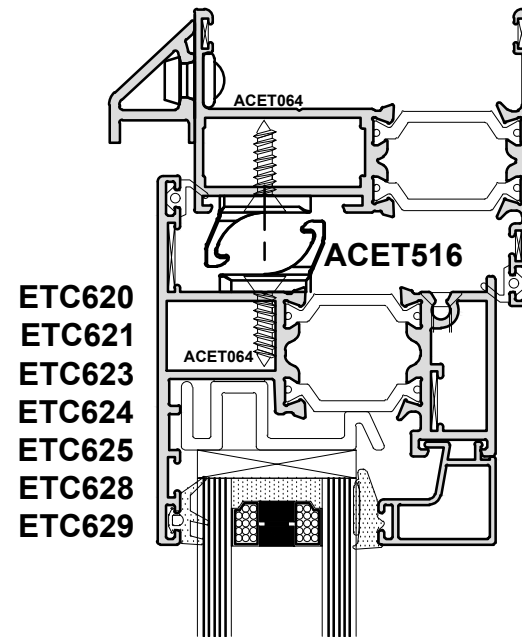
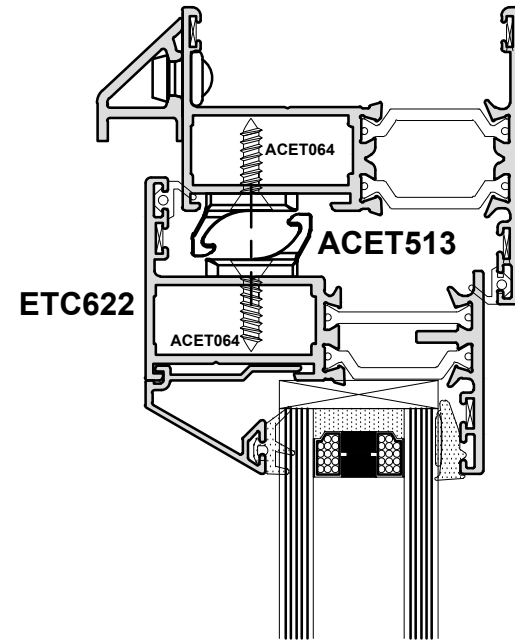
Example Opening Detail



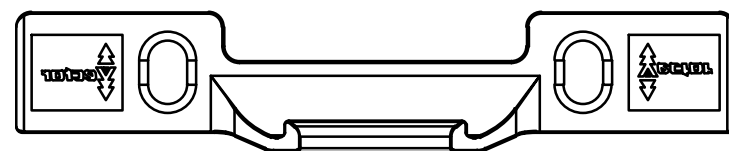
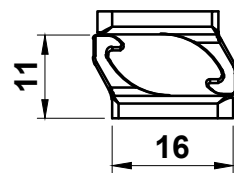
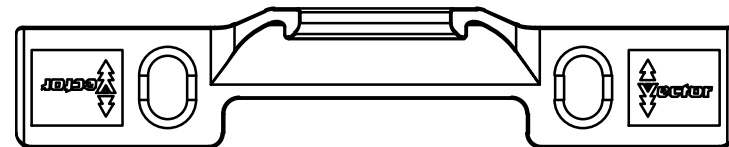
For further information regarding clear openings, please see
the Smart Systems' White Paper Document B

Do Not Scale From This Drawing

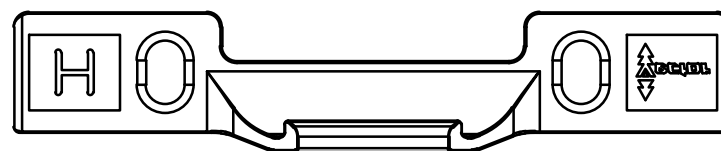
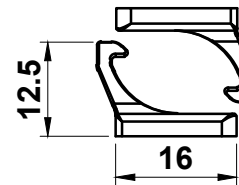
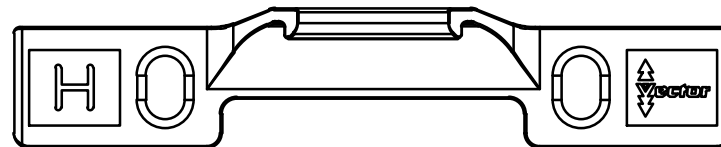
ACET513 & ACET516 Fitting Guide



ACET513
Scale 1:1



ACET516
Scale 1:1

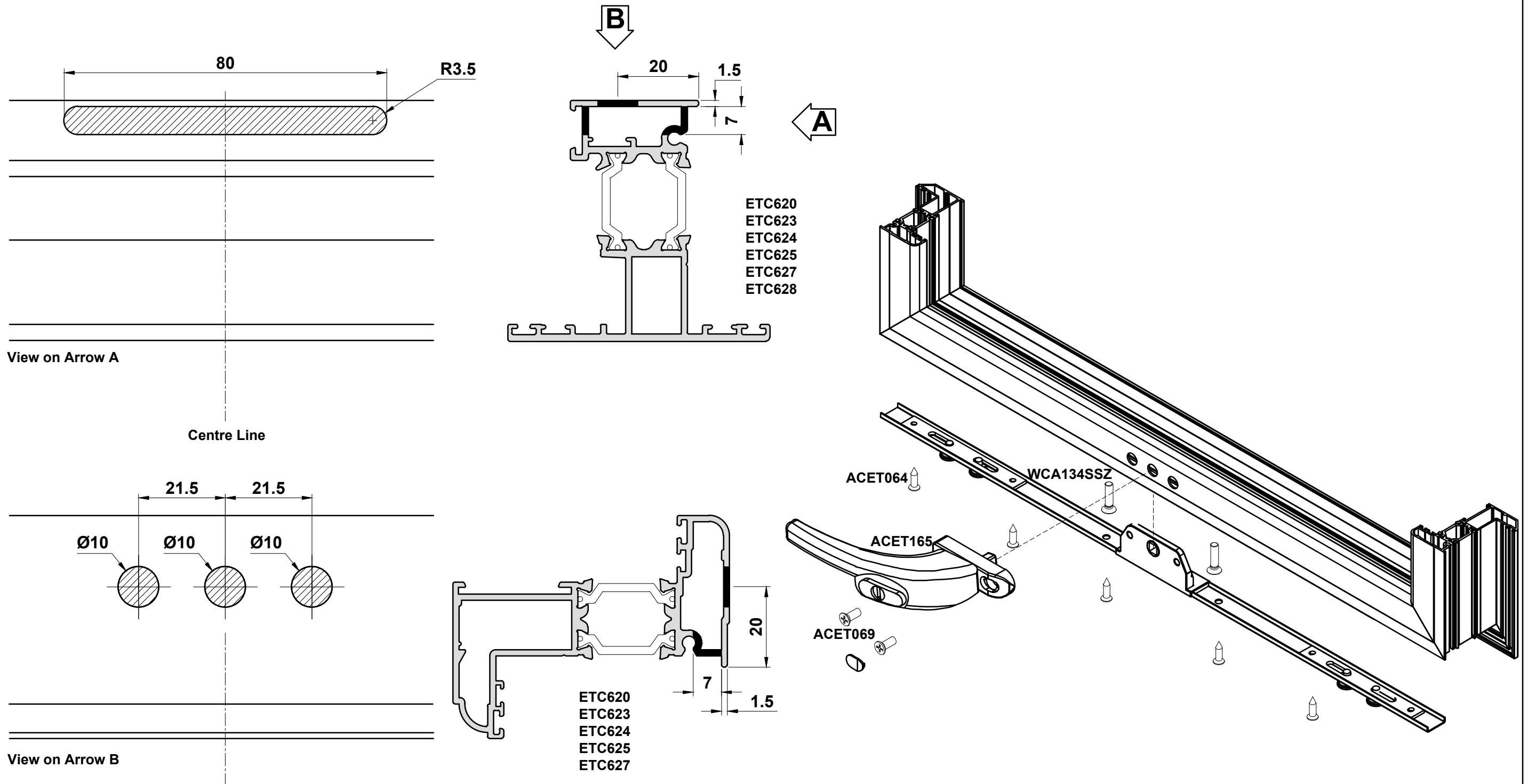


Please Note:

- 2 pairs per opening vent to be fitted to hinged side of window
- Each pair must be fitted with the hook centre within 100mm of each hinge

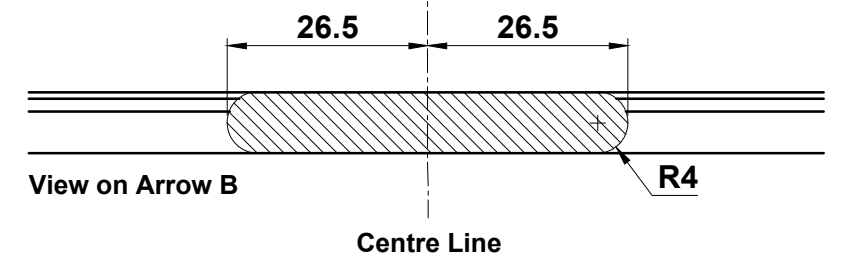
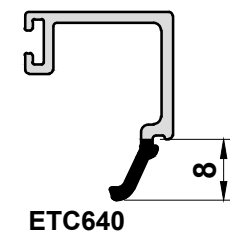
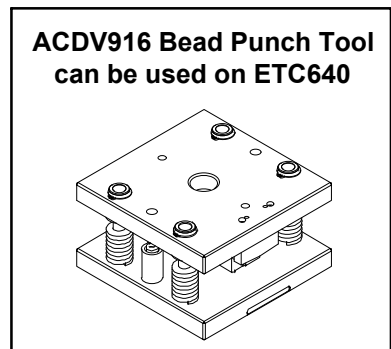
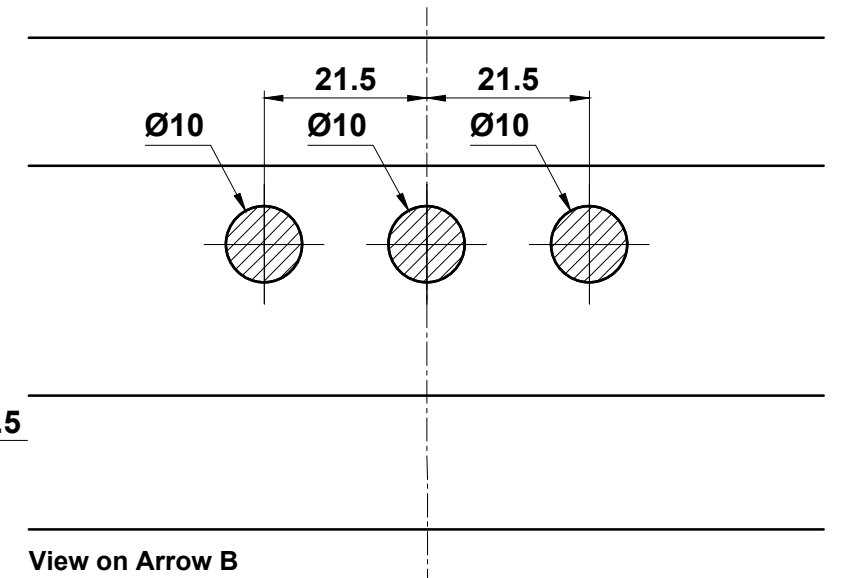
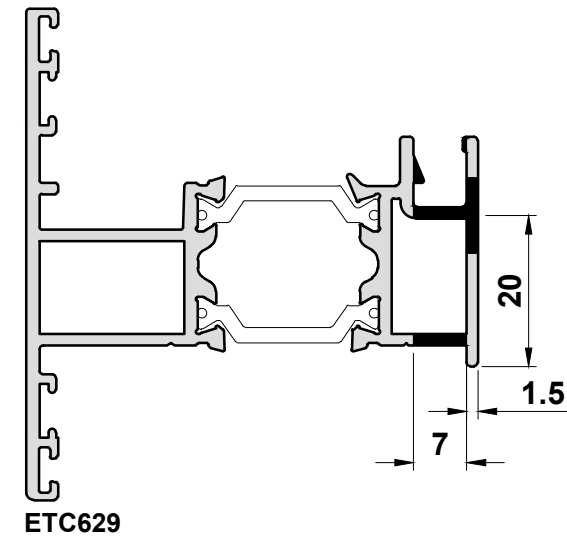
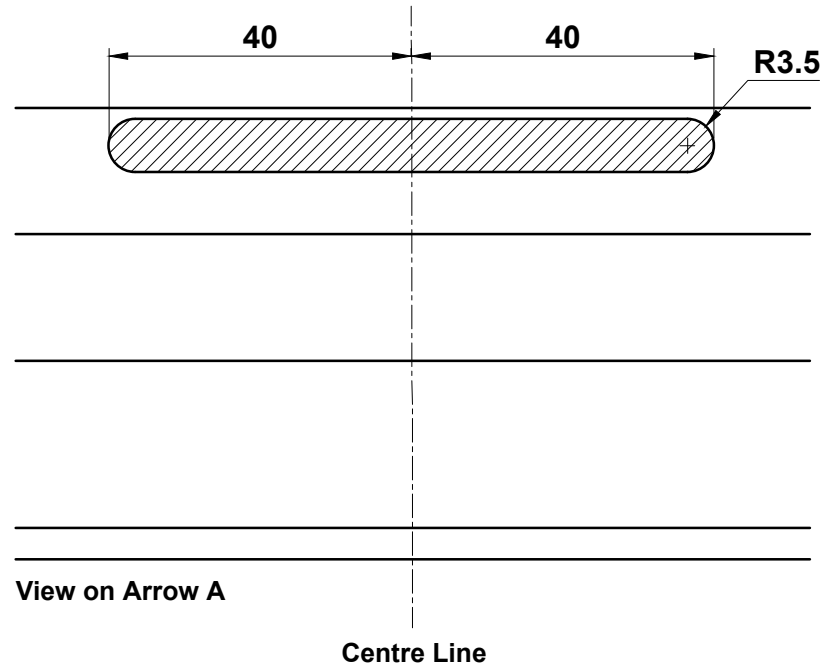
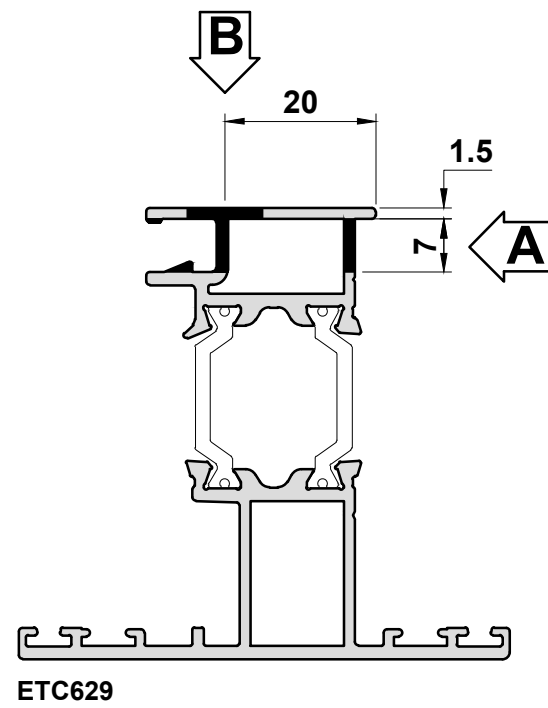
Do Not Scale From This Drawing

Multi-Point Locking Preparation



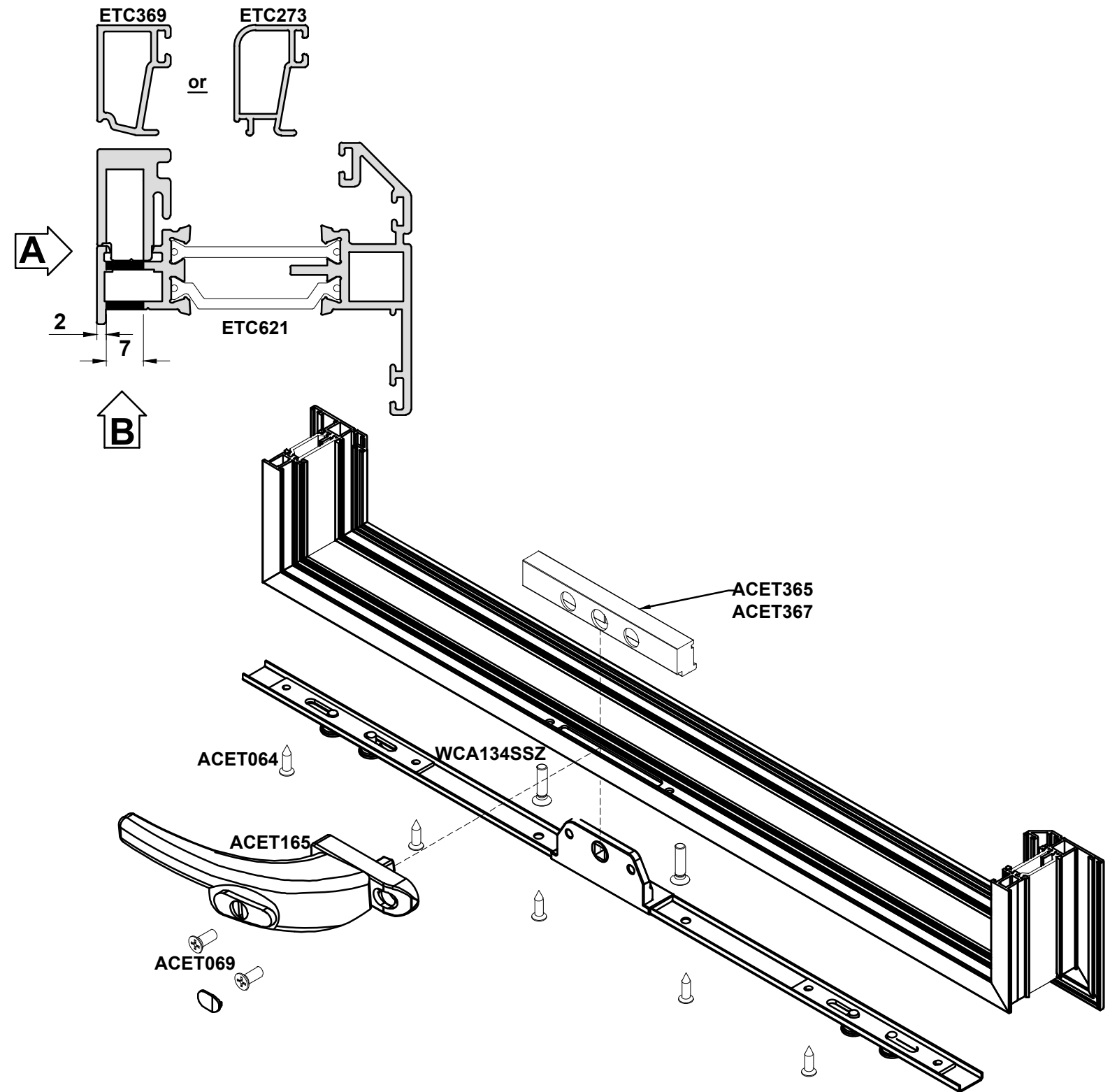
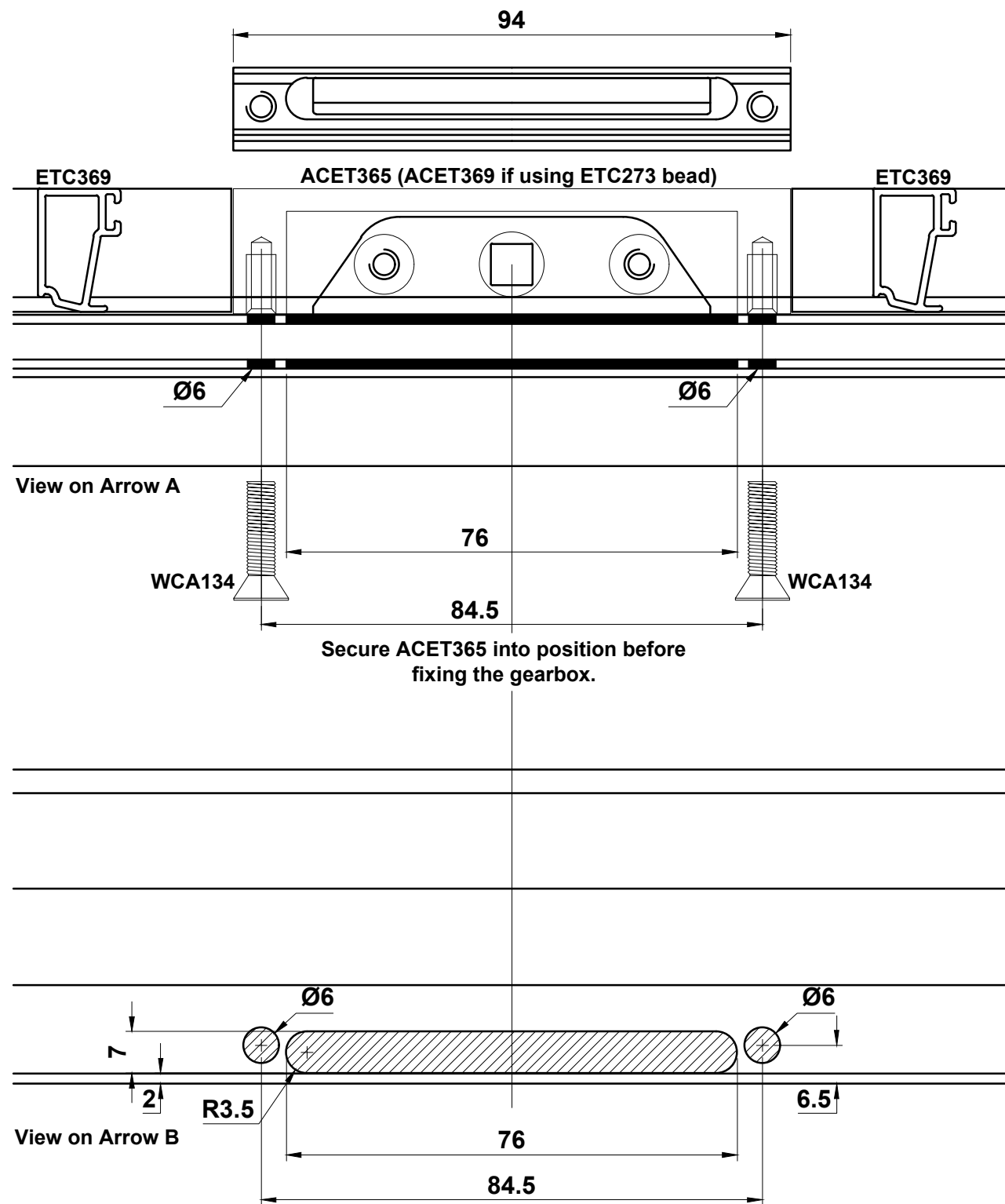
Do Not Scale From This Drawing

Multi-Point Locking Preparation



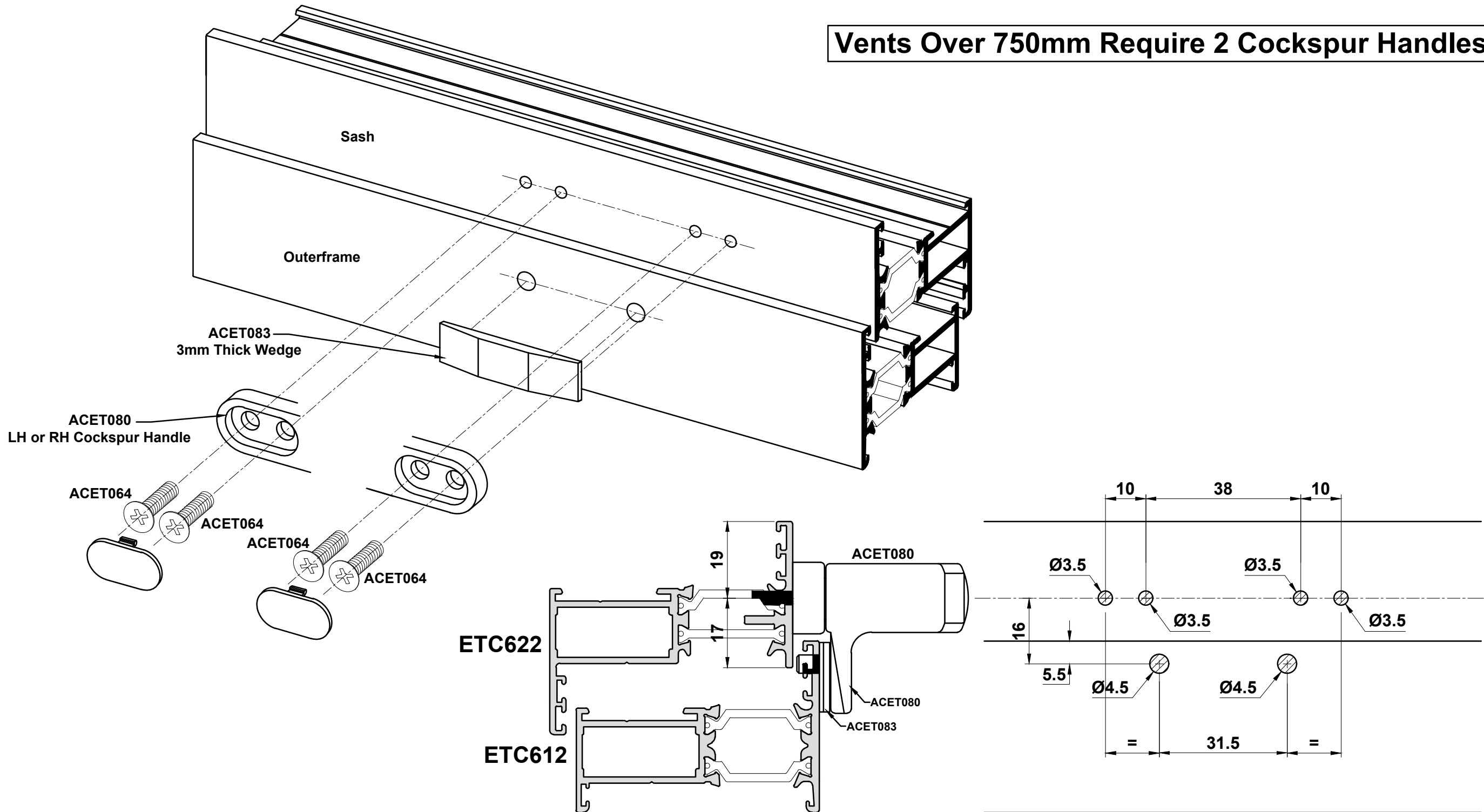
Do Not Scale From This Drawing

Multi-Point Locking Preparation



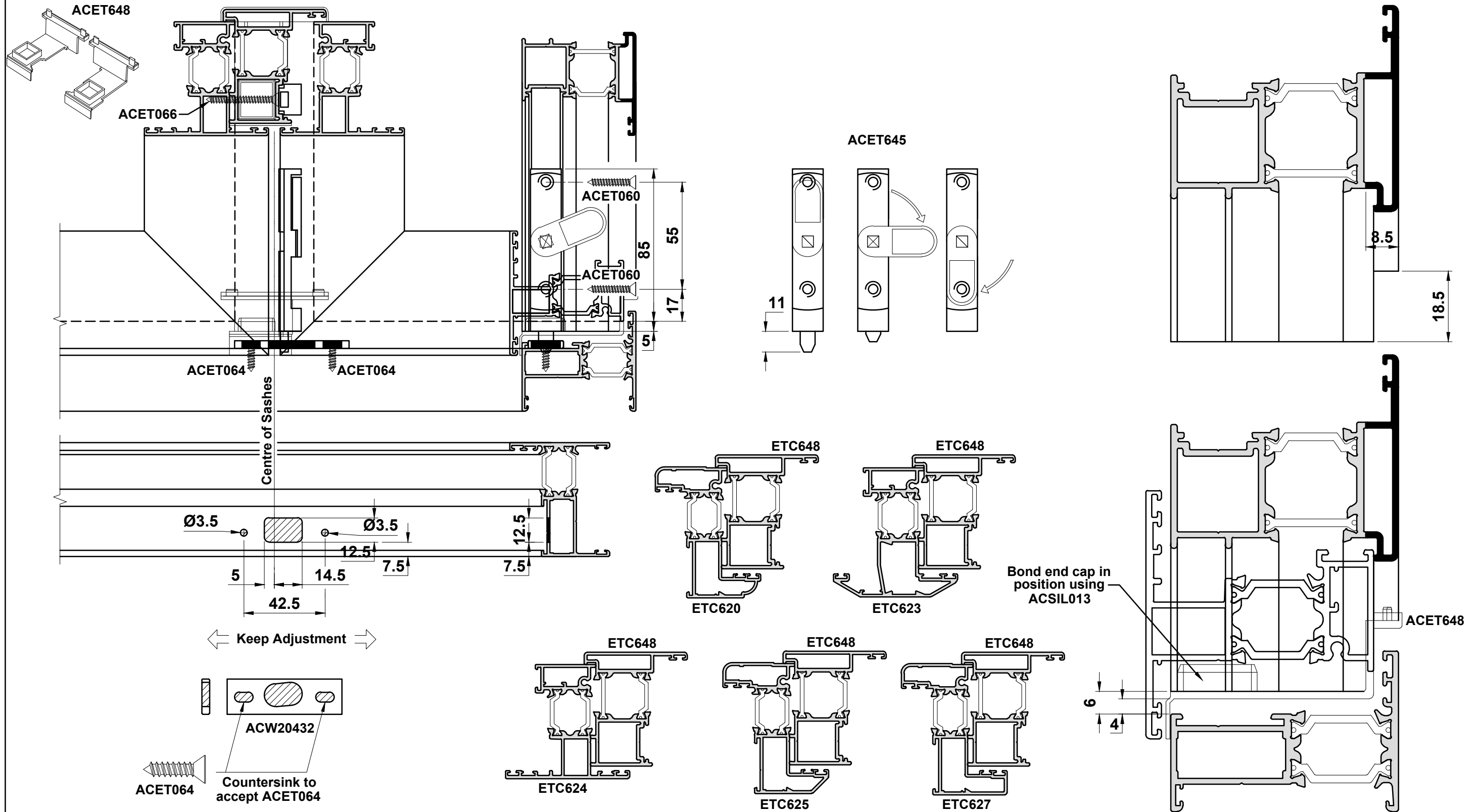
Cockspur Locking Preparation

Vents Over 750mm Require 2 Cockspur Handles

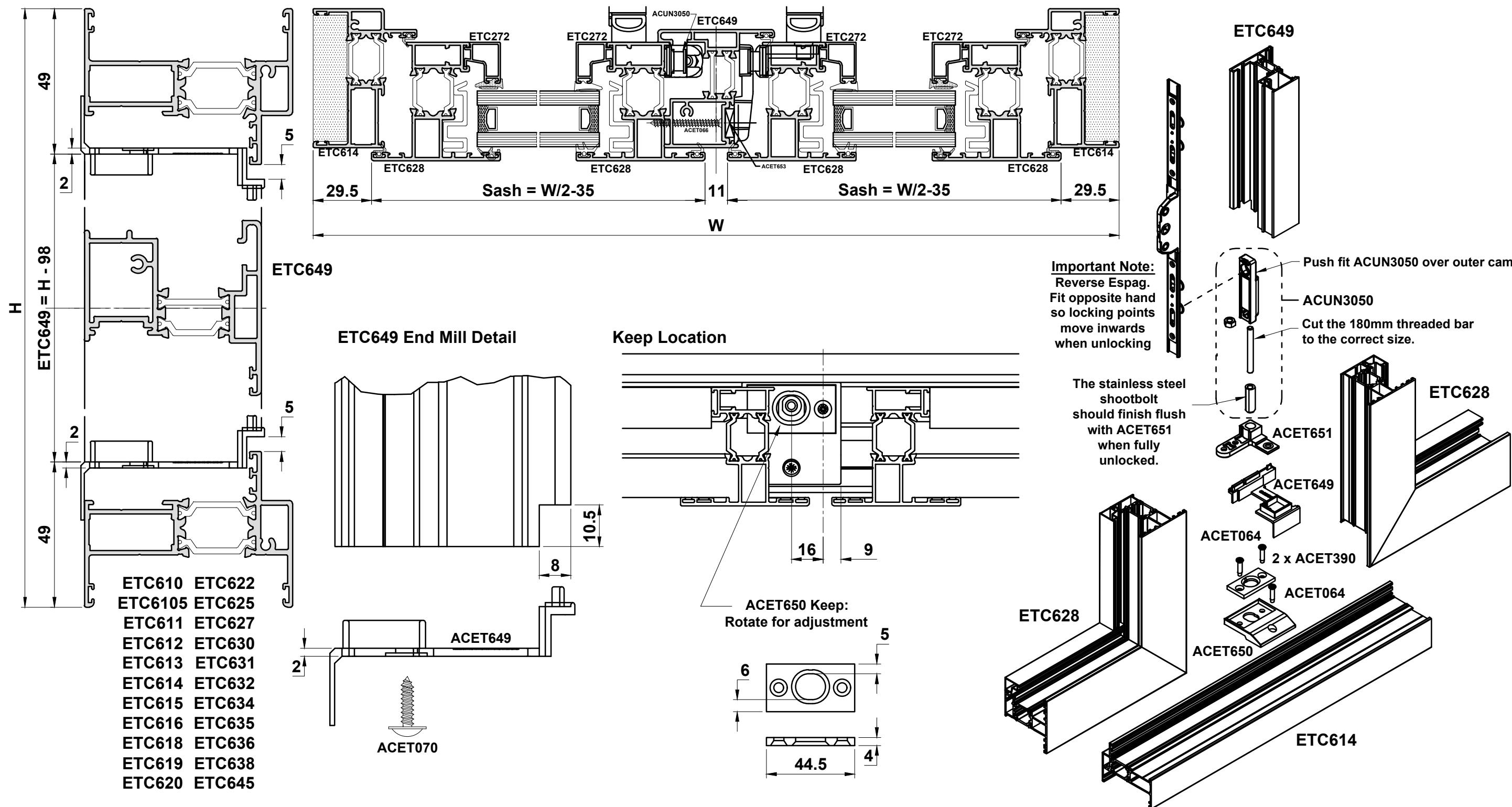


Do Not Scale From This Drawing

French Casement Detail



French Casement Detail

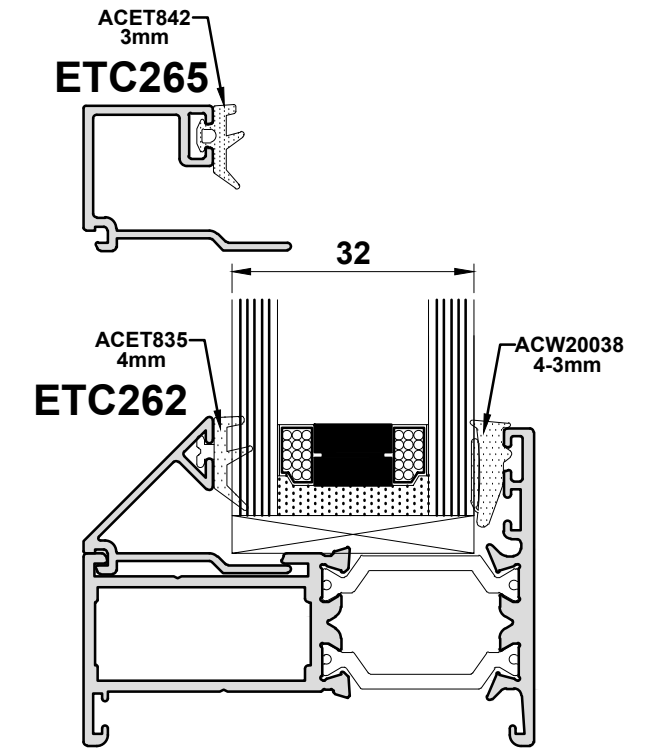
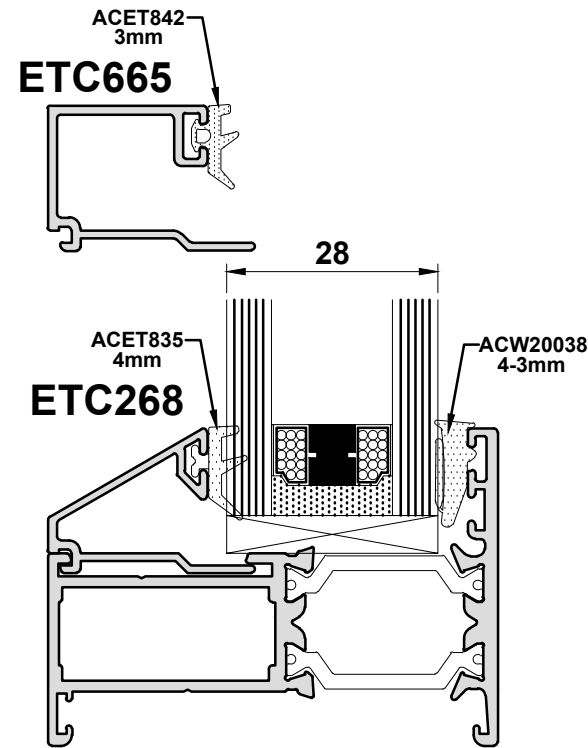
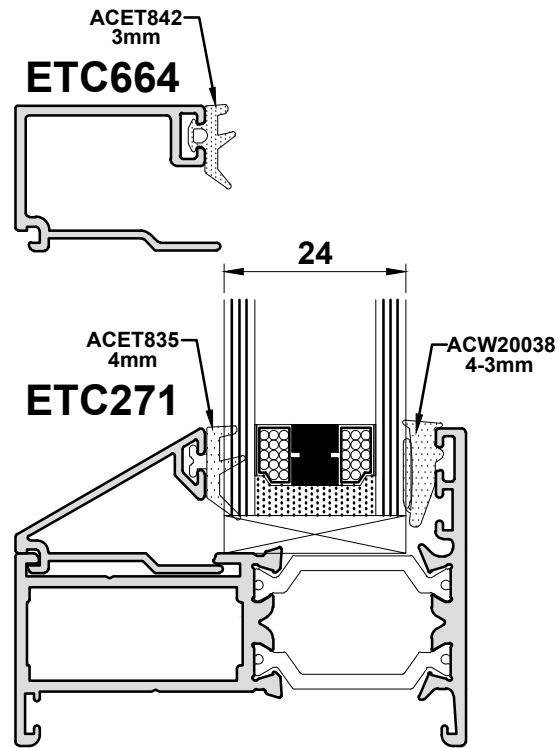


Do Not Scale From This Drawing

Glazing Chart

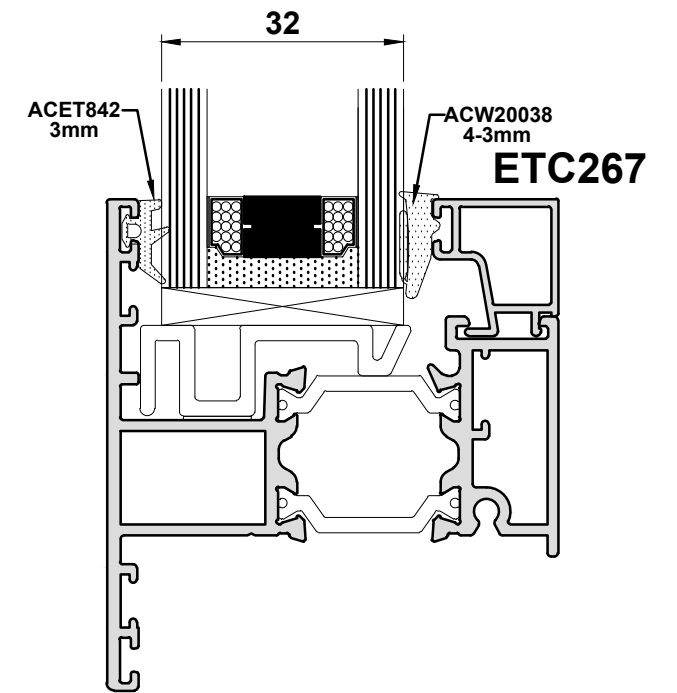
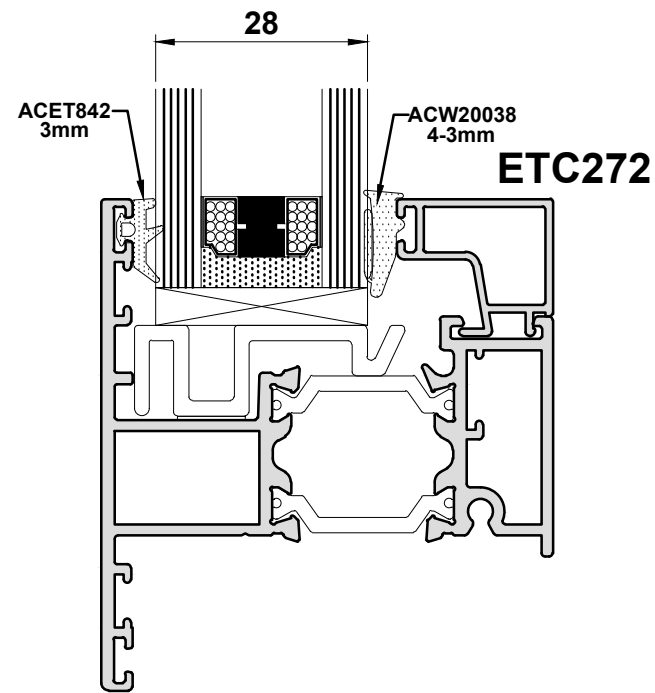
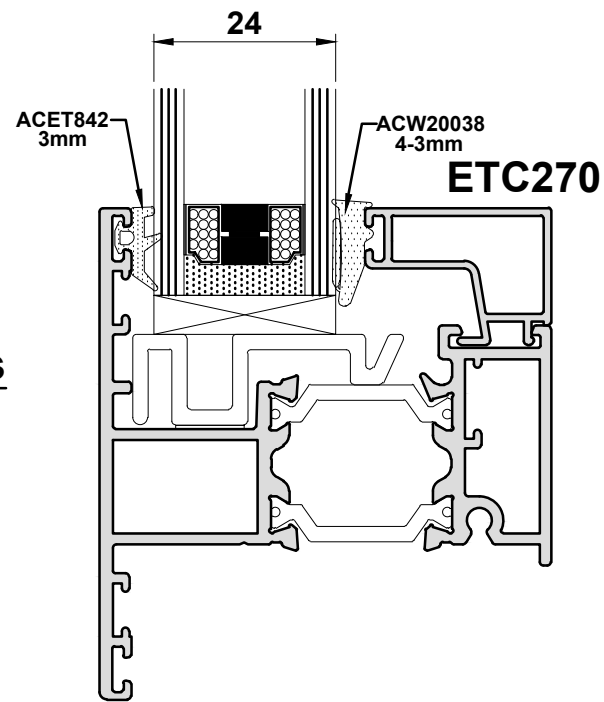
Externally Beaded Sections

- ETC610 ETC620 ETC630
- ETC6105 ETC622 ETC631
- ETC611 ETC625 ETC632
- ETC612 ETC627 ETC634
- ETC613 ETC635
- ETC614 ETC636
- ETC615 ETC638
- ETC616 ETC645
- ETC618
- ETC619

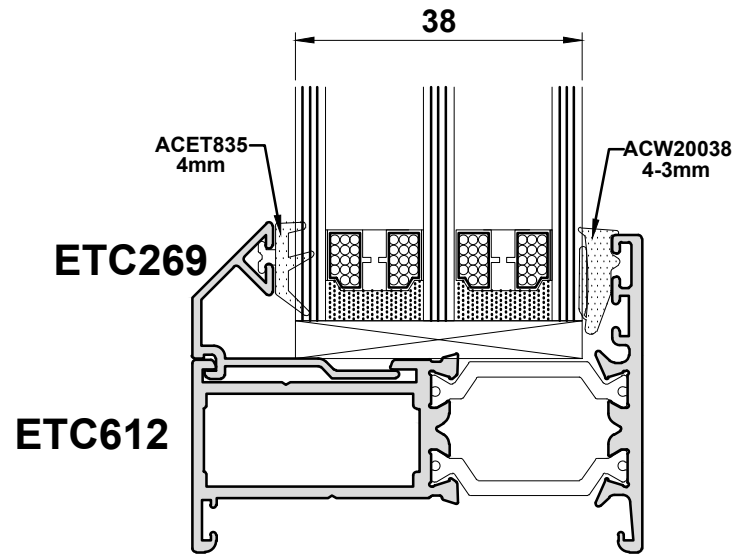


Internally Beaded Sections

- ETC6101
- ETC6301
- ETC623
- ETC624
- ETC628
- ETC647

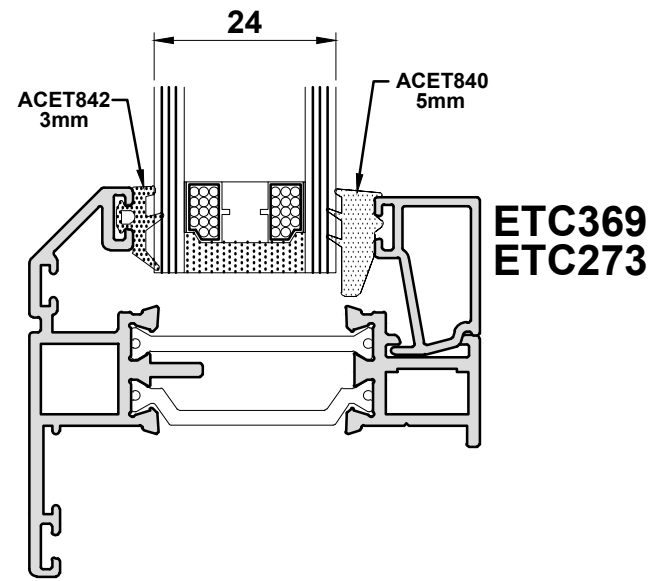


Glazing Chart



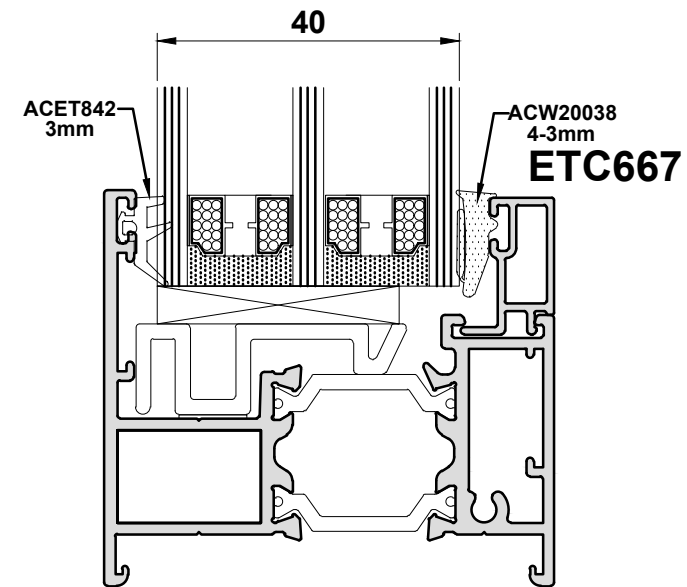
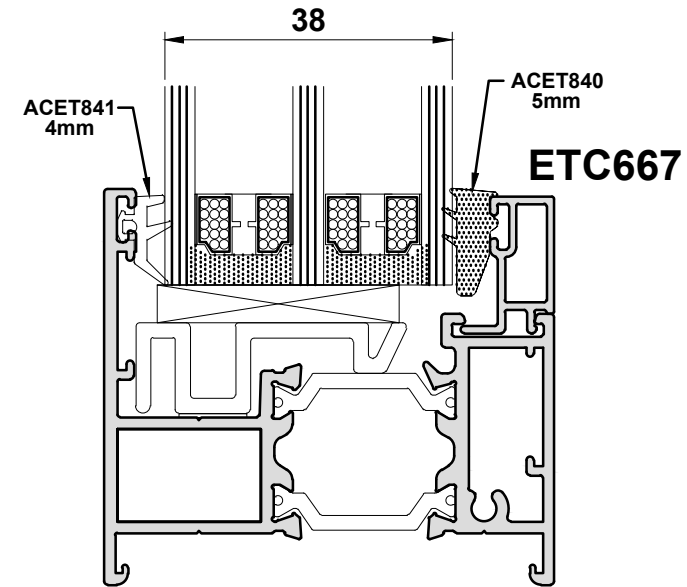
Externally Beaded Sections

- ETC610 ETC620 ETC630
- ETC6105 ETC622 ETC631
- ETC611 ETC625 ETC632
- ETC612 ETC627 ETC634
- ETC613 ETC635
- ETC614 ETC636
- ETC615 ETC638
- ETC616 ETC645
- ETC618
- ETC619



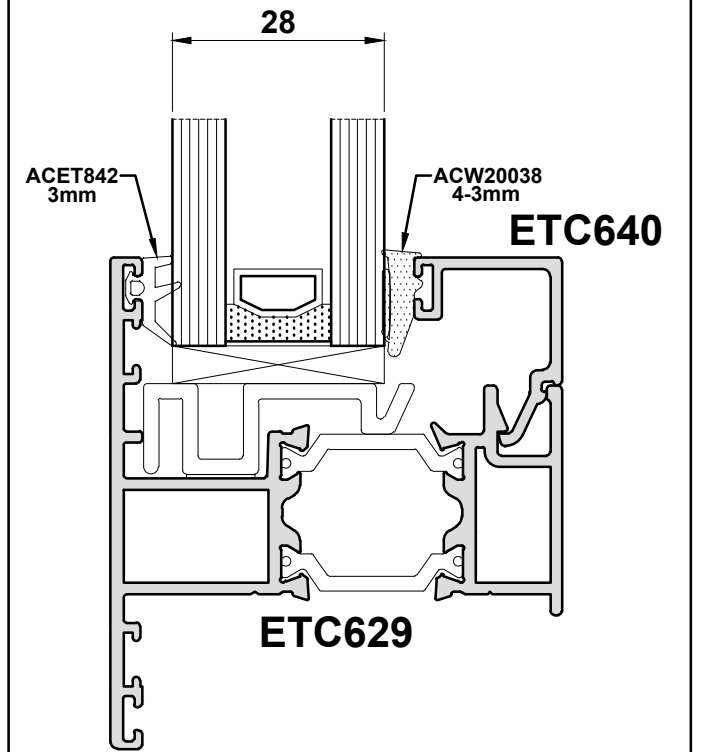
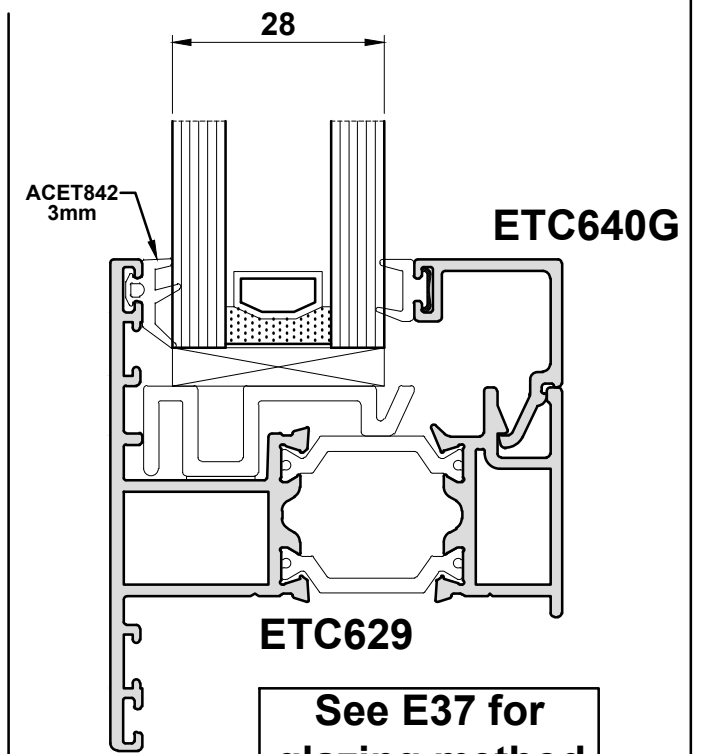
Internally Beaded Section

ETC621
24mm ONLY

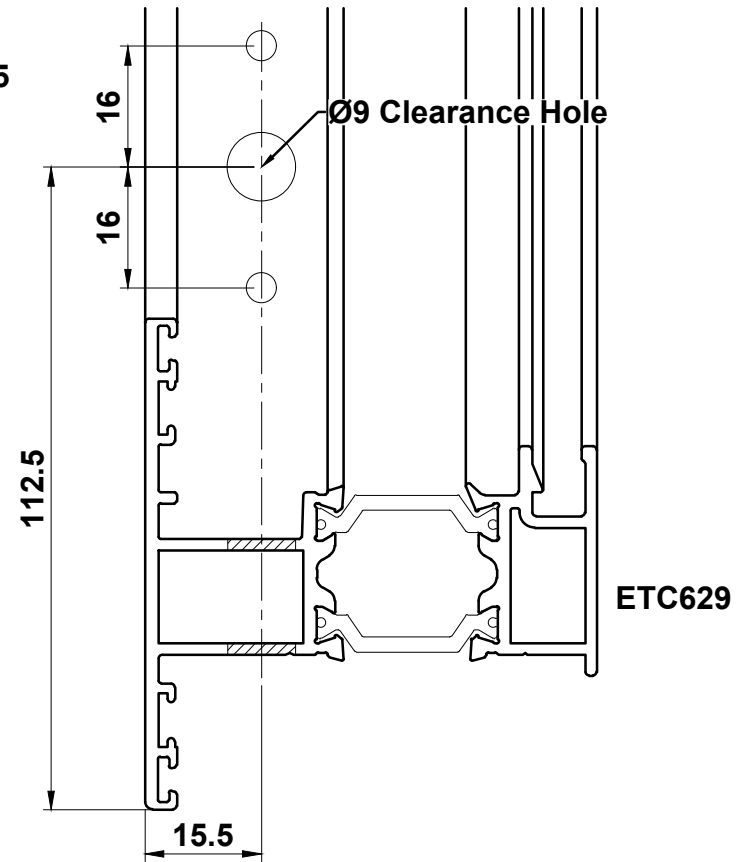
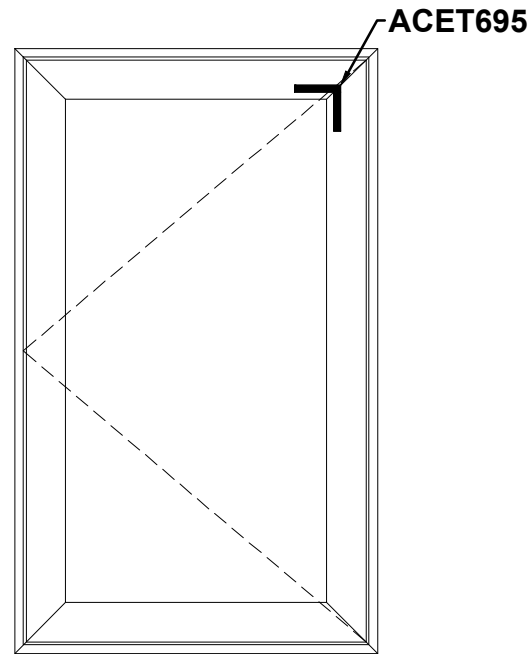
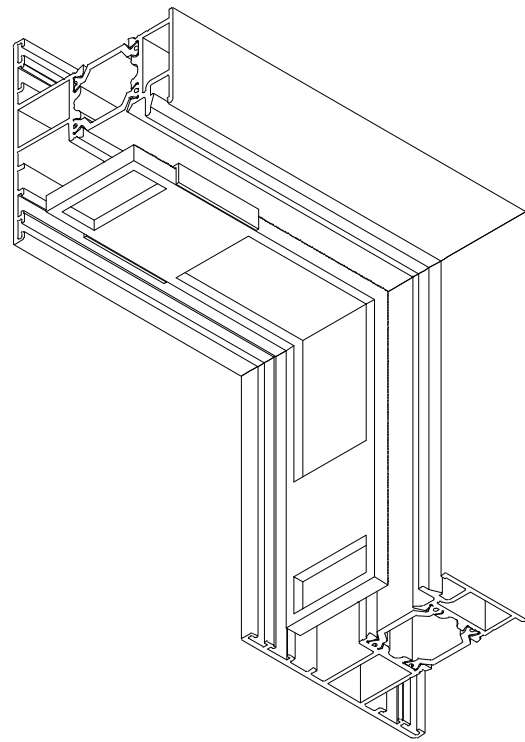


Internally Beaded Sections

- ETC6101
- ETC6301
- ETC623
- ETC624
- ETC628
- ETC647



ACET695 Glass Adjuster



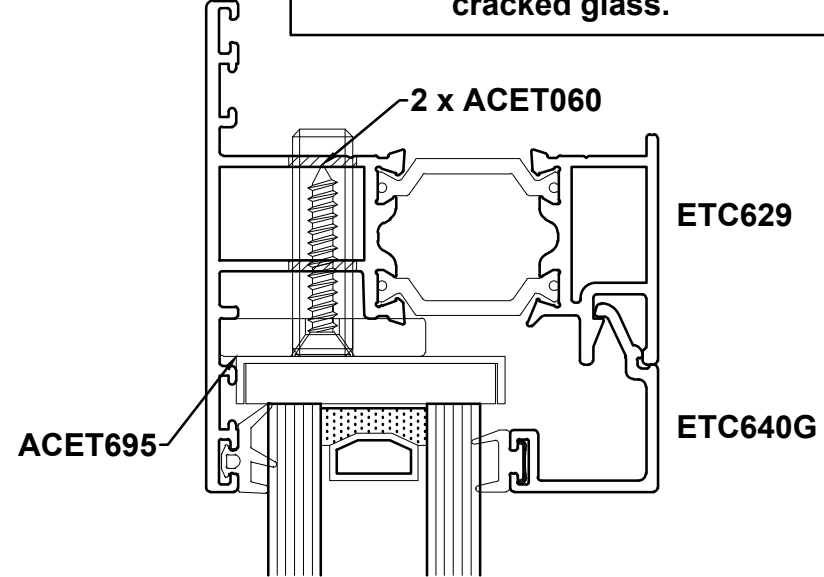
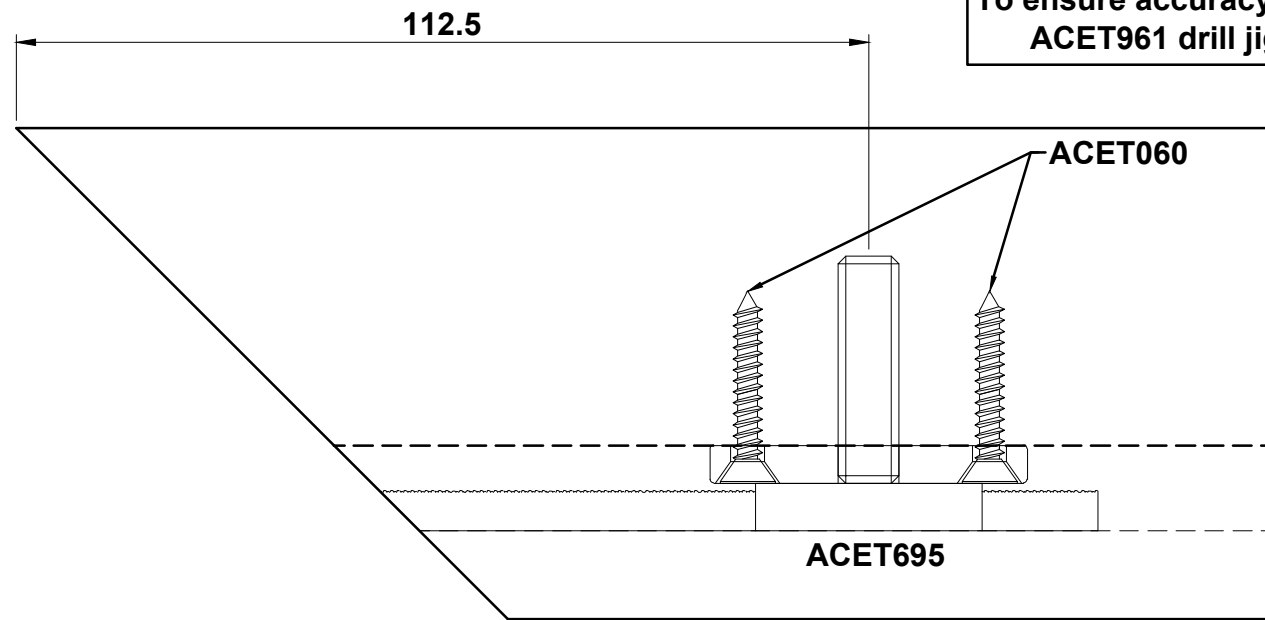
ETC629

ETC629

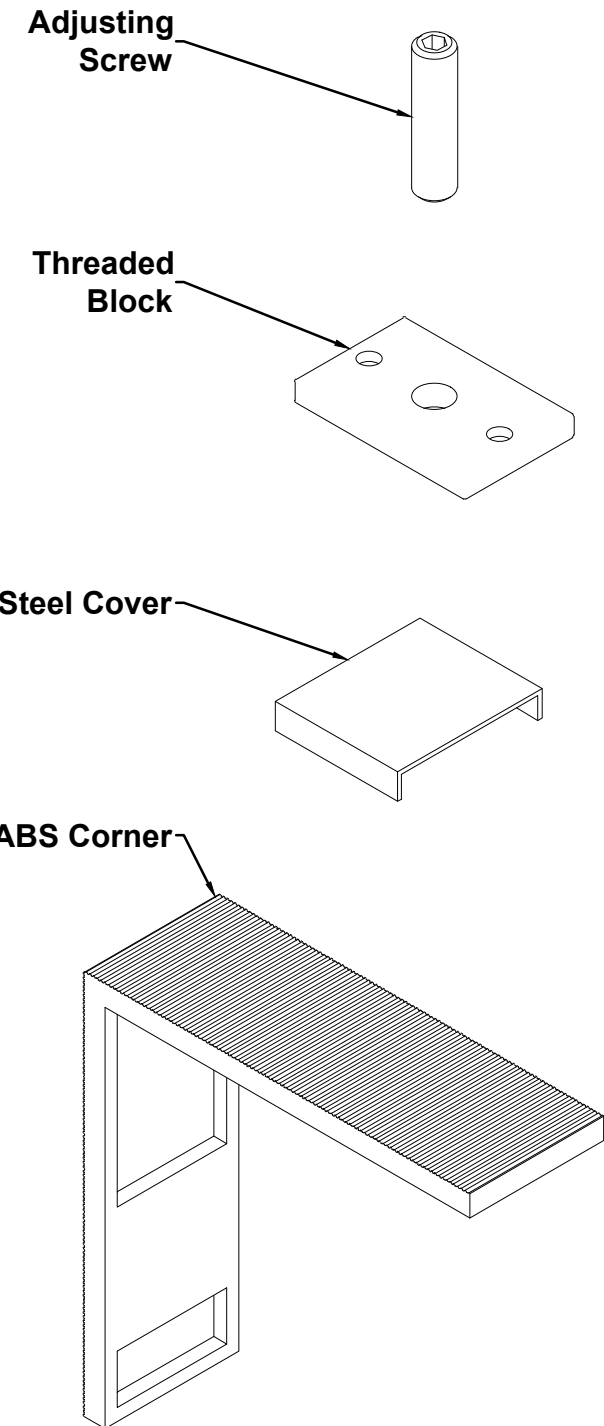
ETC640G

To ensure accuracy use ACET961 drill jig

Note: Do not tighten the adjusting screw too tightly as it can lead to cracked glass.



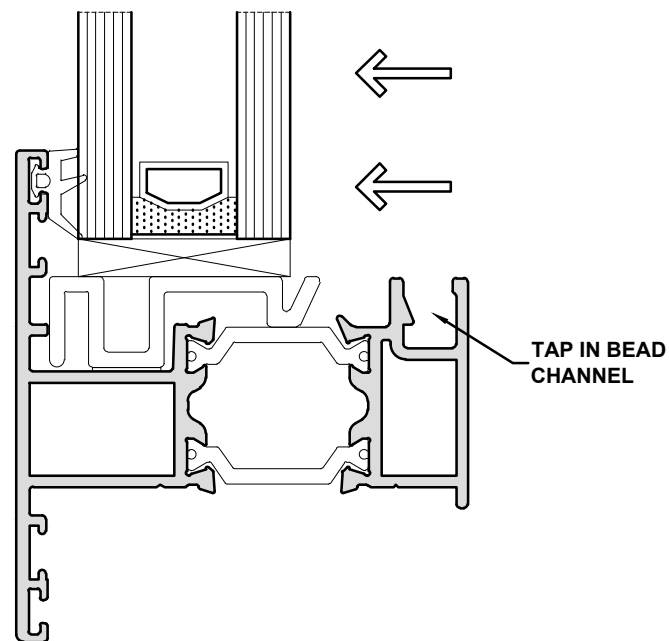
ACET695 Kit Includes:



Tap in Bead Installation and Removal

TAP IN BEAD INSTALLATION

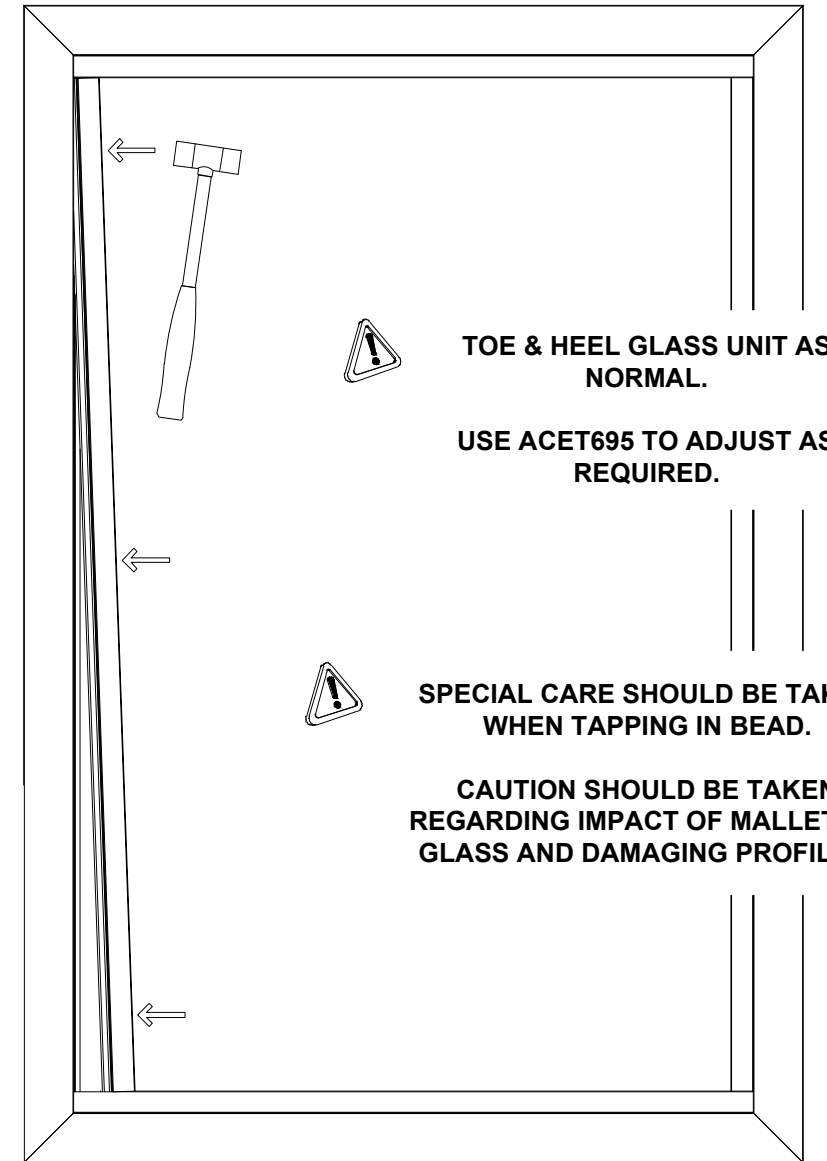
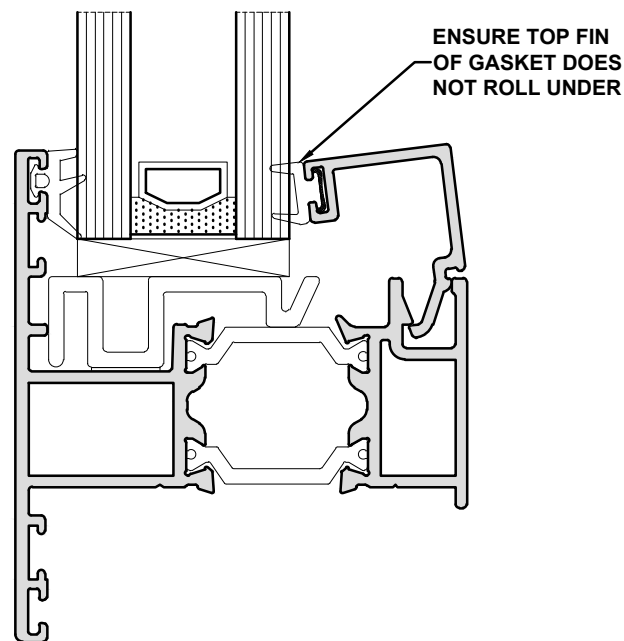
1. INSTALL GLASS UNIT, ENSURING IT HAS BEEN PUSHED FORWARD TO ENGAGE COMPRESSION OF E GASKET.
2. BEGINNING WITH HORIZONTAL BEADS, LOCATE BEAD IN CLIP CHANNEL OF SASH AS SHOWN. CO-EXTRUDED GASKET MAY REST AGAINST GLASS UNIT.
3. APPLY FIRM PRESSURE TO THE BEAD TO HOLD IN POSITION. THIS MAY CAUSE THE BEAD TO FULLY LOCK INTO POSITION.
4. USING A NYLON MALLET, TAP BEAD INTO CHANNEL WORKING FROM ONE END TO THE OTHER. PLEASE TAKE CARE AT THIS STAGE TO AVOID DAMAGE TO BOTH THE GLAZING UNIT AND THE BEAD.
5. REPEAT STEPS 2 - 4 TO INSTALL VERTICAL BEADS.



TAP IN BEAD REMOVAL

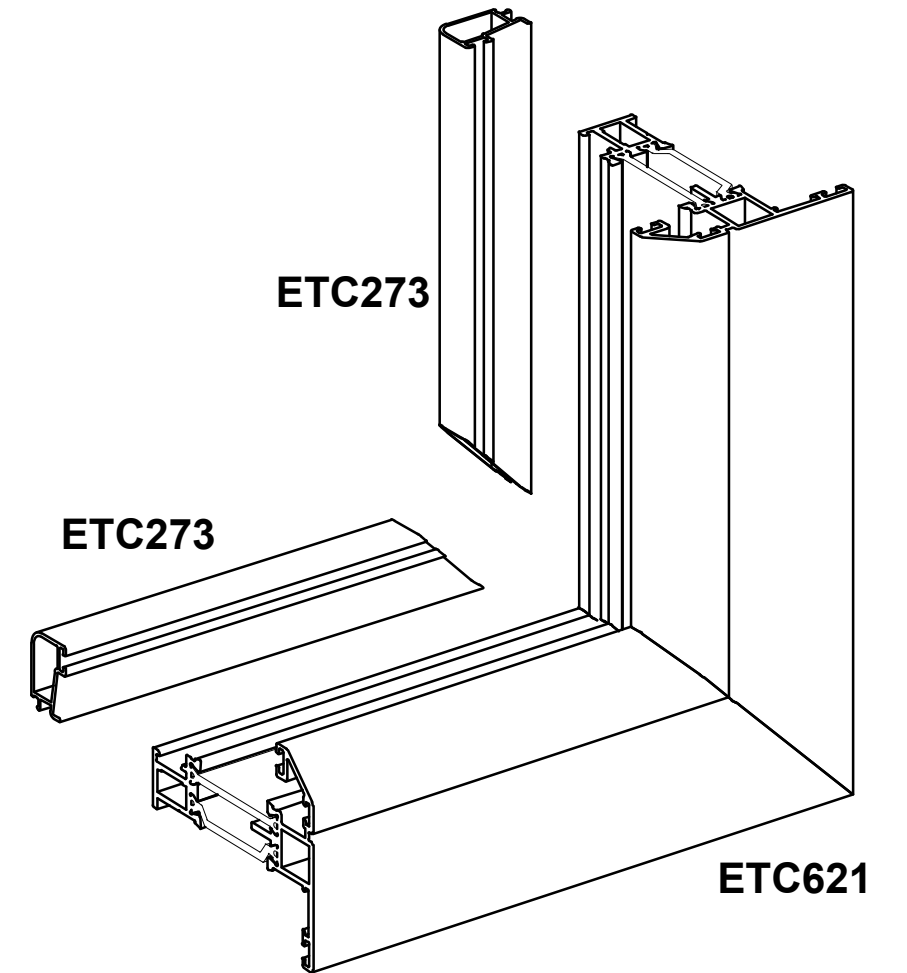
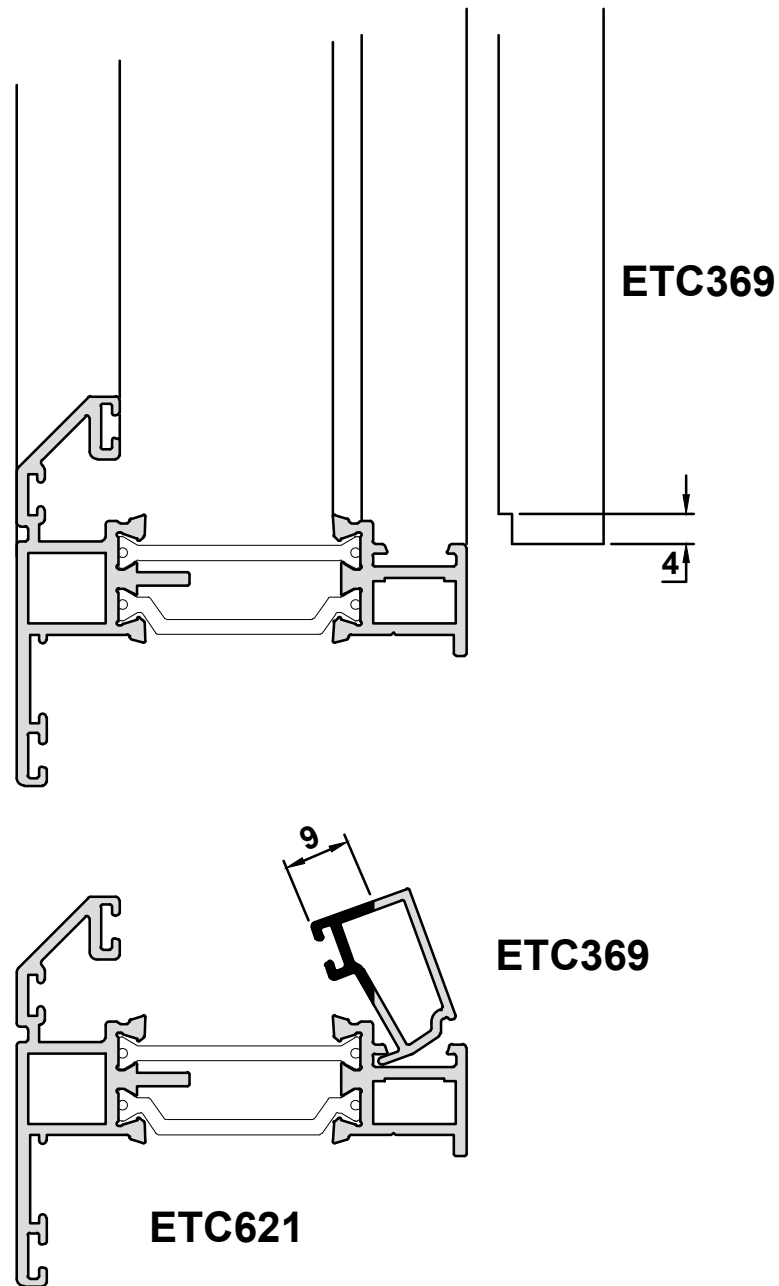
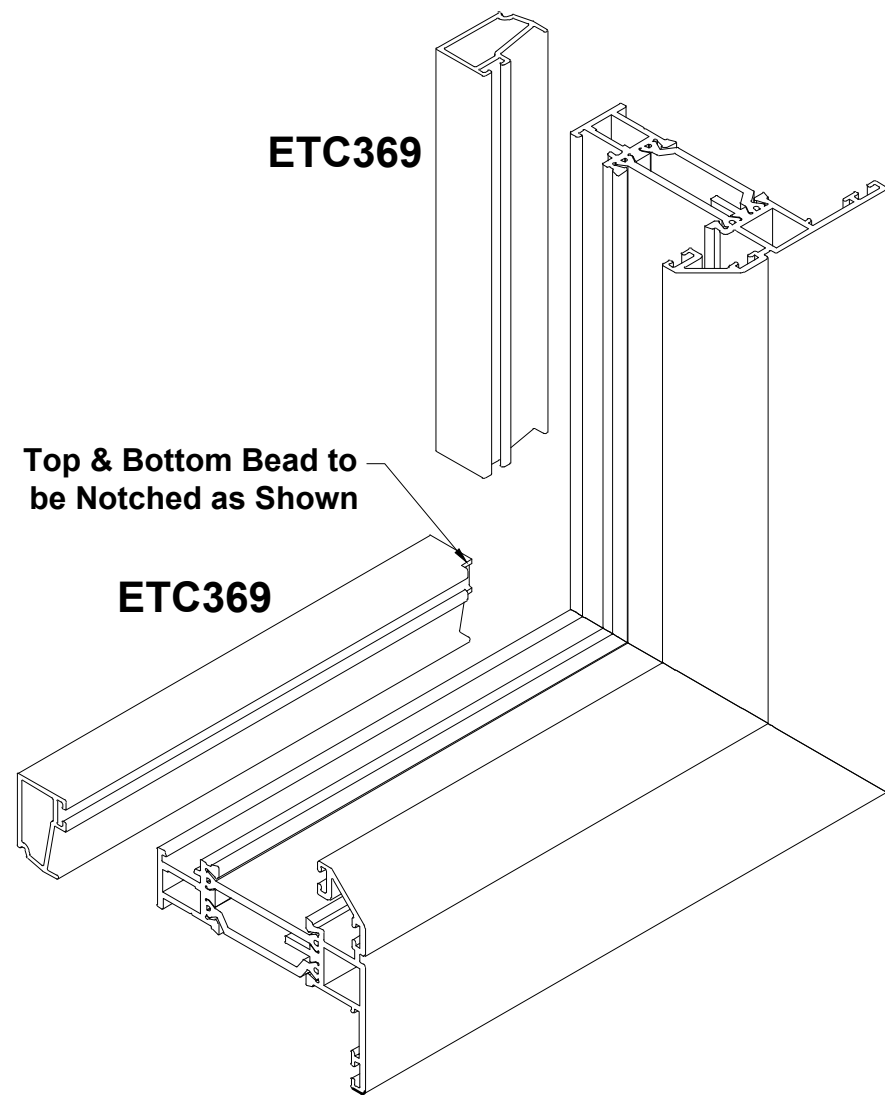
1. USING SMALL FLAT HEADED SCREWDRIVER OR SIMILAR, WEDGE TIP BETWEEN CO EXTRUDED GASKET AND ALUMINIUM.
2. IN A LEVERING MOTION, PRISE THE GASKET AWAY FROM THE ALUMINIUM. PARTICULAR CARE SHOULD BE TAKEN NOT TO DAMAGE THE GLASS UNIT AND ALUMINIUM.
3. COMPLETE THIS AT SEVERAL LOCATIONS ALONG THE LENGTH OF THE BEAD.
4. REMOVE GASKET AND DISCARD. THIS GASKET CAN NO LONGER BE USED.
5. THE BEAD SHOULD NOW BE EASILY REMOVABLE FROM TAP IN BEAD CHANNEL IN SASH

PLEASE SEE GLAZING CHART FOR REPLACEMENT GASKET CODES.



Do Not Scale From This Drawing

ETC369 & ETC273 Bead Preparation



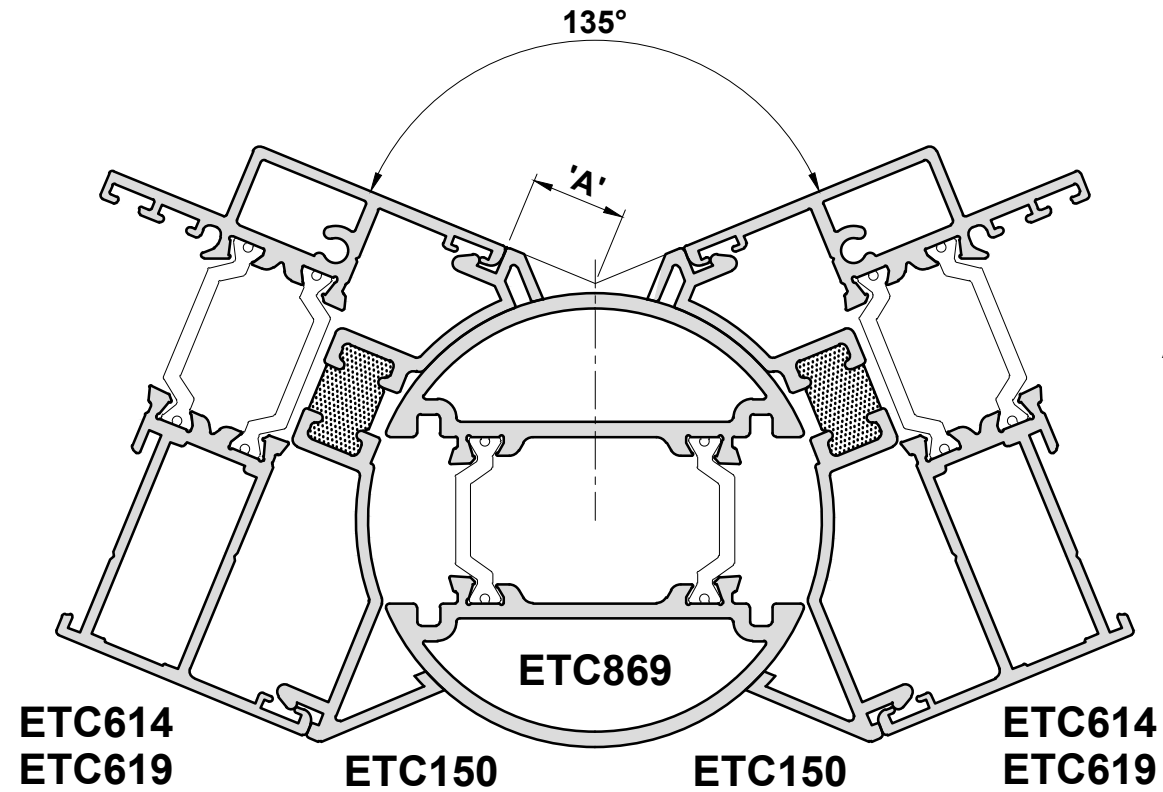
ETC273



**ETC273 should be mitred.
The beads to the handle side must be fitted last, then the handle block ACET367 or ACET368 can be fitted.**

Do Not Scale From This Drawing

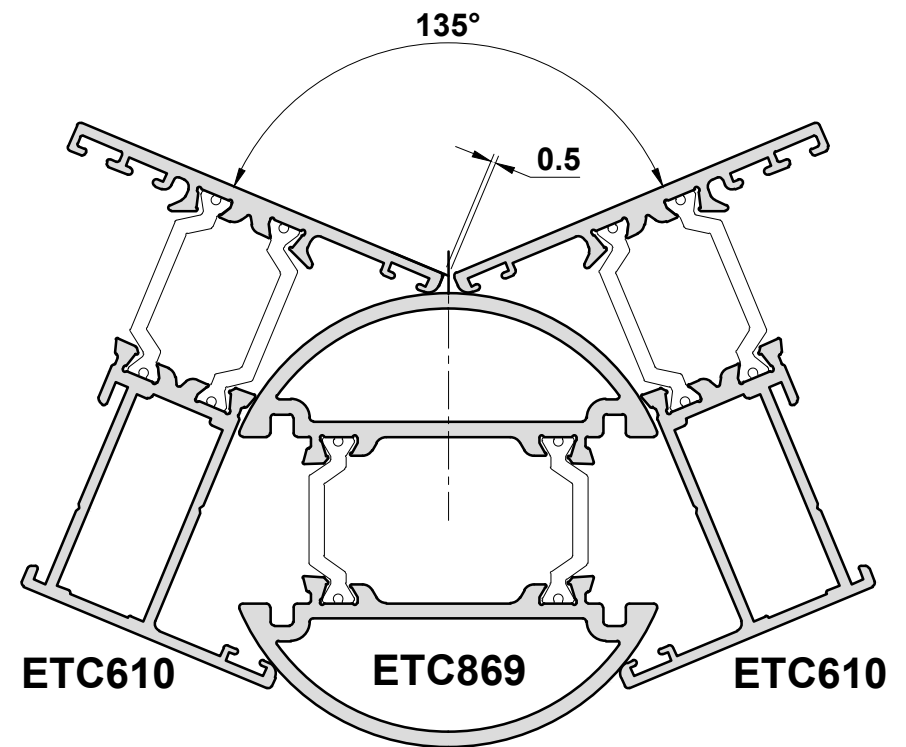
Bay Pole Angles/Deductions



ETC150 is NOT available in dual colour

ACSIL04
ACSIL08

Important Note:
All joints must be adequately sealed using ACSIL04

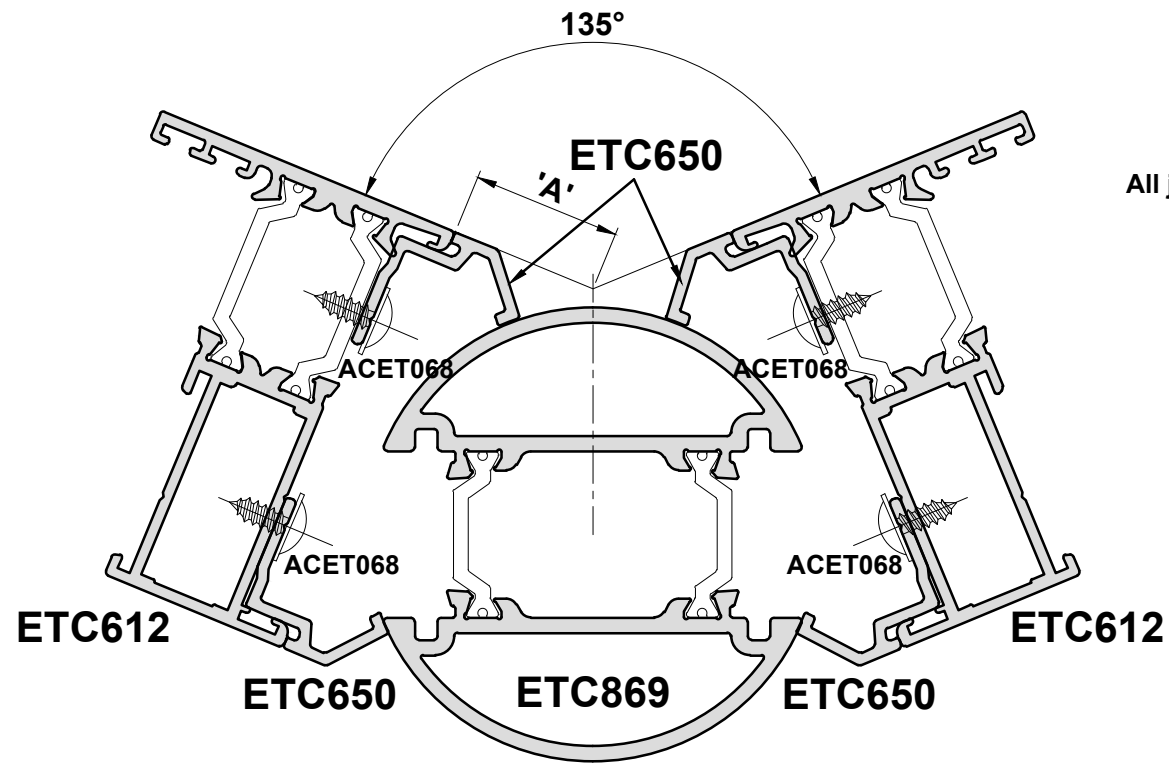


ANGLE	DEDUCTION 'A'
180°	24.5
175°	23.5
170°	22
165°	20.5
160°	19
155°	18
150°	16.5
145°	15
140°	13.5
135°	12
130°	11
125°	9.5
120°	8
115°	6
110°	4.5

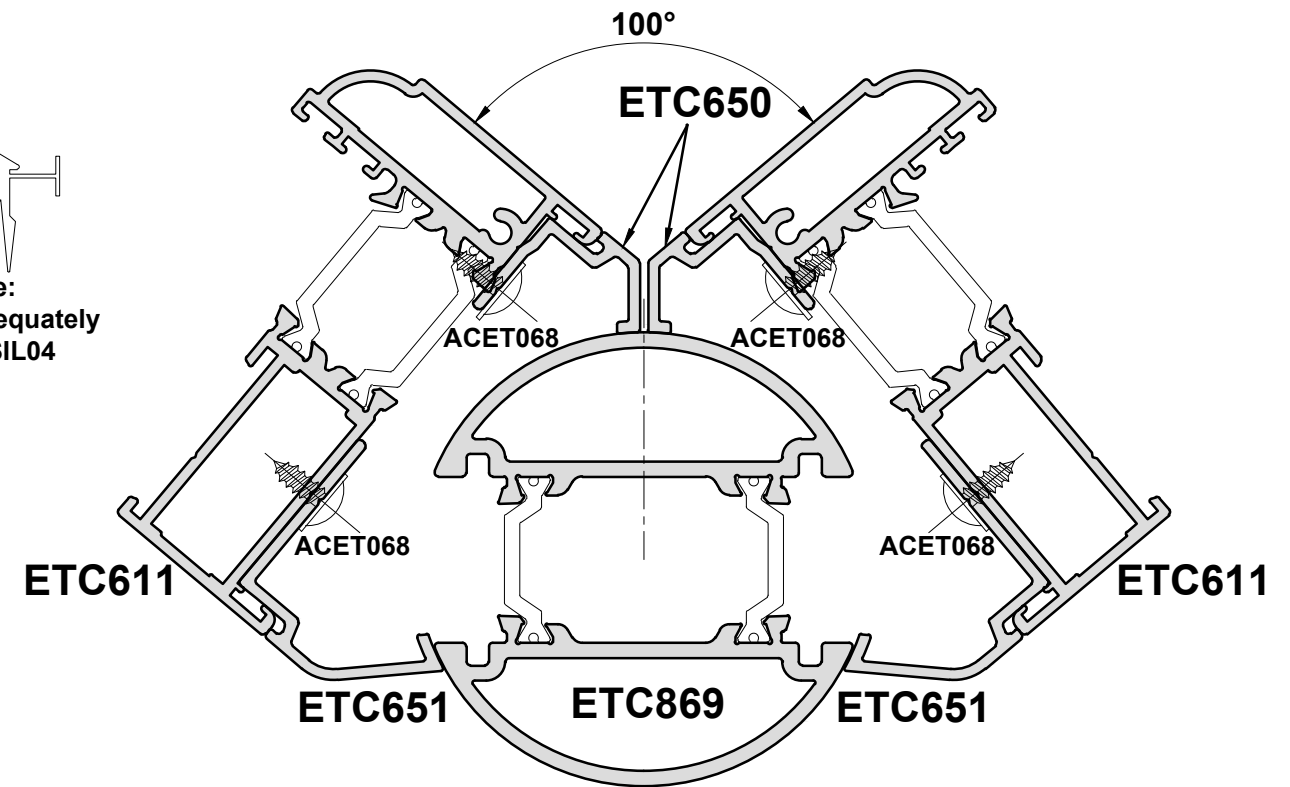
ANGLE	DEDUCTION 'A'
180°	13
175°	11.5
170°	10.5
165°	9
160°	8
155°	6.5
150°	5
145°	3.5
140°	2
135°	0.5

Do Not Scale From This Drawing

Bay Pole Angles/Deductions



Important Note:
All joints must be adequately sealed using ACSIL04

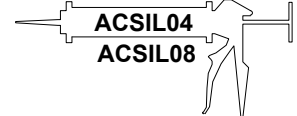
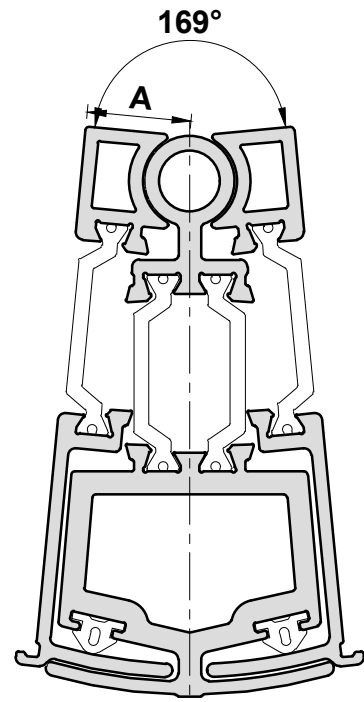


ANGLE	DEDUCTION 'A'
180°	32
175°	30.5
170°	29.5
165°	28.5
160°	27
155°	25.5
150°	24
145°	23
140°	21.5
135°	19.5

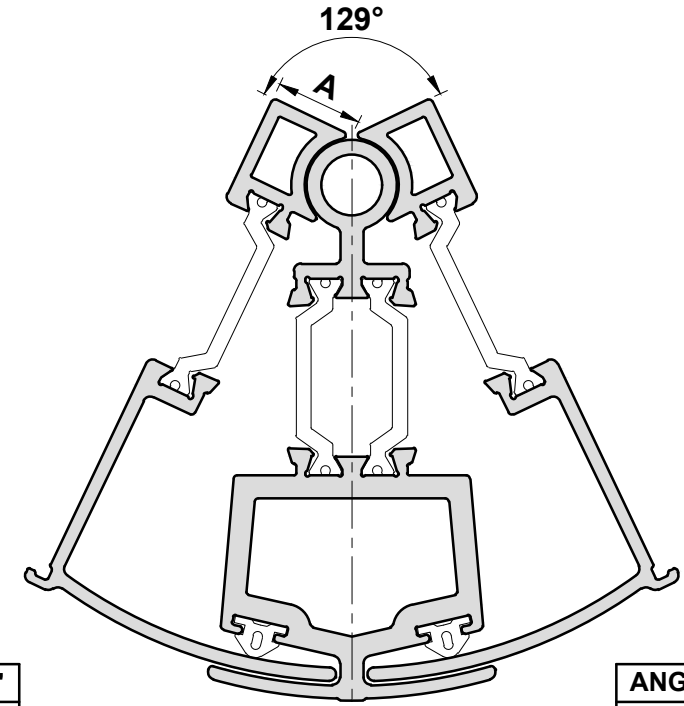
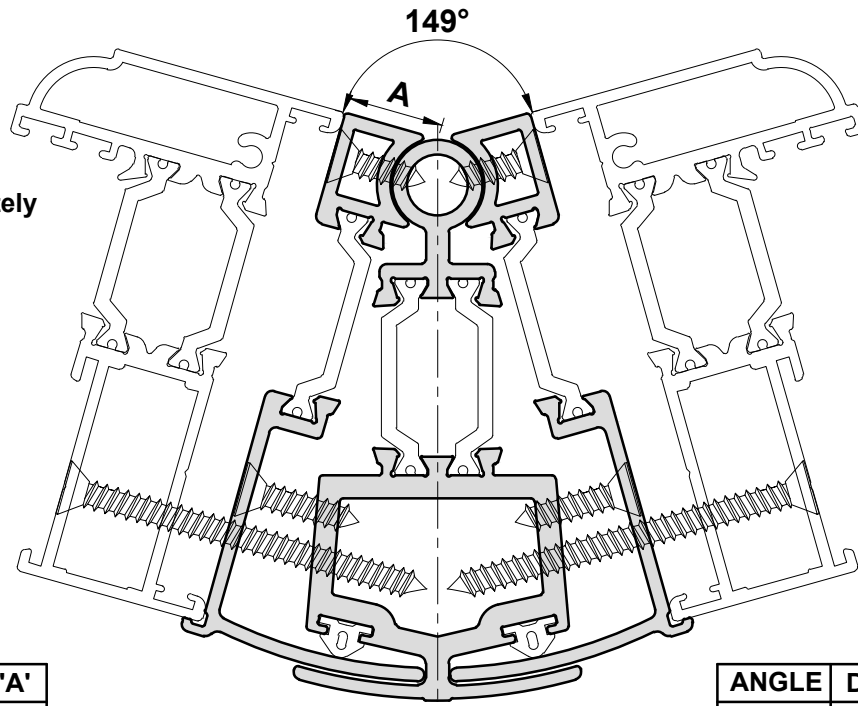
ANGLE	DEDUCTION 'A'
180°	32
175°	30.5
170°	29.5
165°	28
160°	26.5
155°	25.5
150°	24
145°	22.5
140°	21
135°	19.5
130°	18
125°	16.5
120°	14.5
115°	13
110°	11
105°	9
100°	7

Do Not Scale From This Drawing

70mm Outer Frame Bay Pole Angles/Deductions



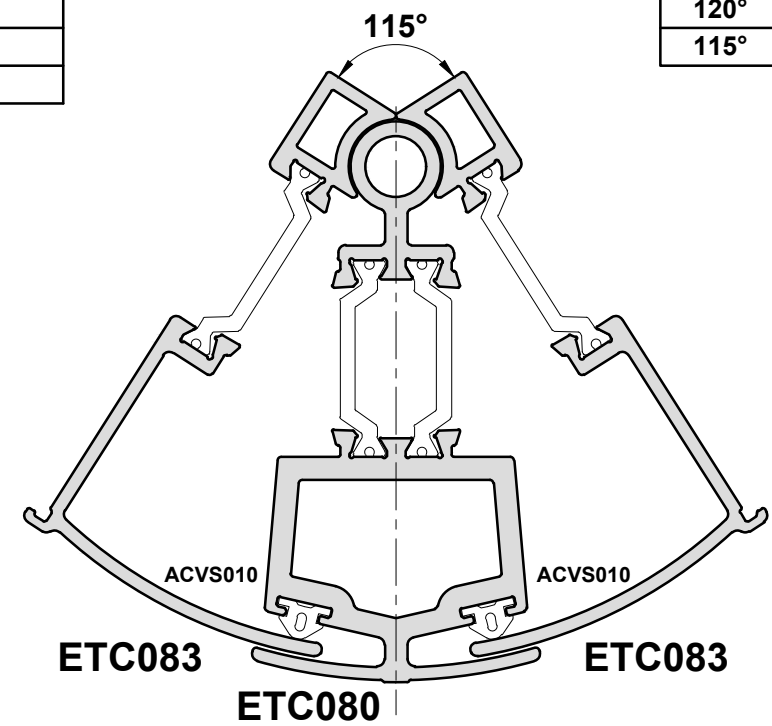
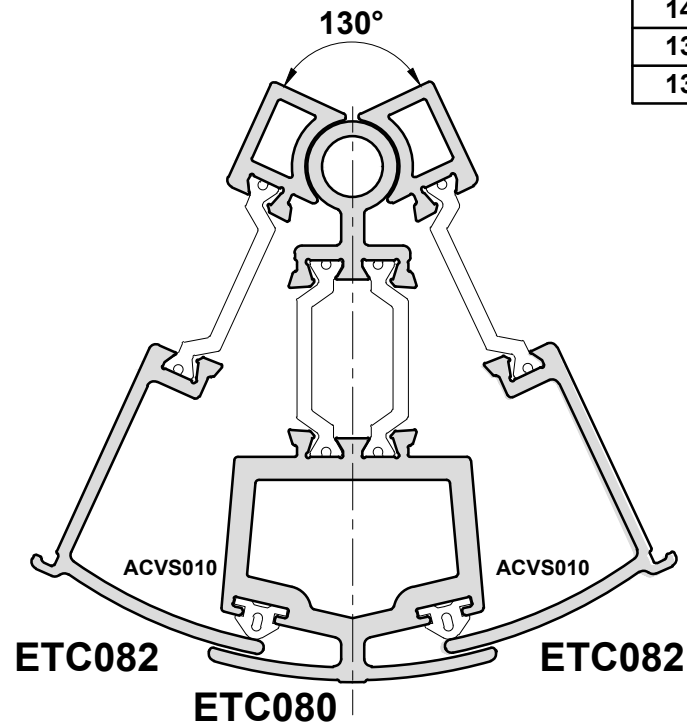
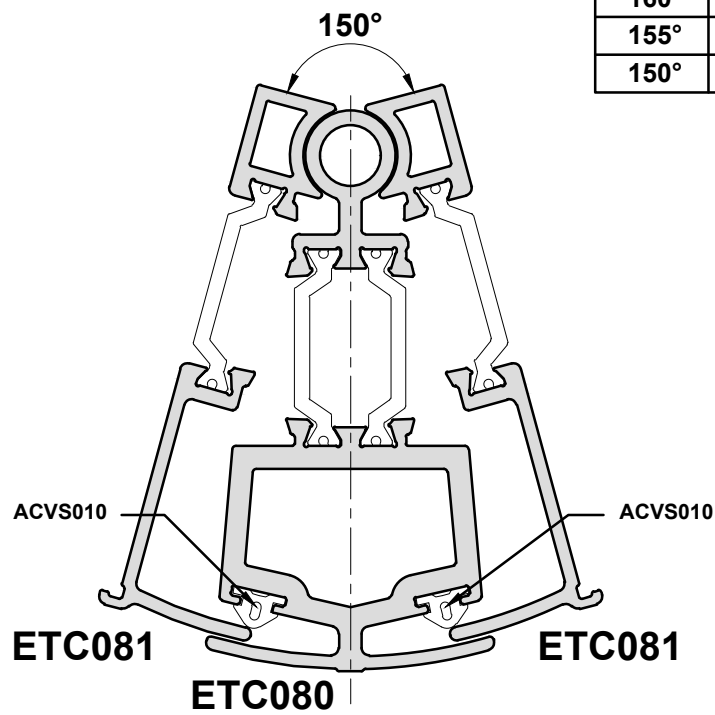
Important Note:
All joints must be adequately sealed using ACSIL04



ANGLE	DEDUCTION 'A'
169°	14
165°	13.5
160°	13.6
155°	13
150°	13

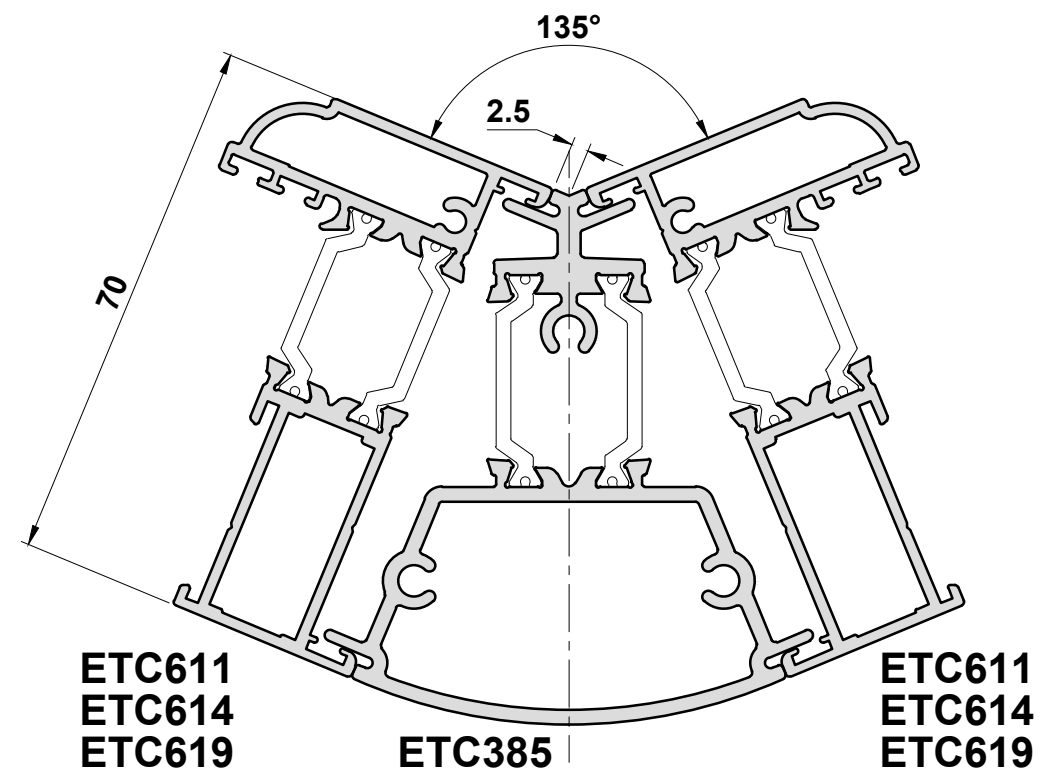
ANGLE	DEDUCTION 'A'
149°	12.5
145°	12.5
140°	12
135°	12
130°	11.5

ANGLE	DEDUCTION 'A'
129°	11.5
125°	11.5
120°	11
115°	10.5



Do Not Scale From This Drawing

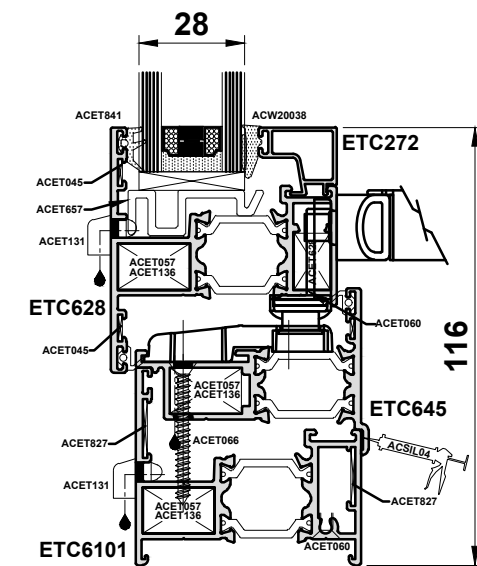
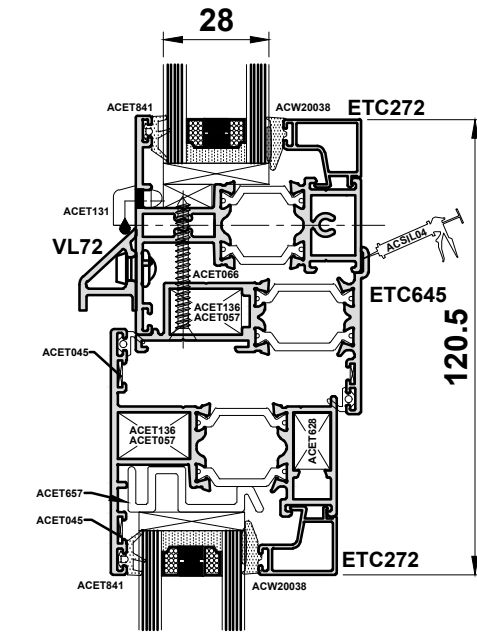
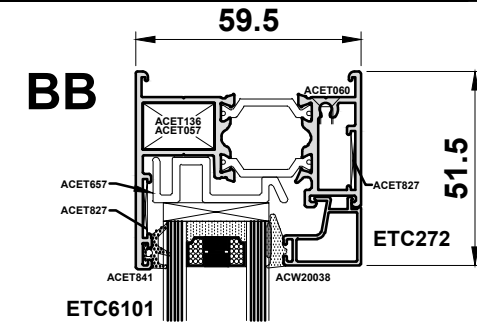
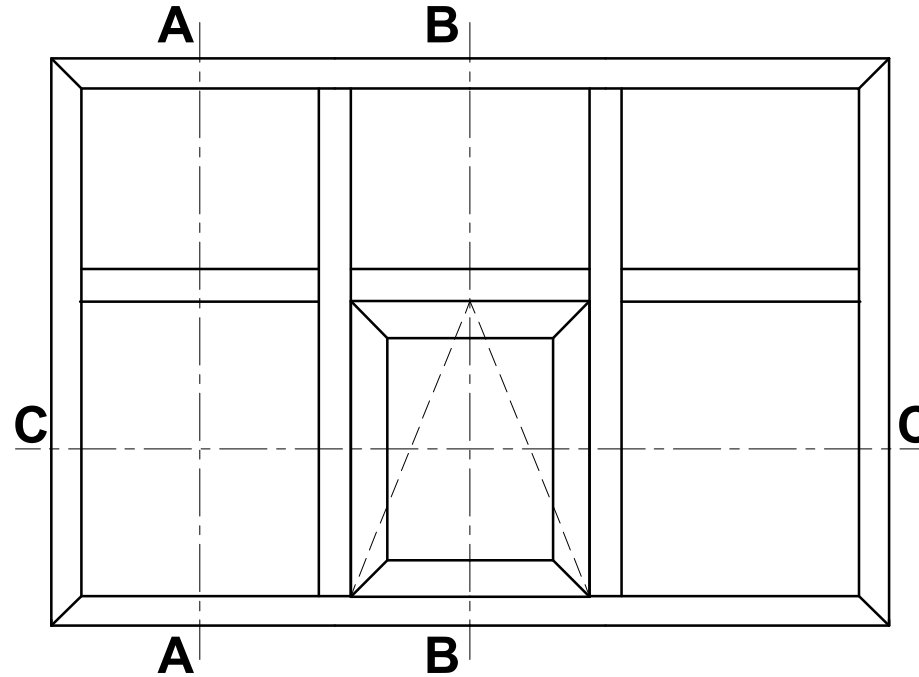
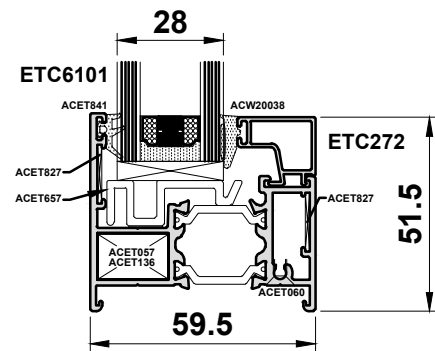
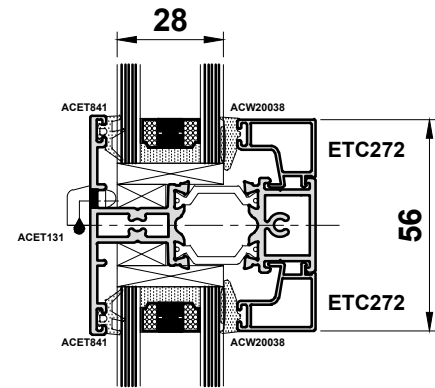
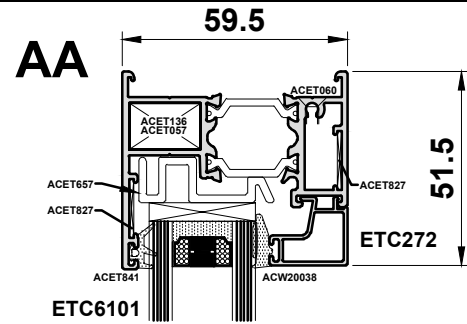
ETC385 Bay Pole Deductions



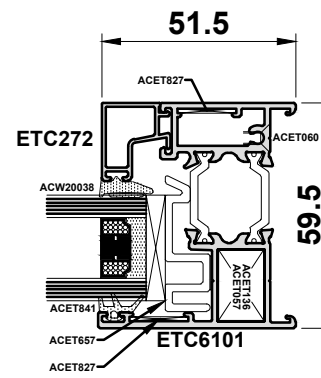
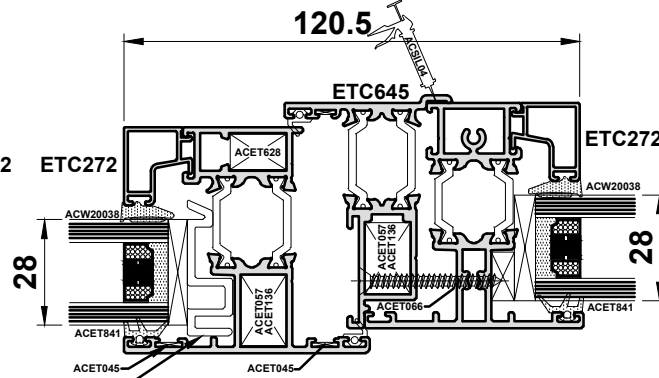
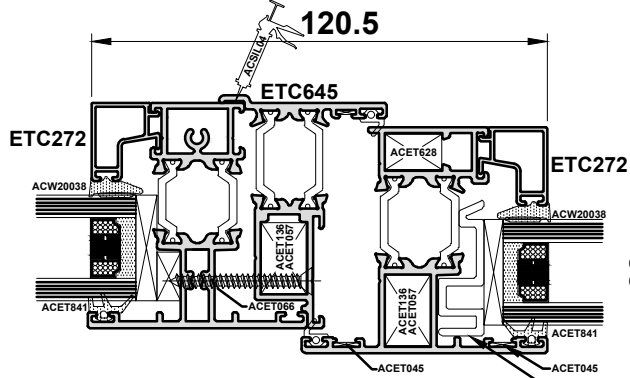
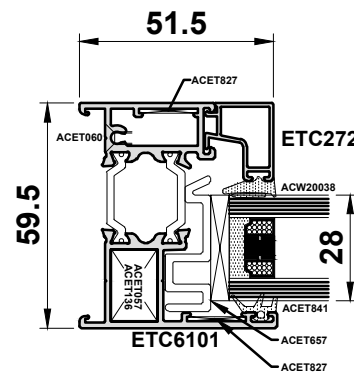
Note: ETC385 cannot be used with ETC615

Do Not Scale From This Drawing

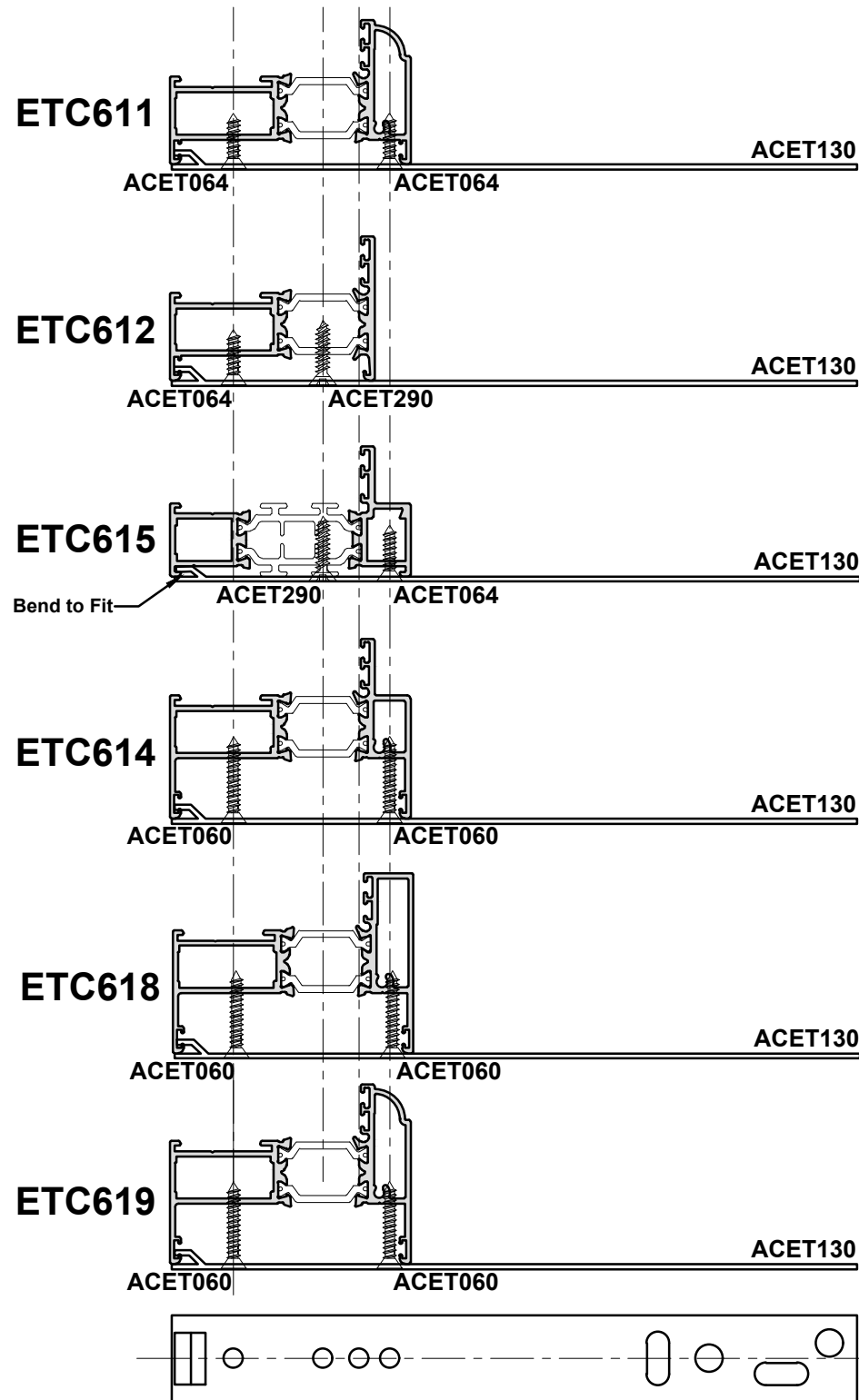
Internally Glazed Example



CC

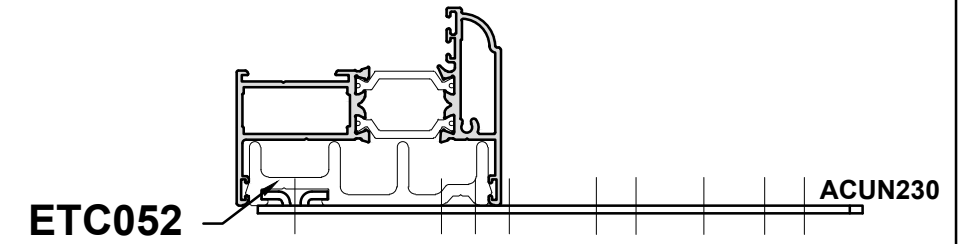
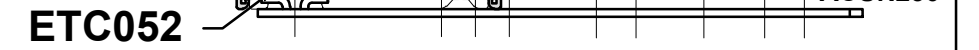


Do Not Scale From This Drawing

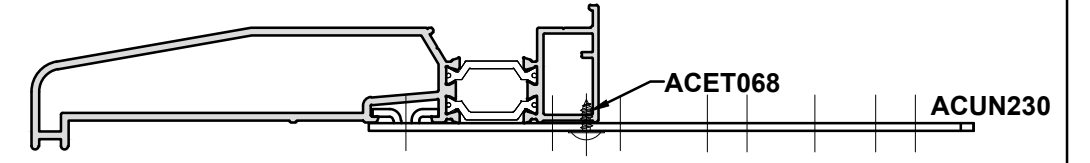


NOTE:
Fixing straps should be spaced a minimum of 150mm in from each end & at a maximum of 300mm apart.

ACUN230
2mm Galvanised Steel

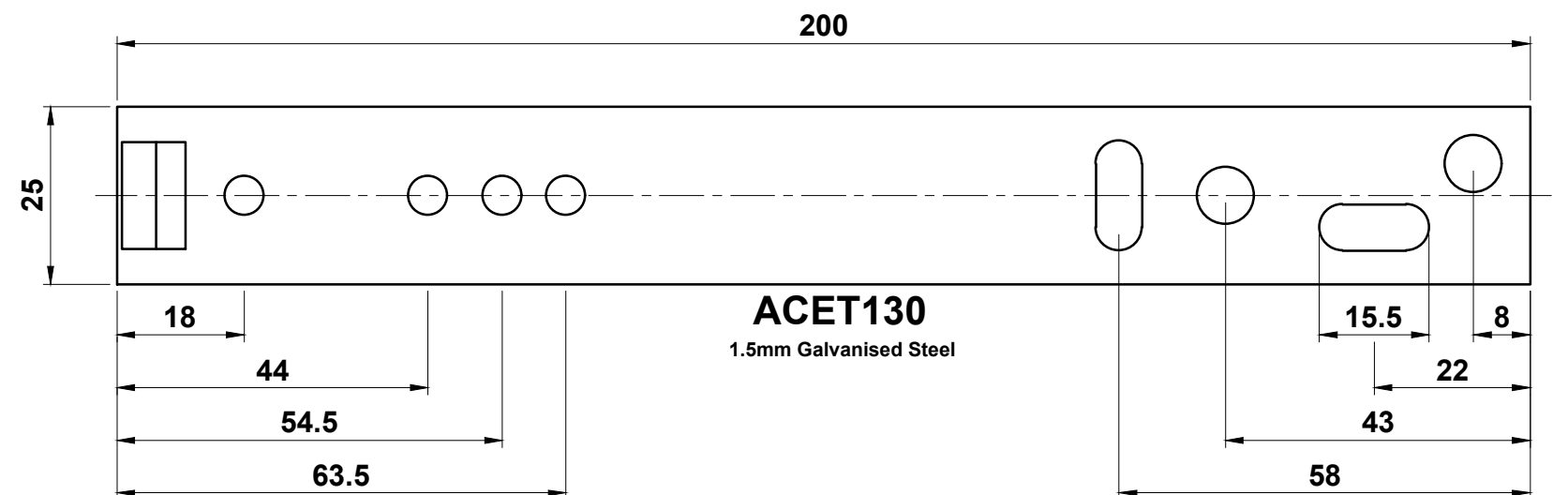
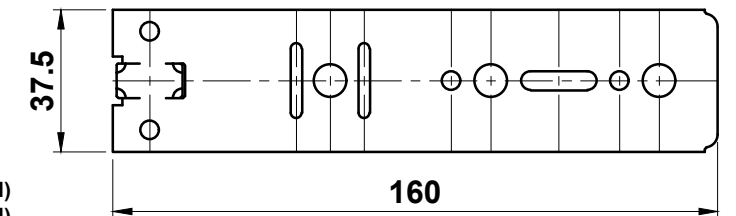


ETC451
ETC452
ETC457
ETC457
ETC479



Other available fixing straps:

ACUN232 - 240mm Fixing Strap (2mm Galvanised Steel)
ACUN233 - 280mm Fixing Strap (2mm Galvanised Steel)

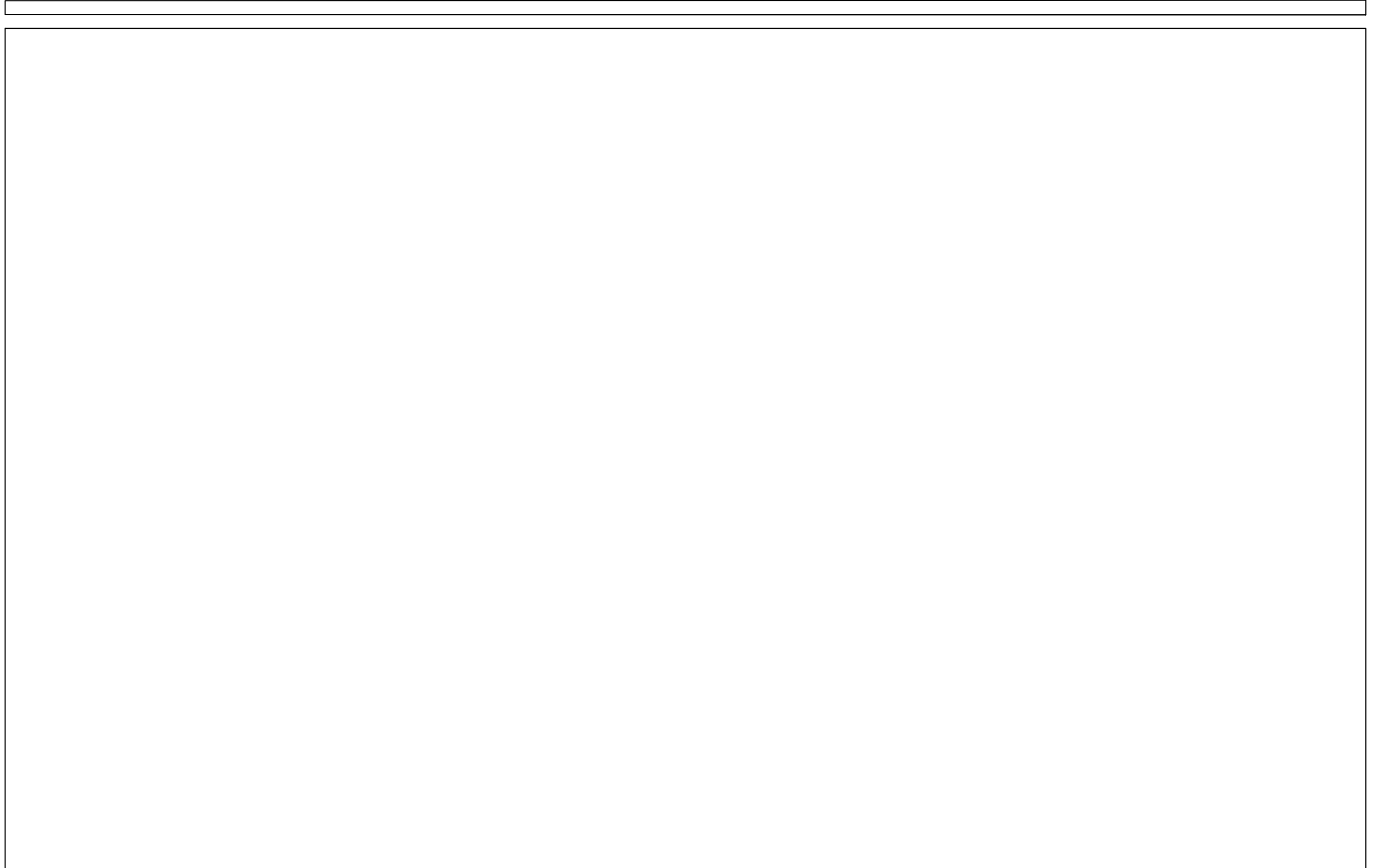


Do Not Scale From This Drawing

Section F

Sawing Tables

Cutting Information



Cutting Information

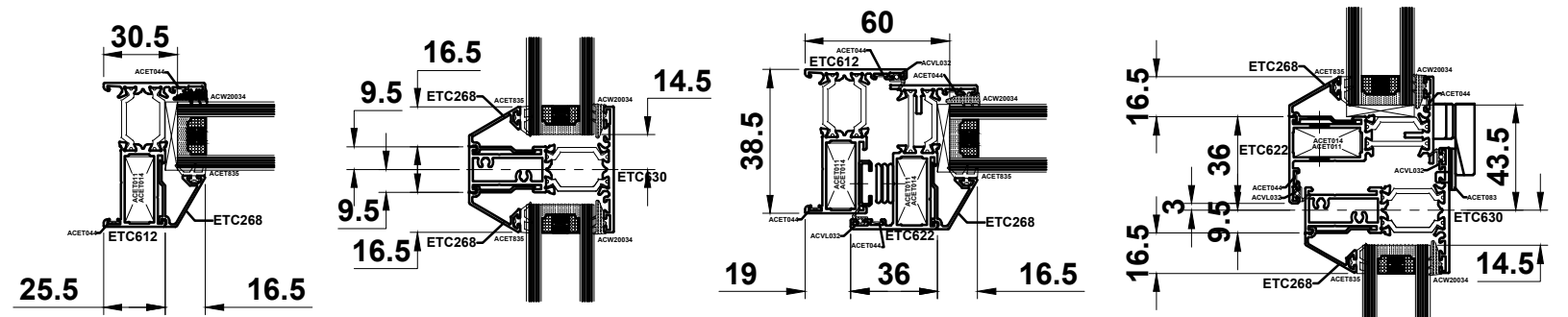
PART DESCRIPTIONS	TYPICAL STYLES	[Icons representing various window styles]															
		[Icon 1]	[Icon 2]	[Icon 3]	[Icon 4]	[Icon 5]	[Icon 6]	[Icon 7]	[Icon 8]	[Icon 9]	[Icon 10]	[Icon 11]	[Icon 12]	[Icon 13]	[Icon 14]	[Icon 15]	
Outer Frame	Head & Cill	W	W	W	W	W	W	W	W	W	W	W	W	W	W	W	
	Jambs	H	H	H	H	H	H	H	H	H	H	H	H	H	H	H	
	Transoms		W - 51		W - 51	W - 51	W - 51		OF to €M - 35	W - 51		OF to €M - 35	€M to €M - 19	W - 51	OF to €M - 35	W - 51	
	Mullions								H - 51	H - 51	OF to €T - 35	H - 51	H - 51	H - 51	OF to €T - 35	H - 51	
Vent (1)	Horizontal Components			W - 38	W - 38	W - 38	W - 38	OF to €M - 22	OF to €M - 22	OF to €M - 22	OF to €M - 22	OF to €M - 22	OF to €M - 22	OF to €M - 22	OF to €M - 22	W - 38	
	Vertical Components			H - 38	OF to €T - 22	OF to €T - 22	€T to €T - 6	H - 38	H - 38	OF to €T - 22	H - 38	OF to €T - 22	H - 38	OF to €T - 22	OF to €T - 22	OF to €T - 22	
Vent (2)	Horizontal Components					W - 38			OF to €M - 22			OF to €M - 22	€M to €M - 6	€M to €M - 6	OF to €M - 22		
	Vertical Components					OF to €T - 22			OF to €T - 22			OF to €T - 22	OF to €T - 22	OF to €T - 22	OF to €T - 22		
Vent (1)	Glass Width			W - 120	W - 120	W - 120	W - 120	OF to €M - 103.5	OF to €M - 103.5	OF to €M - 103.5	OF to €M - 103.5	OF to €M - 103.5	OF to €M - 103.5	OF to €M - 103.5	OF to €M - 103.5	W - 120	
	Glass Height			H - 120	OF to €T - 103.5	OF to €T - 103.5	€T to €T - 87	H - 120	H - 120	OF to €T - 103.5	H - 120	OF to €T - 103.5	H - 120	OF to €T - 103.5	OF to €T - 103.5	OF to €T - 103.5	
Vent (2)	Glass Width					W - 120			OF to €M - 103.5			OF to €M - 103.5	€M to €M - 87	€M to €M - 87	OF to €M - 103.5		
	Glass Height					OF to €T - 103.5			OF to €T - 103.5			OF to €T - 103.5	OF to €T - 103.5	OF to €T - 103.5	OF to €T - 103.5		
Fixed Panel (1)	Glass Width	W - 61	W - 61		W - 61		W - 61	OF to €M - 45	OF to €M - 45	W - 61	€M to €M - 29	€M to €M - 29	€M to €M - 29	W - 61	OF to €M - 45	W - 61	
	Glass Height	H - 61	OF to €T - 45		OF to €T - 45		OF to €T - 45	H - 61	OF to €T - 45	OF to €T - 45	H - 61	H - 61	OF to €T - 45	OF to €T - 45	H - 61	OF to €T - 45	

LEGEND:

- W = Overall window outer frame width - outside
- H = Overall window outer frame height - outside
- € = Centre line of transom/mullion
- O/F = Extreme edge of outer frame

Sections:

- Outerframe: ETC612
- Sash: ETC622
- Transom/Mullion: ETC630



Do Not Scale From This Drawing

Cutting Information

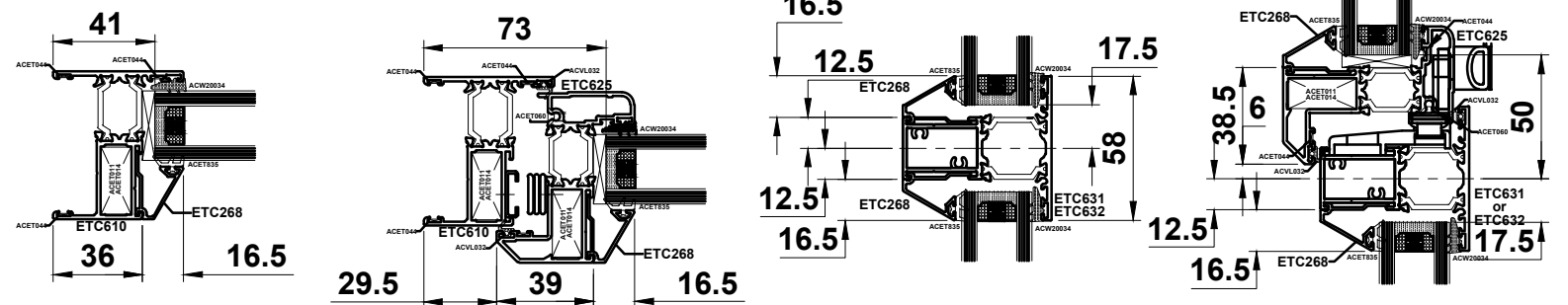
PART DESCRIPTIONS	TYPICAL STYLES	[Icons representing different window styles]															
		[Icon 1]	[Icon 2]	[Icon 3]	[Icon 4]	[Icon 5]	[Icon 6]	[Icon 7]	[Icon 8]	[Icon 9]	[Icon 10]	[Icon 11]	[Icon 12]	[Icon 13]	[Icon 14]	[Icon 15]	
Outer Frame	Head & Cill	W	W	W	W	W	W	W	W	W	W	W	W	W	W	W	
	Jambs	H	H	H	H	H	H	H	H	H	H	H	H	H	H	H	
	Transoms		W - 72		W - 72	W - 72	W - 72		OF to €M - 48.5	W - 72		OF to €M - 48.5	€M to €M - 25	W - 72	OF to €M - 48.5	W - 72	
	Mullions							H - 72	H - 72	OF to €T - 48.5	H - 72	H - 72	H - 72	OF to €T - 48.5	H - 72		
Vent (1)	Horizontal Components			W - 59	W - 59	W - 59	W - 59	OF to €M - 35.5	OF to €M - 35.5	OF to €M - 35.5	OF to €M - 35.5	OF to €M - 35.5	OF to €M - 35.5	OF to €M - 35.5	OF to €M - 35.5	W - 59	
	Vertical Components			H - 59	OF to €T - 35.5	OF to €T - 35.5	€T to €T - 12	H - 59	H - 59	OF to €T - 35.5	H - 59	OF to €T - 35.5	H - 59	OF to €T - 35.5	OF to €T - 35.5	OF to €T - 35.5	
Vent (2)	Horizontal Components					W - 59		OF to €M - 35.5				OF to €M - 35.5	€M to €M - 12	€M to €M - 12	OF to €M - 35.5		
	Vertical Components					OF to €T - 35.5		OF to €T - 35.5				OF to €T - 35.5	OF to €T - 35.5	OF to €T - 35.5	OF to €T - 35.5		
Vent (1)	Glass Width			W - 146	W - 146	W - 146	W - 146	OF to €M - 123	OF to €M - 123	OF to €M - 123	OF to €M - 123	OF to €M - 123	OF to €M - 123	OF to €M - 123	OF to €M - 123	W - 146	
	Glass Height			H - 146	OF to €T - 123	OF to €T - 123	€T to €T - 100	H - 146	H - 146	OF to €T - 123	H - 146	OF to €T - 123	H - 146	OF to €T - 123	OF to €T - 123	OF to €T - 123	
Vent (2)	Glass Width					W - 146		OF to €M - 123				OF to €M - 123	€M to €M - 100	€M to €M - 100	OF to €M - 123		
	Glass Height					OF to €T - 123		OF to €T - 123				OF to €T - 123	OF to €T - 123	OF to €T - 123	OF to €T - 123		
Fixed Panel (1)	Glass Width	W - 82	W - 82		W - 82		W - 82	OF to €M - 58.5	OF to €M - 58.5	W - 82	€M to €M - 35	€M to €M - 35	€M to €M - 35	W - 82	OF to €M - 58.5	W - 82	
	Glass Height	H - 82	OF to €T - 58.5		OF to €T - 58.5		OF to €T - 58.5	H - 82	OF to €T - 58.5	OF to €T - 58.5	H - 82	H - 82	OF to €T - 58.5	OF to €T - 58.5	H - 82	OF to €T - 58.5	

LEGEND:

- W = Overall window outer frame width - outside
- H = Overall window outer frame height - outside
- € = Centre line of transom/mullion
- O/F = Extreme edge of outer frame

Sections:

- Outerframe: ETC610, ETC614, ETC619
- Sash: ETC620, ETC625
- Transom/Mullion: ETC631, ETC632



Do Not Scale From This Drawing

Cutting Information

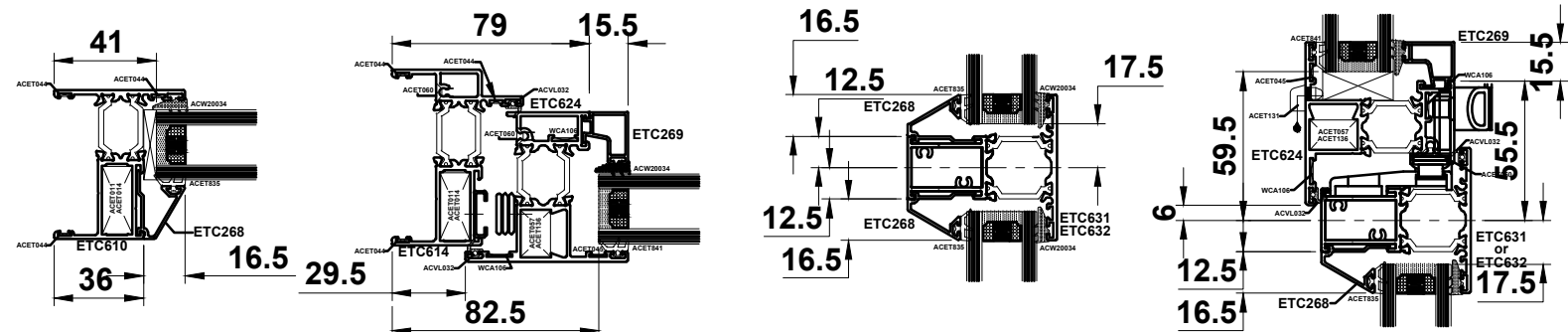
PART DESCRIPTIONS	TYPICAL STYLES	[Icons representing various window styles]															
		[Icon 1]	[Icon 2]	[Icon 3]	[Icon 4]	[Icon 5]	[Icon 6]	[Icon 7]	[Icon 8]	[Icon 9]	[Icon 10]	[Icon 11]	[Icon 12]	[Icon 13]	[Icon 14]	[Icon 15]	
Outer Frame	Head & Cill	W	W	W	W	W	W	W	W	W	W	W	W	W	W	W	
	Jambs	H	H	H	H	H	H	H	H	H	H	H	H	H	H	H	
	Transoms		W - 72		W - 72	W - 72	W - 72		OF to €M - 48.5	W - 72		OF to €M - 48.5	€M to €M - 25	W - 72	OF to €M - 48.5	W - 72	
	Mullions							H - 72	H - 72	OF to €T - 48.5	H - 72	H - 72	H - 72	OF to €T - 48.5	H - 72		
Vent (1)	Horizontal Components			W - 59	W - 59	W - 59	W - 59	OF to €M - 35.5	OF to €M - 35.5	OF to €M - 35.5	OF to €M - 35.5	OF to €M - 35.5	OF to €M - 35.5	OF to €M - 35.5	OF to €M - 35.5	W - 59	
	Vertical Components			H - 59	OF to €T - 35.5	OF to €T - 35.5	€T to €T - 12	H - 59	H - 59	OF to €T - 35.5	H - 59	OF to €T - 35.5	H - 59	OF to €T - 35.5	OF to €T - 35.5	OF to €T - 35.5	
Vent (2)	Horizontal Components					W - 59		OF to €M - 35.5				OF to €M - 35.5	€M to €M - 12	€M to €M - 12	OF to €M - 35.5		
	Vertical Components							OF to €T - 35.5				OF to €T - 35.5	OF to €T - 35.5	OF to €T - 35.5	OF to €T - 35.5		
Vent (1)	Glass Width			W - 165	W - 165	W - 165	W - 165	OF to €M - 142	OF to €M - 142	OF to €M - 142	OF to €M - 142	OF to €M - 142	OF to €M - 142	OF to €M - 142	OF to €M - 142	W - 165	
	Glass Height			H - 165	OF to €T - 142	OF to €T - 142	€T to €T - 119	H - 165	H - 165	OF to €T - 142	H - 165	OF to €T - 142	H - 165	OF to €T - 142	OF to €T - 142	OF to €T - 142	
Vent (2)	Glass Width					W - 165		OF to €M - 142				OF to €M - 142	€M to €M - 119	€M to €M - 119	OF to €M - 142		
	Glass Height							OF to €T - 142				OF to €T - 142	OF to €T - 142	OF to €T - 142	OF to €T - 142		
Fixed Panel (1)	Glass Width	W - 82	W - 82		W - 82		W - 82	OF to €M - 58.5	OF to €M - 58.5	W - 82	€M to €M - 35	€M to €M - 35	€M to €M - 35	W - 82	OF to €M - 58.5	W - 82	
	Glass Height	H - 82	OF to €T - 58.5		OF to €T - 58.5			OF to €T - 58.5	H - 82	OF to €T - 58.5	OF to €T - 58.5	H - 82	H - 82	OF to €T - 58.5	OF to €T - 58.5	H - 82	

LEGEND:

- W = Overall window outer frame width - outside
- H = Overall window outer frame height - outside
- € = Centre line of transom/mullion
- O/F = Extreme edge of outer frame

Sections:

- Outerframe: ETC610, ETC614, ETC619
- Sash: ETC623, ETC624
- Transom/Mullion: ETC631, ETC632



Do Not Scale From This Drawing

Cutting Information

PART DESCRIPTIONS	TYPICAL STYLES	CUTTING INFORMATION															
		①	① ①	①	①	①	①	①	①	①	①	①	①	①	①	①	
Outer Frame	Head & Cill	W	W	W	W	W	W	W	W	W	W	W	W	W	W	W	
	Jambs	H	H	H	H	H	H	H	H	H	H	H	H	H	H	H	
	Transoms		W - 29		W - 29	W - 29	W - 29		OF to €M - 17.5	W - 50		OF to €M - 17.5	€M to €M - 17.5	W - 50	OF to €M - 17.5	W - 50	
	Mullions							H - 29	H - 29	OF to €T - 6	H - 29	H - 29	H - 29	OF to €T - 6	H - 29		
Vent (1)	Horizontal Components			W - 38	W - 38	W - 38	W - 38	OF to €M - 26.5	OF to €M - 26.5	OF to €M - 26.5	OF to €M - 26.5	OF to €M - 26.5	OF to €M - 26.5	OF to €M - 26.5	OF to €M - 26.5	W - 38	
	Vertical Components			H - 38	OF to €T - 26.5	OF to €T - 26.5	€T to €T - 15	H - 38	H - 38	OF to €T - 26.5	H - 38	OF to €T - 26.5	H - 38	OF to €T - 26.5	OF to €T - 26.5	OF to €T - 26.5	
Vent (2)	Horizontal Components					W - 38		OF to €M - 26.5				OF to €M - 26.5	€M to €M - 15	€M to €M - 15	OF to €M - 15		
	Vertical Components						OF to €T - 26.5	OF to €T - 26.5				OF to €T - 26.5	OF to €T - 26.5	OF to €T - 26.5	OF to €T - 26.5		
Vent (1)	Glass Width			W - 145	W - 145	W - 145	W - 145	OF to €M - 133.5	OF to €M - 133.5	OF to €M - 133.5	OF to €M - 133.5	OF to €M - 133.5	OF to €M - 133.5	OF to €M - 133.5	OF to €M - 133.5	W - 145	
	Glass Height			H - 145	OF to €T - 133.5	OF to €T - 133.5	€T to €T - 133.5	H - 145	H - 145	OF to €T - 133.5	H - 145	OF to €T - 133.5	H - 145	OF to €T - 133.5	OF to €T - 133.5	OF to €T - 133.5	
Vent (2)	Glass Width					W - 133.5		OF to €M - 133.5				OF to €M - 133.5	€M to €M - 122	€M to €M - 122	OF to €M - 122		
	Glass Height						OF to €T - 133.5	OF to €T - 133.5				OF to €T - 133.5	OF to €T - 133.5	OF to €T - 133.5	OF to €T - 133.5		
Fixed Panel (1)	Glass Width	W - 61	W - 61		W - 61		W - 61	OF to €M - 49.5	OF to €M - 49.5	W - 61	€M to €M - 38	€M to €M - 38	€M to €M - 38	W - 61	OF to €M - 49.5	W - 61	
	Glass Height	H - 61	OF to €T - 49.5		OF to €T - 49.5		OF to €T - 49.5	H - 61	OF to €T - 49.5	OF to €T - 49.5	H - 61	H - 61	OF to €T - 49.5	OF to €T - 49.5	H - 61	OF to €T - 49.5	

LEGEND:

- W = Overall window outer frame width - outside
- H = Overall window outer frame height - outside
- € = Centre line of transom/mullion
- O/F = Extreme edge of outer frame

Sections:

- Outerframe: ETC6105
- Sash: ETC629
- Transom/Mullion: ETC6305
ETC6306

